

OPERATOR'S MANUAL

NPB-70

Handheld Capnograph

MANUEL DE L'UTILISATEUR

NPB-70

Capnograph Portatif

GEBRAUCHSANWEISUNG

NPB-70

Tragbarer Kapnograph

MANUAL DEL OPERADOR

NPB-70

Capnógrafo portátil

MANUAL PER L'UTENTE

NPB-70

Capnografo Palmare

MALLINCKRODT

Caution: U.S. Federal law restricts this device to sale by or on the order of a physician.
To contact Mallinckrodt, Inc. representative: In the United States, call 1-800-635-5267; outside the United States, call your local Mallinckrodt representative.

Mallinckrodt Inc.
675 McDonnell Boulevard
PO. Box 5840
St. Louis, MO 63134
Tel 314.654.2000
Toll Free 1.800.635.5267

Mallinckrodt
Europe BV
Hambakenwetering 1
5231 DD 's-Hertogenbosch
The Netherlands
Tel. +31.73.6485200

Nellcor Puritan Bennett
4280 Hacienda Drive
Pleasanton, CA 94588

**Nellcor Puritan Bennett Inc. is a wholly owned subsidiary of Mallinckrodt, Inc.
Nellcor and Nellcor Puritan Bennett are trademarks of Mallinckrodt Inc.**

**To obtain information about a warranty, if any, for this product, contact
Mallinckrodt Technical Services or your local Mallinckrodt representative.**

***Microstream* and *FilterLine* are trademarks of Oridion Medical Ltd.
Capnography covered by one or more of the following U.S. Patents and foreign
equivalents: 4,755,675; 5,063,275; 5,300,859, 5,657,750.**

OPERATOR'S MANUAL

Handheld Capnograph



Notice: Purchase of this instrument confers no express or implied license under any Oridion Medical patent to use the instrument with any accessory that is not manufactured or licensed by Oridion Medical Ltd.

The following are trademarks of Oridion Medical Ltd.: Microstream and FilterLine.

Capnography covered by one or more of the following U.S. patents and foreign equivalents: 4,755,675; 5,063,275; 5,300,859, 5,657,750.

TABLE OF CONTENTS

Contents	
List of Figures	
List of Tables	

CONTENTS

SAFETY INFORMATION	1
WARNINGS	1
General	1
MRI Scanning	2
Alarms.....	2
Fire Hazard	3
Electrical	3
Electro Magnetic Interference.....	4
SYMBOLS.....	4
INTRODUCTION	7
MONITOR FEATURES	7
OVERVIEW	9
PRINCIPLES OF OPERATION	9
Microstream EtCO ₂ Circuits.....	10
DISPLAYS, CONTROLS, AND CONNECTORS	12
INITIAL SETUP	15
POWER REQUIREMENTS	15
Battery and Power Usage.....	16
Battery Pack.....	16
UNPACKING AND INSPECTION	18
Components	18
Optional Accessories	19
START-UP AND SELF-TEST	20
Preparation	20
Initialization	21
MEASURING MODE.....	22
HANDHELD CAPNOGRAPH QUICK GUIDE.....	23
CIRCUITS	25
MICROSTREAM EtCO ₂ CIRCUITS.....	25
Basic Principles.....	25

BASIC OPERATION	27
DATA DISPLAY SCREENS.....	27
CO ₂ Waveform	28
CO ₂ Trends	28
Meter Mode.....	29
Graphic Display Screen Contrast.....	29
DISPLAYED DATA OPTIONS	30
ALARM FUNCTIONS.....	31
Alarms.....	31
ALARM LIMITS MENU	33
Alarm Silence.....	34
ALARM SILENCE/STANDBY MENU.....	35
INSTRUMENT SETTINGS MENU.....	36
Instrument Settings Menu Parameters	36
User-defined Parameters.....	37
Changing Instrument Settings	38
Institutional Settings.....	39
STANDBY	39
COMMUNICATION INTERFACE	41
COMMUNICATION ADAPTER.....	41
COMMUNICATION OPTIONS TO A PRINTER AND PC.....	42
Screen.....	42
Tabular Trend (5s)/(1m)	43
Graphic Trend.....	44
Trend History	45
Tabular Trend (14 Hr)	47
Monitor Setup for Printer/PC Communication.....	48
COMMUNICATION INTERFACE TO A PRINTER	49
Printer Setup.....	49
PRINTING.....	52
COMMUNICATION INTERFACE TO A PC	53
Transferring the Data to the PC.....	53
Downloading the Data.....	53
TROUBLESHOOTING.....	54
ADDITIONAL INFORMATION	55
Ordering the Seiko DPU-414 Printer	55
Technical Support for the Monitor.....	55
Technical Support for the Seiko Printer.....	55

TROUBLESHOOTING.....	57
ALARMS AND MESSAGES.....	57
Alarm and Message Priorities.....	57
Warnings.....	57
Cautions.....	59
Advisory Messages.....	60
Silent Advisories.....	61
TROUBLESHOOTING GUIDE.....	63
MAINTENANCE.....	65
PERIODIC MAINTENANCE.....	65
SERVICE.....	66
CLEANING.....	66
CO ₂ CALIBRATION CHECK.....	66
RETURNING THE MONITOR.....	69
TECHNICAL ASSISTANCE.....	69
SPECIFICATIONS.....	71
PHYSICAL.....	71
Size.....	71
Weight (including battery pack).....	71
Noise Emission.....	71
ENVIRONMENTAL.....	71
Temperature.....	71
Relative Humidity.....	71
Pressure and Altitude (for operating and storage).....	71
SAFETY STANDARDS.....	72
PERFORMANCE.....	72
POWER SPECIFICATIONS.....	73
External Power Source.....	73
Internal Power Source.....	73
COMPONENTS AND USER INTERFACE.....	73
Displays.....	73
Controls and Indicators.....	74
Connections.....	74

List of Figures

Figure 1: Monitor Front and Side View.....	12
Figure 2: Monitor Rear View.....	13
Figure 3: Initialization Screen.....	21
Figure 4: Quick Guide Adhesive Label.....	23
Figure 5: Monitor Display Screen and LEDs.....	27
Figure 6: Tabular Trend Printout.....	43
Figure 7: Graphic Trend Printout.....	44
Figure 8: Trend History Printout.....	46

List of Tables

Table 1: Packaged monitor.....	18
Table 2: Display Screens.....	30
Table 3: Factory Default Alarm Range Values.....	32
Table 4: Alarm Limits.....	33
Table 5: Alarm Silence/Standby.....	35
Table 6: Instrument Settings Menu Parameters.....	36
Table 7: Changing Instrument Settings.....	38
Table 8: Institutional Settings.....	39
Table 9: Print Options.....	42
Table 10: Monitor Setup.....	48
Table 11: Dip Switch Settings.....	50
Table 12: Start/Stop Printing Options.....	52
Table 13: COM Property Settings.....	53
Table 14: Troubleshooting Examples.....	54
Table 15: Warning Messages.....	58
Table 16: Caution Messages.....	59
Table 17: Advisory Messages.....	60
Table 18: Silent Advisory Messages.....	61
Table 19: Troubleshooting Guide.....	63
Table 20: Accessing the Service Mode.....	65
Table 21: CO ₂ Calibration Check.....	67

SAFETY INFORMATION

Warnings
Symbols

To use the monitor correctly and safely, carefully read this operator's manual and the *Directions for Use* for the Microstream EtCO₂ circuits. Use of the monitor requires full understanding and strict observation of these instructions, precautionary information in boldface type, and specifications.

WARNINGS

General

WARNING: If uncertain about the accuracy of any measurement, check the patient's vital signs by alternate means, then make sure the monitor is functioning correctly.

WARNING: To ensure patient safety, do not place the monitor in any position that might cause it to fall on the patient.

WARNING: Carefully route patient cabling (FilterLine) to reduce the possibility of patient entanglement or strangulation.

WARNING: Do not lift the monitor by the FilterLine as it could disconnect from the monitor, causing the monitor to fall on the patient.

WARNING: To ensure accurate performance and prevent device failure, do not expose the monitor to extreme moisture, such as rain.

WARNING: CO₂ readings and respiratory rate readings can be affected by certain ambient environmental conditions and certain patient conditions.

Caution: The monitor is a prescription device and to be operated by qualified healthcare personnel only.

Caution: Connect the gas outlet to a scavenging system when using the monitor with N₂O or other anesthetic agents.

MRI Scanning

WARNING: Do not use the monitor during magnetic resonance imaging (MRI) scanning.

Alarms

WARNING: Do not silence the audible alarm if patient safety may be compromised.

WARNING: Always respond immediately to a system alarm since the patient may not be monitored during certain alarm conditions.

WARNING: Before each use, verify that the alarm limits are appropriate for the patient being monitored.

WARNING: Check the audible alarm silence duration before temporarily silencing the audible alarms.

WARNING: The monitor is not to be used as an apnea monitor. (An apnea message appears if a valid breath has not been detected for 15 seconds [neonatal mode] or 30 seconds [adult mode]. This indicates the time elapsed since the last valid breath and is not a diagnosis.)

Fire Hazard

WARNING: When using the monitor with flammable gases or anesthetics, such as high concentrations of oxygen or nitrous oxide, connect the gas outlet to a scavenger system.

Electrical

WARNING: Electric shock hazard. The monitor's cover is to be removed only by qualified service personnel. There are no user-serviceable parts inside.

WARNING: To ensure patient electrical isolation, connect only to other equipment with circuits that are electrically isolated.

WARNING: Use only the medical-grade AC adapter provided by the manufacturer. If in doubt about the integrity of the mains supply connection, operate the monitor from its internal battery pack.

WARNING: Do not connect to a printer or to a PC unless using the Communication Adapter provided by the manufacturer as an optional accessory. The Printer and PC (when connected to the patient through the Communication Adapter) must be distanced from the patient environment by at least 1.5 m.

Electro Magnetic Interference

WARNING: This device has been tested and found to comply with the requirements for medical devices according to the standard EN60601-1/1990, A1/1993, A2/1995. These standards are designed to provide reasonable protection against harmful interference in a typical medical installation. However, because of the proliferation of radio-frequency transmitting equipment and other sources of electrical noise in the healthcare environments (for example, cellular phones, mobile two-way radios, electrical appliances), it is possible that high levels of such interference due to close proximity or strength of a source, may result in disruption of performance of this device.

SYMBOLS

The following symbols appear on the monitor and accessories:



See Instructions for Use



Gas Outlet



Defibrillator-proof type Type BF equipment
(patient electrically isolated)



Audio Alarms Off



Plug Icon



Battery Icon



Breaths per minute



End tidal carbon dioxide value

The following symbols appear on the Communication Adapter:



Serial communications port



DC output



DC input



Printer interface



PC interface





Discount

CARDIO

www.discount.com

INTRODUCTION

Monitor Features

This manual provides directions for setup and operation of the handheld capnograph monitor.

The device is a handheld capnograph that continuously monitors end tidal carbon dioxide (EtCO₂) and respiratory rate. The monitor is for attended monitoring only and must be used in the continuous presence of a qualified healthcare provider. It is intended for use in any environment where continuous, noninvasive monitoring of these parameters is desired, including hospital and mobile use (when protected from excessive moisture such as direct rainfall).

The monitor is intended for use on adult, pediatric, and infant/neonatal patients.

MONITOR FEATURES

- Capnograph in a small, handheld, lightweight monitor.
- Measures and displays EtCO₂, and respiration rate, in one graphic and two digital displays.
- Displays CO₂ waveforms and trends.
- Utilizes a wide range of Microstream EtCO₂ circuits and adapters for all applications.
- Operates on main line power or a rechargeable Nickel Metal Hydride battery pack.
- Employs audible and visual alarm warnings for monitored parameters and instrument malfunctions.
- Provides user selectable language options: English, French, German, Spanish.
- Displays EtCO₂ values in mmHg, kPa or Vol%.
- Provides output for printer or PC.



OVERVIEW

Principles of Operation
Displays, Controls, and Connectors

The monitor incorporates Oridion's Microstream capnography technology.

PRINCIPLES OF OPERATION

The monitor uses Microstream non-dispersive infrared (IR) spectroscopy to continuously measure the amount of CO₂ during every breath, the amounts of CO₂ present at the end of exhalation (EtCO₂) and during inhalation (FiCO₂), and the Respiratory Rate.

Infrared spectroscopy is used to measure the concentration of molecules that absorb infrared light. Because the absorption is proportional to the concentration of the absorbing molecule, the concentration can be determined by comparing its absorption to that of a known standard.

The Microstream EtCO₂ circuits deliver a sample of the inhaled and exhaled gases from the ventilator circuit or directly from the patient into the monitor for CO₂ measurement. Moisture and patient secretions are extracted from the sample while maintaining the shape of the CO₂ waveform.

The 50 ml/min. low sampling flow rate reduces liquid and secretion accumulation, thus the sample flow is not obstructed, even in humid ICU environments.

Once inside the Microstream CO₂ sensor, the gas sample goes through a microsample cell (15 microliters). This extremely small volume is quickly flushed, allowing for fast rise time and accurate CO₂ readings, even at high respiration rates.

The Microbeam IR source illuminates the microsample cell and the reference channel. This proprietary IR light source generates only the specific wavelengths characteristic of the CO₂ absorption spectrum. Therefore, no compensations are required when different

concentrations of N_2O , O_2 , anesthetic agents, and water vapor are present in the inhaled and exhaled breath. The radiation that passes through the microsample cell and the radiation that passes through the reference channel are measured by the IR detectors.

The microcomputer in the monitor calculates the CO_2 concentration by comparing the signals from both channels.

Microstream Et CO_2 Circuits

— *Microstream FilterLine*

The Microstream FilterLine has four active elements that work together to offer a solution to the problems that have previously posed challenges to capnography in ICU, emergency, and transport applications. These elements are described below.

* *Hydrophobic filter*

The hydrophobic filter is located at the end of the sample line that is closest to the capnograph. This filter strips the remaining water vapor from the gas sample while keeping a laminar flow of the gas. This laminar flow minimizes distortion of the CO_2 waveform.

This filter is made of 0.45μ hydrophobic porous media that reduces biological contaminants.

* *Drying element*

The drying element is a tube made of a synthetic material that is chemically stable and has high water absorption. This material allows the water vapor to pass outside the tube, thereby adjusting the humidity inside the FilterLine close to the level of humidity in the ambient air.

* *Sample line*

The sample line has low dead space due to its small internal diameter. This provides a sharp waveform and an accurate CO₂ reading at high breath rate per minute. The sample line is not affected by gases and anesthetic agents in the operating room environment.

* *FilterLine Recognition Safeguard*

When the FilterLine is attached to the monitor, the FilterLine Recognition Safeguard (FRS) identifies the FilterLine and activates the monitor, thus enabling it to take a measurement.

— *Microstream Airway Adapter*

The Microstream airway adapter design provides multiple channels for the sampled air from the airway minimizing the possibility of water infiltration or line blockage. These multiple channels allow uninterrupted monitoring for all adapter orientations and in all applications. The Microstream airway adapter provides optimal performance in all directions and is seldom disabled by secretions or liquids.

DISPLAYS, CONTROLS, AND CONNECTORS

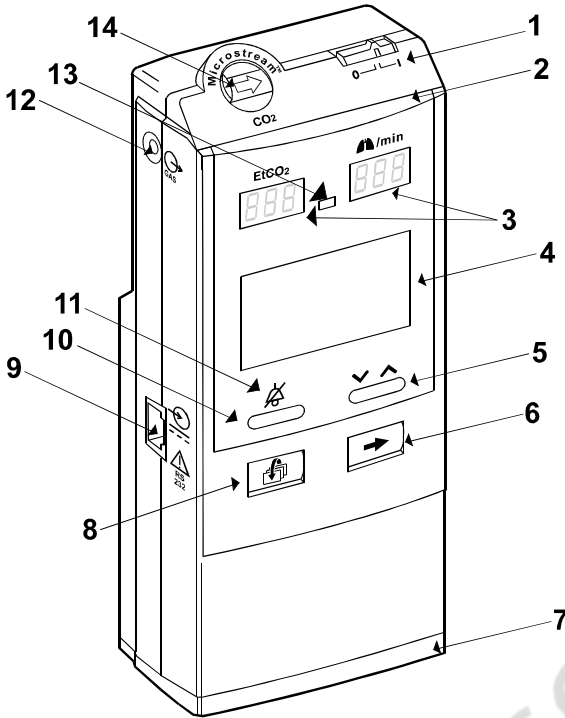

Figure 1: Monitor Front and Side View

The numbered labels in Figure 1 are described below.

- | | |
|--|---|
| 1. ON/OFF Switch | *8. Event/Home Button |
| 2. Alarm Bar | 9. Power Supply/ Communication Adapter Port |
| 3. Digital Display of EtCO ₂ and Respiration Rate | 10. Alarm Silence/Alarm Silence Menu Button |
| 4. Graphic Display | 11. Alarm Silence Indicator |
| 5. Contrast/Changes Value Button | 12. Gas Outlet |
| *6. Next/Menu Button | 13. Photo Resistor |
| 7. Battery Pack | 14. FilterLine Input Connector |

*6+8 = Data Transfer ON/OFF

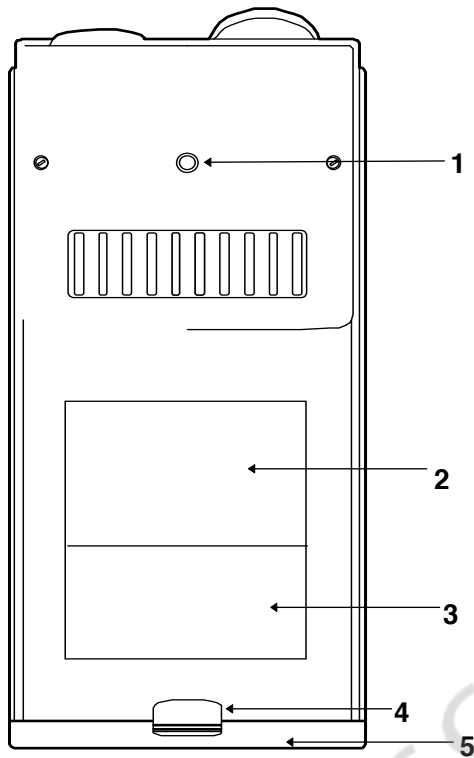

Figure 2: Monitor Rear View

The numbered labels in Figure 2 are described below.

- | | |
|---|--------------------------------|
| 1. Clamp Adapter | 3. Serial Number Label |
| 2. Space for Quick Guide Adhesive Label | 4. Battery Pack Release Button |
| | 5. Battery Pack |



INITIAL SETUP

Power Requirements
Unpacking & Inspection
Start-up and Self-Test
Measuring Mode
Handheld Capnograph Quick Guide

POWER REQUIREMENTS

The monitor operates on batteries or on AC power. It is equipped with a rechargeable Nickel Metal Hydride battery pack. When a power outlet is available, use the medical grade AC adapter provided with the monitor.

Before using the monitor in the field, ensure that the battery pack is fully charged. (At the measuring mode, check that the battery icon at the right side of the graphic display is full.)

Note: If the battery is not fully charged, the icon may first show as full and after a short period of time will drop to indicate the real charge level.

A fully charged battery pack provides between three to six operating hours, depending on power management (refer to Table 6 for a description of the power management options).

WARNING: Use only the medical-grade AC adapter provided by the manufacturer. If in doubt about the integrity of the mains supply connection, operate the monitor from its internal battery pack.

WARNING: To ensure patient electrical isolation, connect only to other equipment with circuits that are electrically isolated.

Battery and Power Usage

If power is lost when the monitor is operating from AC power, the monitor automatically switches to its internal battery pack for power.

A plug-shaped icon  at the bottom right side of the graphic display is displayed when the monitor operates from an external power source and the battery pack is fully charged. A battery-shaped icon

 is displayed when the monitor operates from the battery pack. The battery icon will show the battery pack's approximate charge level.

An advisory message, **Battery** ↓ ↓ !, appears when approximately 40 minutes of battery charge remains. A caution message **Battery** ↓ ↓ !! appears when approximately 15 minutes of charge time remains.

While the monitor is connected to AC power, the battery pack can be replaced without interrupting monitoring.

Battery Pack

Before using the monitor for the first time, it is recommended to charge and discharge the battery 3 times to ensure full battery capacity.

Internal Recharge Function

Caution: Do not attempt to disassemble the battery pack. It is a sealed unit and has no serviceable parts inside.

When the monitor is connected to an external power source (even if the monitor is in the “OFF” position), the battery pack charges automatically. During charging, if the instrument is on, the battery-shaped icon displays a filling pattern. It takes approximately 4.5 hours to fully charge an empty battery pack. Additional battery packs can be purchased from your local distributor.

The recommended temperature for battery charging is between 5°C to 45°C.

Important! The following information relates to the safe handling, storage, and disposal of the monitor battery pack.

Battery Testing

The battery pack charge level should be tested before each use by observing the level on the battery icon after self-test. For a correct reading, wait for the battery charge level to stabilize. It is recommended to replace or recharge the battery pack when the advisory message **Battery ↓ !** appears on the graphic display screen (refer to the *Troubleshooting* section).

Handling

- Do not immerse the battery pack in water; it may malfunction.
- Only recharge the battery pack in the monitor or use a charger provided by your local distributor to avoid possible heating, burning or rupture of the battery pack.

Storage

- Short-term storage (one month or less): The battery pack has an automatic discharge feature. You must periodically check the charge level of the battery pack.
- Long-term storage (6 months or more): The battery pack must be stored in a cold, dry area. Its charge decreases over time. To restore the battery pack to full power, charge and discharge it three times before use. Long-term storage without charging the battery, may degrade the battery capacity.

Disposal

- Do not dispose of the battery pack in a fire; it may explode.
- Be sure to follow local governing ordinances and recycling instructions regarding disposal or recycling of batteries.

UNPACKING AND INSPECTION

Components

1. Remove the monitor and the circuits from the box carefully.
2. Check that the following items are included (Table 1):

Table 1: Packaged monitor

Contents of Package	Qty
Handheld Capnograph Monitor	1
Microstream EtCO ₂ Circuit Kit	1 kit
AC Adapter	1
AC Adapter Power Cable	1
Operator's Manual	1
Quick Guide Adhesive Label	1

3. Inspect each component. If the package is damaged or any component is missing, contact your local representative.

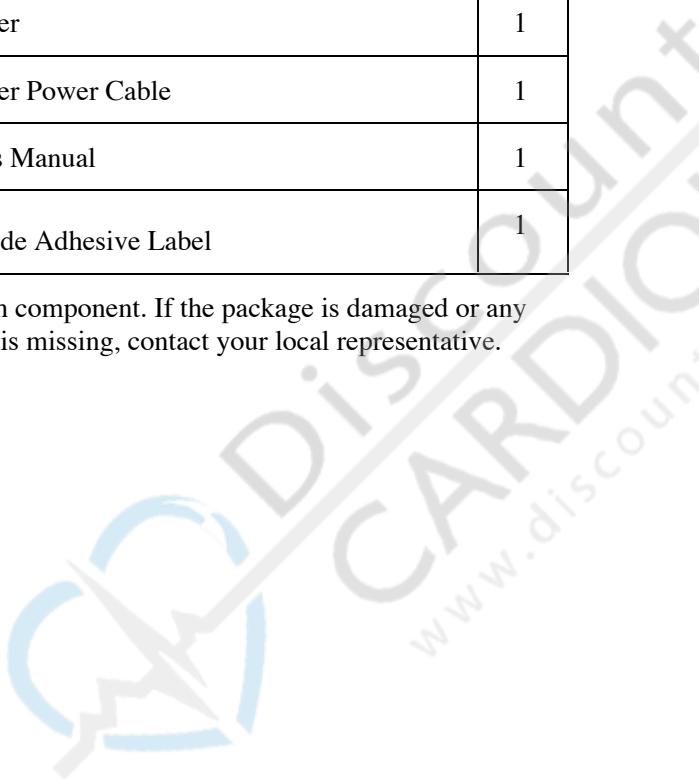

Optional Accessories

The following items are available from your local distributor for use with the monitor:

- Carrying Case
- Clamp
- Rechargeable Battery Pack
- External Battery Charger
- Battery Pack Carrying Pouch
- Communication Adapter Kit (for interface to PC or printer)
- Calibration Gas Kit
- Service Manual

Important! To protect the unit, the manufacturer recommends using either the carrying case or the clamp, depending on the type of application.

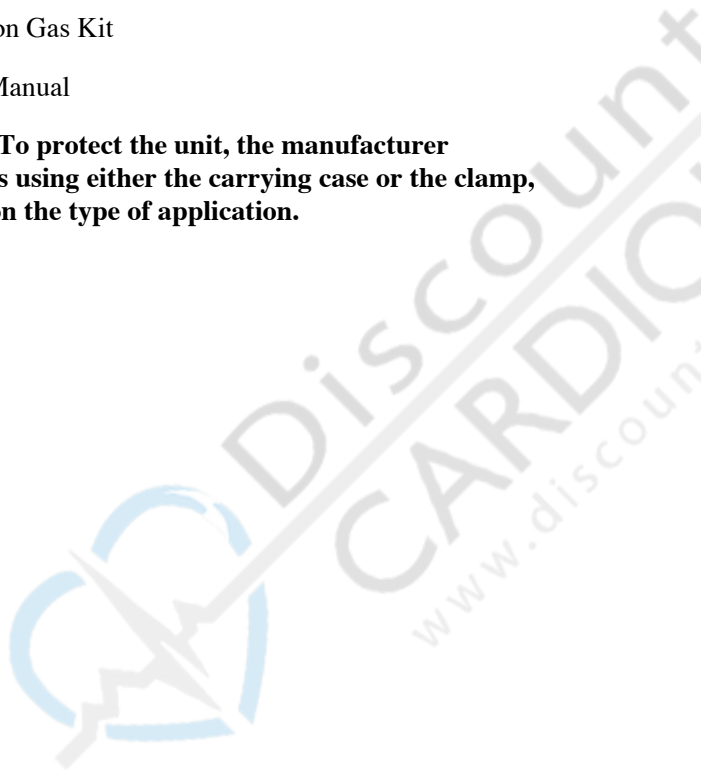

START-UP AND SELF-TEST

WARNING: Do not lift the monitor by the FilterLine as it could disconnect from the monitor causing it to drop on the patient.

WARNING: To ensure patient safety, do not place the monitor in any position that might cause it to fall on the patient. As with all medical equipment, carefully route the FilterLine cable to reduce the possibility of patient entanglement or strangulation.

Caution: The monitor is intended only as an adjunct in patient assessment. It must be used in conjunction with clinical signs and symptoms.

Caution: The monitor is a prescription device and is to be operated by qualified healthcare providers only.

Caution: Only use Microstream EtCO₂ circuits to ensure that the monitor functions properly.

Caution: Connect the gas outlet to a scavenging system when using the monitor with N₂O or other anesthetic agents.

Preparation

Prior to start-up:

1. Slide open the input connector's shutter and connect the appropriate Microstream EtCO₂ circuit.
2. Connect the appropriate Microstream EtCO₂ circuit to the patient as described in the Directions for Use.

Note: When the monitor is handheld, it is recommended to use it with its carrying case (available as an optional accessory).

When the monitor is used in stationary applications, it is recommended to secure it with the clamp (available as an optional accessory).

Initialization

Caution: If any monitor response does not seem appropriate, do not use the monitor. Instead, contact your local distributor.

Caution: Immediately after power-up, confirm that all display segments and icons function.

1. Turn on the monitor by sliding the ON/OFF switch to the **ON** position.
2. Verify that the monitor is working properly. Proper working condition is verified by completing the power-on self-test described in the following step.

When turned on, the initialization screen appears, the monitor automatically performs a self-test and the self-test bar fills (for up to 15 seconds). The display and alarm functions are tested activating the LCD, alarm bar, seven segment displays, alarm silence indicator, and buzzer. In this mode all alarms are disabled. (Refer to Figure 3.)



Figure 3: Initialization Screen

During Self-Test, the EtCO₂ and Respiration Rate LED's show dashes. When the monitor is **Ready** and the FilterLine circuit is connected, the dashes in the EtCO₂ and Respiration Rate LED's are replaced by numeric values. If the FilterLine circuit is not connected to the monitor, dashes will appear on the LED's.

MEASURING MODE

In Measuring Mode, the monitor is measuring, displaying, and storing event data, or printing data that has been stored in its memory.

While taking measurements, the monitor displays EtCO₂ and respiration rate readings on the digital displays. The waveform and other information, according to the selected screen; (see the Basic Operation section of this manual) are shown on the graphic display.

The monitor begins measuring EtCO₂ after recognizing one breath (after monitor power-up or after exiting Standby). The monitor recognizes two breath measurement ranges:

Valid breath: values ≥ 7.5 mmHg (for adult mode) or ≥ 5.0 mmHg (for neonatal mode)

Low readings breath: values < 7.5 mmHg (for adult mode) or < 5.0 mmHg (for neonatal mode)

Note: If the first breath the monitor recognizes is a **Low readings breath**, the monitor will not display nor emit warning signals and an **APNEA** message will not appear. If the values go above 7.5 mmHg (for adult mode) or 5.0 mmHg (for neonatal mode), and then fall below these ranges, the monitor will display an **APNEA** message and emit warning signals (see the *Troubleshooting* section of this manual).

EtCO₂ readings between 3.0-7.0 mmHg (adult mode) or 3.0-5.0 mmHg (neonatal mode) appear as numerical values on the EtCO₂ LED's. Readings < 3.0 mmHg show as **0** (zero) on the LED's.

The monitor begins measuring Respiration Rate after two valid breaths.

The waveform appears on the graphic display for all EtCO₂ values.

HANDHELD CAPNOGRAPH QUICK GUIDE

1. Connect only Microstream EtCO₂ circuits to the monitor.
2. **Battery pack operation:** First, switch the monitor **ON**, check that the battery pack is charged (at measuring mode, check that the battery icon at the right side of the graphic display is full).

AC operation: Connect the AC adapter to the monitor and plug the cord into the mains power supply. Switch the monitor **ON**. Check that the battery icon displays a filling pattern or the plug icon shows.

(Refer to Figure 4 for all button functions.)

3. Adjust the parameters in the Alarm Limits menu, Instrument Setup menu, and Alarm Silence menu to the values appropriate to the patient's condition.







Quick Guide		
Power On	Short Press	Long Press
	Changes Displays / Selects Parameters	Accesses Menus
	Event Mark	Home / Erase Trend
	Changes Values / Contrast	Quick Scroll
	Sound ON / OFF	Accesses Alarm Menu
	+ 	Data Transfer ON / OFF

Figure 4: Quick Guide Adhesive Label



CIRCUITS

Microstream EtCO₂ Circuits

MICROSTREAM EtCO₂ CIRCUITS

FilterLines (sampling lines) and Airway Adapters comprise the Microstream EtCO₂ family of circuits for EtCO₂ monitoring.

Basic Principles

Caution: Before use, carefully read the Microstream EtCO₂ Circuits *Directions for Use*.

Caution: Only use Microstream EtCO₂ Circuits to ensure the monitor functions properly.

Caution: Do not reuse, sterilize, or clean Microstream EtCO₂ Circuits as they are designed for single patient use.

Caution: Dispose of Microstream EtCO₂ Circuits according to standard operating procedures or local regulations for the disposal of contaminated medical waste.

When choosing Microstream EtCO₂ Circuits, the following should be considered:

- Patient's breathing situation (intubated or non-intubated)
- Mode of ventilation (if ventilated)
- Duration of use
- Patient's weight

For further information, please contact your local representative.

Select the appropriate Microstream EtCO₂ FilterLine and/or Airway Adapter and connect it to the monitor before attaching it to the patient's airway. Be sure to follow Microstream EtCO₂ Circuits' *Directions for Use* for proper connection.



Discount

CARDIO

www.discount.com

BASIC OPERATION

Data Display Screens
 Displayed Data Options
 Alarm Functions
 Alarm Limits Menu
 Alarm Silence/Standby Menu
 Instrument Settings Menu
 Standby

DATA DISPLAY SCREENS

In Measuring Mode, the monitor constantly measures and displays the CO₂ waveform, EtCO₂, and respiratory rate (bpm) values.

Note: For both neonatal and adult patients, the EtCO₂ displayed on the LED Numeric Displays represents the maximum value during the last 15 seconds (updated every 5 seconds). The EtCO₂ is displayed from the first breath. The EtCO₂ warning is according to the 7-Segment value.

The respiratory rate and EtCO₂ values are constantly shown in the LEDs. Waveform or Trends are shown in the graphic display depending on the selected display screen (see Figure 5 and Table 2). Power icons, advisories, warnings, or cautions appear superimposed over the data display.

At any time during the measuring mode, the user can mark a special event by a short press of  and a short duration tone sounds. The event is stored in the monitor's memory and will appear on the data printout marked by an * on the tabular trend printout and a vertical line on the graphic trend printout.

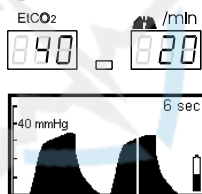

Figure 5: Monitor Display Screen and LEDs

There are four data display screens (Table 2):

- CO₂ Waveform
- CO₂ Trend, 30 minutes
- CO₂ Trend, 8 hours
- Meter Mode

CO₂ Waveform

The CO₂ waveform screen displays a real-time CO₂ waveform, and respiration rates. (The end tidal CO₂ and bpm values are shown simultaneously on the digital displays.)

CO₂ Time Base

The time base is the period of time captured on the display. The time base default values are:

- 6 seconds for Adult Mode
- 3 seconds for Neonatal Mode

During periods of high respiration rates, the display will automatically depict the shorter time base to avoid compression of the waveform.

The time base appears at the top right side of the graphic screen as a Temporary Silent Advisory and is shown for 5 seconds each time the instrument enters the CO₂ waveform screen or after every change of the time base. The instrument also automatically changes the time base.

CO₂ Trends

- The trends graphs represent trend data of the last 30 minutes or 8 hours (15-second or 4-minute resolution respectively). The trends are shown in the CO₂ scale selected by the user. The tabular trend data for 14 hours (5-second resolution) is relevant for the print/PC option only.

During the 14-hour tabular trend period, the data of (up to) the last 100 patients are stored. (A new patient is defined each time the monitor is turned on/off or enters Standby.)

Note: In the case of the “Autoscale Option”, the CO₂ scale is that of the maximum range.

- The FiCO₂ value is shown as light pixels at the bottom of the trends graph.
- When the monitor is turned **ON** a trend data border will mark the end of the previous trend. A trend data border will also appear after exiting Standby and returning to measuring mode. The trend data border is a vertical line on the graph. An event will appear on the tabular trend printout marked by an “*” and as a vertical line on the graphic trend printout.
- When you enter a trend display, a temporary message “Press  To Erase” appears for 3 seconds. This allows you to erase all old trends. This message will not appear during an alarm but the trend erase function will still work.
- The real-time EtCO₂ and respiration rate values are shown on the digital display.

Meter Mode

The Meter Mode screen displays the EtCO₂ value on the left side of the screen and the respiration rate on the right side of the screen.

This mode is recommended in the following cases:

- When the power management is at **Low** (see Table 6).
- When the monitor display is exposed to direct sunlight affecting the digital display reading.







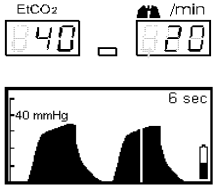

Graphic Display Screen Contrast

The LCD contrast intensity can be adjusted during Measuring Mode. To adjust the contrast, press the contrast button ; press the right side for a darker contrast and the left side for a lighter contrast.

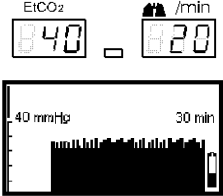
The photo resistor senses the ambient light intensity and accordingly switches the backlight ON or OFF during **Normal** power management setting.

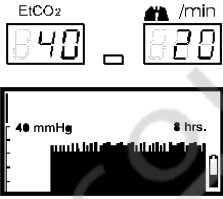
DISPLAYED DATA OPTIONS

Table 2: Display Screens

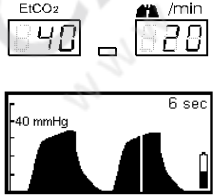
To View	Press	Result
CO ₂ waveform	Appears automatically	
30 min. - CO ₂ Trend	 1 st short press	
8 hr. - CO ₂ Trend	 2 nd short press	
Meter Mode	 3 rd short press	
CO ₂ waveform*	 4 th short press	

* To return to CO₂ waveform (Home) from any screen or menu:
 Long press the  button.

ALARM FUNCTIONS

WARNING: Do not turn off the audible alarm if patient safety could be compromised. Pressing the alarm silence button turns the audio alarms OFF and turns the alarm silence icon LED indicator ON. In this condition there will be no audible alarms in the event of adverse patient conditions.

The monitor has four levels of alarms. For full details on alarms, see the *Troubleshooting* section of this manual.

Alarms

Warnings are the highest level of alarms to alert the user that the patient's condition is beyond predefined limits. Alarms can be set from the *Alarm Limits* menu (see Table 4). The monitor has the following alarms with adjustable level settings:

- EtCO₂ high and low levels
- FiCO₂ high level

Apnea is a message alerting the user when no valid breath is detected after a predetermined time depending on the patient mode: 15 seconds for infant/neonatal patients and 30 seconds for adult patients. The **APNEA** message appears only after warm-up and the monitor measures one valid breath. The apnea alarm stops after the monitor recognizes one valid breath.

The following alarms alert the user of the instrument's status or malfunction:

- Caution messages (audio and visual)
- Advisory messages (audio and visual)
- Silent advisory messages (visual)

Factory Default Alarm Range Values

Table 3 lists the default values of the various alarm ranges. These values can be changed from the *Alarm Limits* menu.

Caution: The monitor will revert to its default alarm limit settings at power on, power interruption, and when changing the patient mode.

Note: The user can have the factory default values of the alarm range permanently changed (see *Institutional Settings*). For further information, call your local distributor.

The CO₂ values in the table are shown in mmHg. The values in parentheses correspond to the kPa and Vol% (at sea level).

Table 3: Factory Default Alarm Range Values

Parameter	Adult Default	Neonate Default	Maximum	Minimum
EtCO ₂ high	50 [6.7]	50 [6.7]	100 [13.0]	5 [0.5]
EtCO ₂ low	15 [2.0]	15 [2.0]	99 [12.9]	0 [0.0]
FiCO ₂ high	8 [1.1]	8 [1.1]	99 [12.9]	2 [0.1]

See the *Instrument Settings Menu* section for a list of parameters that are set by the user and stored in the memory.

CO₂ Scale Options

- 0-50 mmHg (0-7 kPa or Vol%)
- 0-99 mmHg (0-14 kPa or Vol%)
- Autoscale

- Changes from lower to higher scale after 12 consecutive breaths with EtCO₂ values larger than low level scale limit.

- Changes from higher to lower scale after 12 consecutive breaths with EtCO₂ values smaller than low level scale limit.





Whenever autoscale is selected, the trend scale (and printed graphic scale) will be the high-level scale limit.

The Factory Default CO₂ is 0-50 mmHg. The CO₂ scale option will not return to the Factory Default after being changed by the user. See *User-defined Parameters*.

ALARM LIMITS MENU

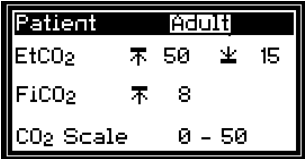
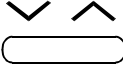
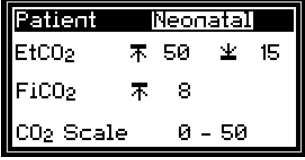
Table 4 explains how to access the Alarm Limits menu and to change the parameters and values.

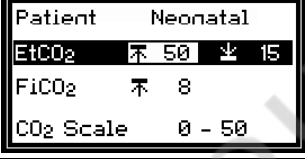
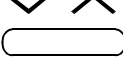
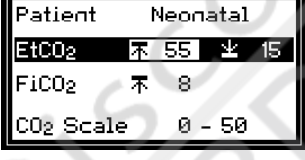
Table 4: Alarm Limits

Objective	Action	Result
To access the <i>Alarm Limits</i> menu from any measuring display*	 long press	
To change the patient mode**	 short press	
To access any displayed parameter	 short press	
To change the parameter's value	 short press/long press***	
To exit and return to Measuring Mode (at any point in the <i>Alarm Limits</i> menu)	 long press	

* If after 15 seconds no action is taken, the display returns to measuring mode.

** The neonatal mode is recommended when a patient's breath rate is >50 breaths per minute. Neonates often have a respiration rate >50 breaths per minute.

*** Long press: the value skips by multiples of 5 (except for FiCO₂).

WARNING: Make sure the patient type and CO₂ scale are appropriate for each patient. An error in the patient type can cause incorrect alarm limits or incorrect CO₂ readings. If the CO₂ scale is not appropriate the waveform will be either incomplete or small.

Alarm Silence

Alarms can be temporarily silenced. A short press of the alarm silence button  will temporarily disable the audible alarm for a pre-set period of time and the alarm silence indicator will be lit. The audible alarm can be reactivated with a short press of the alarm silence button. The default setting is 2 minutes. You can change this setting from the *Alarm Silence/Standby* menu (Table 5).

From the Alarm Silence menu, you can choose to permanently disable a specific audio alarm or all audio alarms.

Whenever an alarm is disabled indefinitely, the alarm silence indicator  will be lit on the front panel and the *Alarm Silence* icon will appear on the right side of the graphic display with the appropriate label.

- **ALL**

All the alarms are turned off.







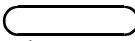

- **CO₂**

CO₂ alarms (including apnea message) are turned off.

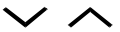
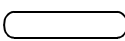
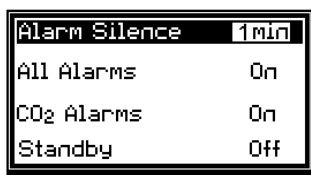
Note: When any alarm is disabled, a single caution burst can sound once every three minutes if opted through Institutional Settings (refer to *Institutional Settings* in this chapter). If an alarm condition occurs when any corresponding alarm is disabled, a message is generated on the monitor display.

ALARM SILENCE/STANDBY MENU

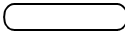
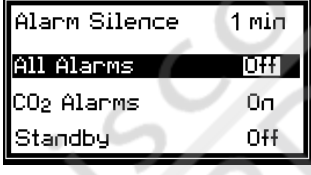
Table 5: Alarm Silence/Standby

Objective	Action	Result
To access the <i>Alarm Silence/Standby</i> menu from any measuring display*.	  long press	 Alarm Silence 2 min All Alarms On CO ₂ Alarms On Standby Off
To change the silence period**.	  short press	 Alarm Silence 1 min All Alarms On CO ₂ Alarms On Standby Off
To access any displayed parameters.	 short press	 Alarm Silence 1 min All Alarms On CO ₂ Alarms On Standby Off
To change the setting of the selected parameter.	  short press	 Alarm Silence 1 min All Alarms Off CO ₂ Alarms On Standby Off
To exit and return to measuring display (at any point in the <i>Alarm Silence/Standby</i> menu).	 long press	 40 mmHg ALL

* If after 15 seconds no action is taken, the display returns to measuring mode.

** Alarm silence limits are from 1-2 minutes.

INSTRUMENT SETTINGS MENU

Instrument Settings Menu Parameters

Table 6 explains the user-defined parameters that can be set from the *Instrument Settings* menu.

Table 6: Instrument Settings Menu Parameters

Parameter	User options
CO ₂ units	mmHg, Vol%, kPa
Power Mgmt (Management)	<p>Full - Display backlight on and 7 segment LEDs at high intensity.</p> <p>Normal - Display backlight on and 7 LEDs segments at normal intensity.</p> <p>Low - Backlight and 7 LEDs segment off.</p> <p>Note: During AC power, the monitor backlight is on all the time but the power management mode setting will continue to display the current selection; full, normal or low.</p>
Print	<p>Screen – the current display is printed</p> <p>Graphic Trend – real time trend is printed in a graphic form.</p> <p>Trend History – stored trend is printed in graphic and tabular form.</p> <p>Tab. Trend (5s) Real time trend data is printed in tabular form (every 5 seconds).</p> <p>Tab. Trend (1m) Real time trend data is printed in tabular form (every minute).</p> <p>Tab. Trend (14h) – with a resolution of 5 seconds. Stored trend is communicated in tabular form.</p>
Language	English, French, German, Spanish
Check Cal.	See the Maintenance section, “CO ₂ Calibration Check.” (Table 21).

User-defined Parameters

The following parameters will not return to their defaults after being changed by the user. These parameters are stored in the memory of the monitor until the next time they are changed by the user.

Note: When changing any parameter below, wait approximately 10 seconds before turning the monitor off. If you turn off the monitor immediately after changing the parameter, the new setting may not be saved.



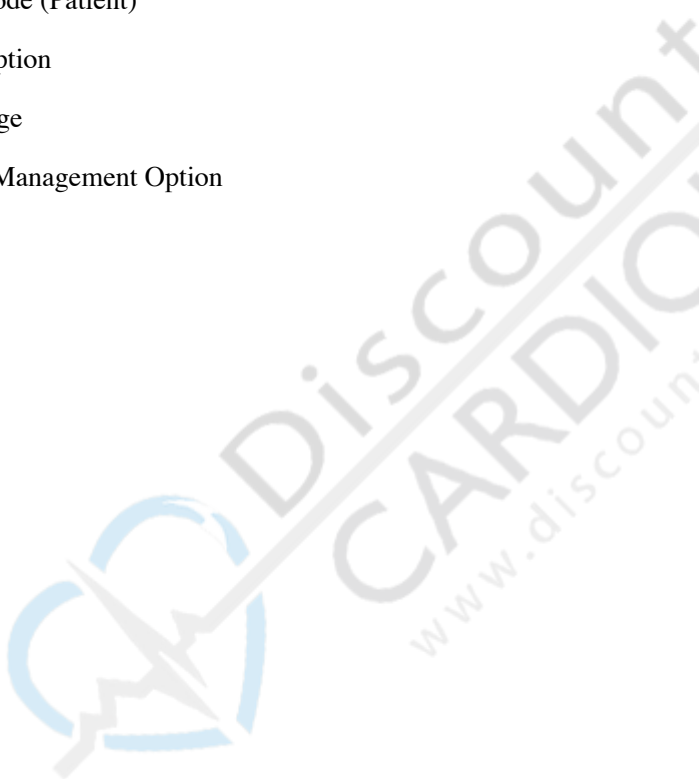



- CO₂ Waveform Scale
- CO₂ Waveform Units
- CO₂ Mode (Patient)
- Print Option
- Language
- Power Management Option

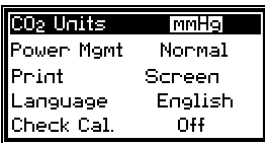
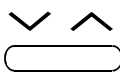
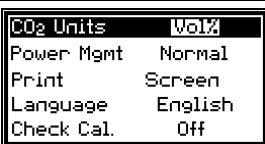

Changing Instrument Settings

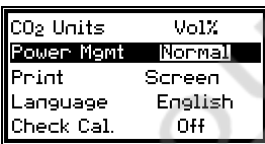
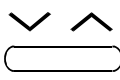
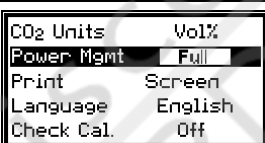
Use this menu (Table 7) to change the instrument settings.

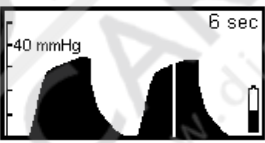
Table 7: Changing Instrument Settings

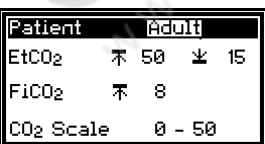
Objective	Action	Result
To access the <i>Instrument Settings</i> menu (first access the <i>Alarm Limits</i> menu from any measuring display by one long press and then the Instrument Settings with the 2 nd long press)*.	 long press (x2)	
To change the CO ₂ scale option.	 short press	
To access any displayed parameter.	 short press	
To change the parameter's setting.	 short press	
Exit and return to the Measuring Mode at any point in the <i>Instrument Settings</i> menu.	 long press	
Exit and return to the <i>Alarm Limits</i> menu.	 long press	

* If after 15 seconds no action is taken, the display returns to measuring mode.

Institutional Settings

The factory default parameter settings in Table 8 can be changed by the manufacturer's service representative or by referring to the Handheld Capnograph Service Manual.

Table 8: Institutional Settings

Parameter	Factory Default Setting
Alarm Default Settings	See <i>Table 3: Default Alarm Range Values</i>
3 Min Alert (to remind user that alarms are set to off)	OFF
BTPS (body temperature, pressure, saturation <i>assumed 37°C, 47mmHg</i>)*	ON

* Calculations are made according to:

$$P_{CO_2} = F_{CO_2} \times (P_b - 47)$$

Where F_{CO_2} is the Fractional concentration of CO_2 in dry gas,

Where $F_{CO_2} = \% CO_2 / 100$

P_b = the ambient pressure

P_{CO_2} = the partial pressure of CO_2 at BTPS

STANDBY

The Standby mode is an automatic or selectable function designed to reduce power consumption and to avoid unnecessary alarms.

To set the monitor manually in the Standby mode, choose the Standby **ON** option from the *Alarm Silence/Standby* menu (Table 5). The Standby screen appears. A long press of any key restores the Measuring Mode. (The *Alarm Limits* menu appears briefly before the Measuring Mode but the alarms cannot be changed at this time).

The monitor will automatically enter Standby mode if, after Power ON, no signal is registered for 10 minutes.

Note: When exiting Standby mode, the monitor reverts to the Factory default of "All Alarms On".

Note: The *Alarm Limits* settings are not changed (do not revert to defaults) when moving to and from Standby mode.



COMMUNICATION INTERFACE

Communication Adapter
Communication Options to a Printer and PC
Communication Interface to a Printer
Communication Interface to a PC
Troubleshooting
Additional Information

The Handheld Capnograph (monitor) can be interfaced to a Seiko DPU-414 printer or to a personal computer (PC) to download real time and trend values for EtCO₂, FiCO₂, and Respiratory Rate. The monitor interfaces to the PC or Printer with the Communication Adapter Kit (available as an optional accessory).

WARNING: When connecting the monitor to another instrument, verify its proper operation before clinical use. Refer to the other device's manual for full instructions. For further questions, contact your local distributor.

WARNING: Do not connect the monitor to a printer or to a PC unless using the Communication Adapter Kit provided by the manufacturer as an optional accessory.

WARNING: When using the printer/PC with main line power, it is recommended to use a medical grade power supply complying with the following standards: EN60601-1, UL 2601-1, CSA C22.2 No. 601.1-M90. If the power supply is not medical grade, the printer/PC must be placed at least 1.5 meters from the patient environment complying with standard EN60601-1-1.

COMMUNICATION ADAPTER

The monitor has a single input/output port. During normal operating conditions, this port is used to connect the monitor to the external medical grade AC adapter. When printing functions or communication to the PC are required, the port is connected to the Communication Adapter. The Communication Adapter uses the port as an input port to connect the monitor to the AC power supply

and/or as an output port to connect the monitor to a printer or PC. For further information, refer to the Communication Adapter Kit *Directions for Use*.

COMMUNICATION OPTIONS TO A PRINTER AND PC

Table 9 lists and describes the options available to download information from the monitor to either a printer and/or PC.

Table 9: Print Options

Option	Description	Output
Screen	The measuring mode displayed on the screen is printed in graphic form.	To printer
Real Time Graphic Trend	The real time trend data is printed in graphic form.	To printer and PC*
Tabular Trend History	The stored trend data is printed in graphic and tabular form.	To printer
Tab. Trend (5s)	The real time trend data is printed in tabular form every 5 seconds.	To printer and PC
Tab. Trend (1m)	The real time trend data is printed in tabular form every minute.	To printer and PC
Tab. Trend (14 Hr)	The stored trend data for the last 14 hours is printed in tabular form.	To printer** and PC

* When downloading to a PC, the graphic will appear as garbled data.

** It is not recommended to download 14 hour trend history to a printer due to the large volume of data and the amount of paper that would be required.

Screen

The Screen option prints the current data display screen (Wave form, CO₂ Trend-30 minutes, CO₂ Trend - 8 hours, and Meter Mode).

Tabular Trend (5s)/(1m)

The Tabular Trend prints EtCO₂, FiCO₂, and Respiration Rate in either 1 minute or 5 second resolutions, depending on the print option selected. After turning the unit off, the printed time is reset to zero.

The printout includes the following data (refer to Figure 6: Tabular Trend Printout):

- Patient data
- Alarms: Only warning messages print (Apnea, EtCO₂ high, EtCO₂ low, FiCO₂ high). If two or more alarms occur simultaneously, only the alarm with the highest priority will appear on the printout (refer to the Handheld Capnograph's Operator's Manual for alarm priorities).
- Events are marked with an asterisk "*" beside the time.
- The CO₂ units print according to the units selected in the Instrument Settings menu and are indicated in the header of the table as: M = mmHg, K = kPa, V = Vol%.

Real Time Tabular Trend

Patient Name: _____ Patient Data
 Date: _____
 Time: _____

CO₂ - units Start Time 00:00

Time	EtCO ₂ M	FiCO ₂ M	RR
00:00:00	38	2	17
00:00:05	38	2	18
00:00:10	38	2	19
00:00:15	38	2	19
00:00:20	38	2	18
00:00:25	38	2	17
00:00:30	38	2	16
00:00:35	38	2	16
00:00:40	37	2	15
00:00:45	37	3	15
*00:00:50	37	3	15
00:00:55	37	3	15
00:01:00	37	3	15
00:01:05	37	3	15
00:01:10	0	0	0
00:01:15	0	0	0
00:01:20	35	0	0
00:01:25	35	2	15
00:01:30	35	2	17
00:01:35	35	2	21

Real Time Tabular Trend

Patient Name: _____ Patient Data
 Date: _____
 Time: _____

CO₂ - units Start Time 00:00

Time	EtCO ₂ M	FiCO ₂ M	RR
00:00:00	39	3	23
00:00:05	39	4	25
00:00:10	39	3	14
00:00:15	35	2	12

Figure 6: Tabular Trend Printout

Graphic Trend

The Graphic Trend data prints in graphic form EtCO₂, FiCO₂, and Respiration Rate values.

The printout includes the following data (refer to Figure 7: Graphic Trend Printout):

- Patient data prints every 2 minutes
- Alarms: Only warning messages (Apnea, EtCO₂ high, EtCO₂ low, FiCO₂ high) print after each graph (after 5 hours). If two or more alarms occur simultaneously, only the alarm with the highest priority will appear on the printout (refer to the Handheld Capnograph's Operator's Manual for alarm priorities).
- Time grid is drawn every 10 minutes
- Time label prints every 30 minutes
- FiCO₂ values appear as white marks at the bottom of the CO₂ graph.
- Events are marked with a horizontal line beside the time.

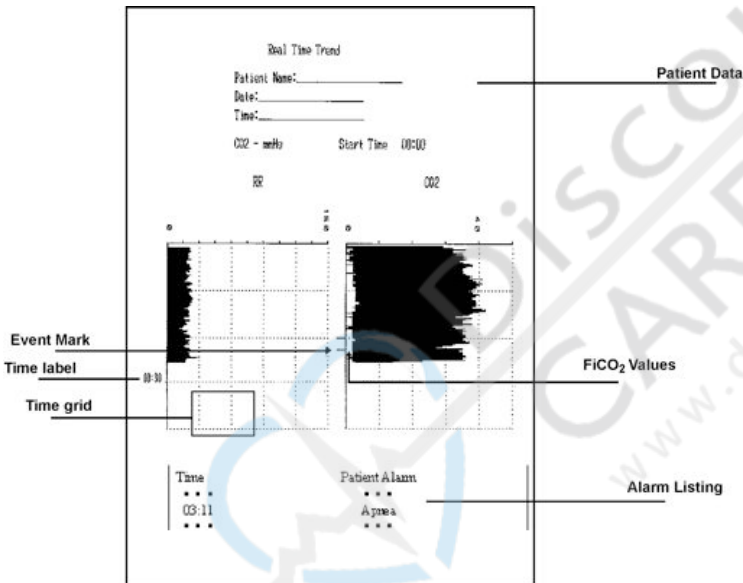

Figure 7: Graphic Trend Printout

Trend History

The Trend History option prints in tabular form the current trend history of EtCO₂, FiCO₂, and Respiratory Rate values. It is printed out in 30-minute and 8-hour scales. The CO₂ units print according to the units selected in the Instrument Settings menu.

Trend information is stored for 8 hours with a 4-minute resolution and 30 minutes with a 15-second resolution.

The printout includes the following information in the order listed below (refer to Figure 8: Trend History Printout):

- Printout header
- 30-minute graphic trend
- 8-hour graphic trend
- 30-minute tabular trend
- 8-hour tabular trend

The printout includes the following data:

- Patient data includes both 30-minute and 8-hour intervals in both graphic and tabular form.
- “New Patient” prints when the unit is put in Standby Mode, or the unit is turned OFF/ON.
- Alarms are not printed.
- FiCO₂ values appear as white marks at the bottom of the CO₂ graph.
- Events are marked with an asterisk “*” beside the time in the tabular trend and with a horizontal line beside the time in the graph.

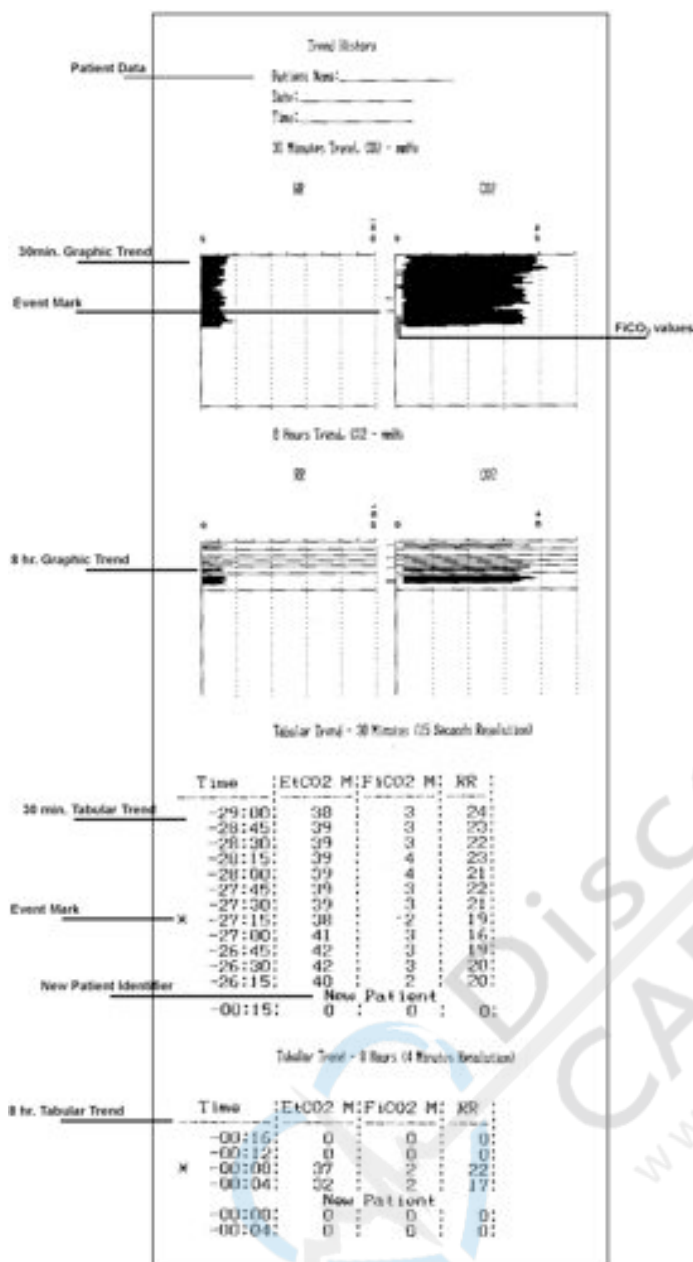

Figure 8: Trend History Printout

Tabular Trend (14 Hr)

During the 14-hour tabular trend period, the data of (up to) the last 100 patients are stored. (A new patient is defined each time the monitor is turned OFF/ON or enters Standby.) The Tabular Trend (14 Hr) option prints at a 5-second resolution, the contents of the stored trend data for the last 14 hours; the EtCO₂, FiCO₂, and Respiratory Rate values.

Note: The stored trend data for the last 14 hours can be downloaded to a PC and a printer. It is not recommended to download 14 hour trend history to a printer due to the large volume of data and the amount of paper that would be required. In order to shorten download time, disconnect the monitor from the patient, put the monitor in Standby mode and start the download process.







The following data is communicated:

- Patient data shows the last 14 hours with a 5-second resolution of trend history in tabular form.
- Alarms are not shown.
- Events are marked with an asterisk "*" beside the time.
- The CO₂ value units are according to the units selected in the Instrument settings menu and are indicated in the header of the table: M = mmHg, K = kPa, V = Vol%.
- "New Patient" appears when the unit is put in Standby Mode, or the unit is turned OFF/ON.

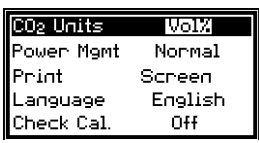
Monitor Setup for Printer/PC Communication

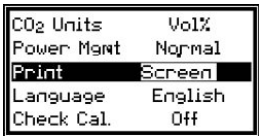
To access and select the monitor functions for communication interface to the Printer or PC, refer to Table 10 below.

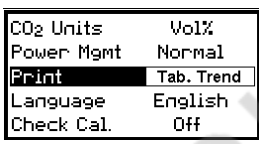
Table 10: Monitor Setup

Objective	Action	Result
Access the Instrument Settings menu from any measuring display.*	 long press (x2)	
Select Print from the <i>Instrument Settings</i> menu.	 short press (x2)	
Change the selected value to the desired print option.	 short press	
Return to any Measuring Mode	 long press	
Print	Refer to Table 12 to start/stop communication to the printer/PC for each option.	

* If after 15 seconds no action is taken, the display returns to the last measuring mode.

COMMUNICATION INTERFACE TO A PRINTER

Important! For printing monitor data, only use the Seiko DPU-414 printer. For further information regarding use of the Seiko DPU-414 printer, refer to its Operation Manual.

WARNING: When using the printer with main line power, it is recommended to use a medical grade power supply complying with the following standards: EN60601-1, UL 2601-1, CSA C22.2 No. 601.1-M90. If the power supply is not medical grade, the printer must be placed at least 1.5 meters from the patient environment complying with standard EN60601-1-1.

The monitor and the Seiko DPU-414 printer must be configured properly before printing will be successful.

Set or check the printer settings (DIP SW) when:

- Using the printer for the first time
- Unsure of the settings
- Configuration has been changed

Note: There are three DIP SW and each has 8 parameters to set.

Printer Setup

To set the printer settings:

1. On the printer, slide the power switch to OFF.
2. While pressing the ON LINE button, slide the printer's power switch to ON. Release the ON LINE button after a list of the current settings starts printing out and the following prompt is printed:.

Continue? : Push 'On-line SW'

Write? : Push 'Paper feed SW'

3. To change the DIP SW settings, press the **ON LINE** button.

To save and exit, press the **PAPER FEED** button.

4. Refer to Table 11 below for the parameter settings for DIP SW-1, DIP SW-2, and DIP SW-3.

To set the setting to **ON**, press the **ON LINE** button once.

To set the setting to **OFF**, press the **FEED** button once.

Note: If you make an error for one of the settings, turn the printer **OFF** when you reach the prompt:

Continue? : Push ‘On-line SW’

Write? : Push ‘Paper feed SW’

Turn the printer **ON** and restart the process.

Table 11: Dip Switch Settings

DIP SW	Parameter	Setting	Feedback
1	1	(OFF)	Input = Serial
	2	(ON)	Printing Speed = High
	3	(ON)	Auto Loading = ON
	4	(OFF)	Auto LF = OFF
	5	(ON)	Setting Command = Enable
	6	(OFF)	Printing
	7	(ON)	Density
	8	(ON)	= 100 %
<p>Continue? : Push ‘On-line SW’ Write? : Push ‘Paper feed SW’ To continue to DIP SW-2, push ON LINE.</p>			

Table 11: Dip Switch Settings, Continued

DIP SW	Parameter	Setting	Feedback
2	1	(ON)	Printing Columns = 40
	2	(ON)	User Font Back-up = ON
	3	(ON)	Character Select = Normal
	4	(ON)	Zero – Normal
	5	(ON)	International
	6	(ON)	Character
	7	(ON)	Set
	8	(OFF)	= U.S.A.= 100 %
Continue? : Push ‘On-line SW’ Write? : Push ‘Paper feed SW’ To continue to DIP SW-3, push ON LINE .			
3	1	(ON)	Data Length = 8 bits
	2	(ON)	Parity Setting = No
	3	(ON)	Parity Condition = Odd
	4	(OFF)	Busy Control = XON/XOFF
	5	(OFF)	Baud
	6	(ON)	Rate
	7	(ON)	Select
	8	(ON)	= 9600 bps
Continue? : Push ‘On-line SW’ Write? : Push ‘Paper feed SW’ Push ON LINE DIP SW setting complete!!			

After receiving the prompt “DIP SW setting complete!!,” the printer is ready to receive information from the monitor. The printer retains DIP SW settings when turned off.







PRINTING

1. Check all cables are properly connected.
2. Turn the printer **ON** and ensure the printer's **ON LINE** green light is on before printing.

Note: If the printer is not connected to the monitor and /or **OFF**, the “**Printer Off Line**” message is displayed on the monitor for 15 seconds.

3. Start and Stop printing as described in Table 12 below.

Table 12: Start/Stop Printing Options

Print Option	Start Print	Stop Print
Screen	Simultaneously long press  and 	Automatically stops after printing is finished.
Tab. Trend (5s) Tab. Trend (1m) Graphic Trend Trend History Tab. Trend (14 hr)	Simultaneously long press  and 	Automatically stops after printing is finished or After simultaneously long pressing  and 

COMMUNICATION INTERFACE TO A PC

Connect the monitor to the PC via the Communication Adapter Kit using the interface cables provided. (For further information refer to the Communication Adapter Kit *Directions for Use*.)

Transferring the Data to the PC

For transferring data to a PC, use any communication software program (i.e. HyperTerminal). Refer to your local distributor to recommend software application options.

The COM property settings should be set as follows, refer to Table 13 below.

Table 13: COM Property Settings

Field Name	Setting
Bits per second	9600
Data bits	8
Parity	None
Flow Control	Xon/Xoff

Downloading the Data

To download:

1. Check all the cables are properly connected.
2. Turn the PC **ON**.

Note: If the printer is not connected to the monitor and /or **OFF**, the “**Printer Off Line**” message is displayed on the monitor for 15 seconds.

3. Follow the directions of the communication software program being used.

TROUBLESHOOTING

Table 14 below lists potential problems and suggestions for resolving them. If the problem persists, contact your local distributor.

Table 14: Troubleshooting Examples

Problem	Solution
"Printer Off Line" message is displayed on the monitor after the print buttons are pressed.	<ul style="list-style-type: none">• Check cables to download device. Make sure they are plugged in correctly and the correct cables are being used.• Ensure the printer is turned on.
Unit will not print and no error message is displayed.	<ul style="list-style-type: none">• Turn off both the printer and the monitor and then turn them back on again. There may have been a data overflow event.• Check DIP switch settings on the printer.• When downloading to a PC, verify that the correct COM port and property settings are selected.

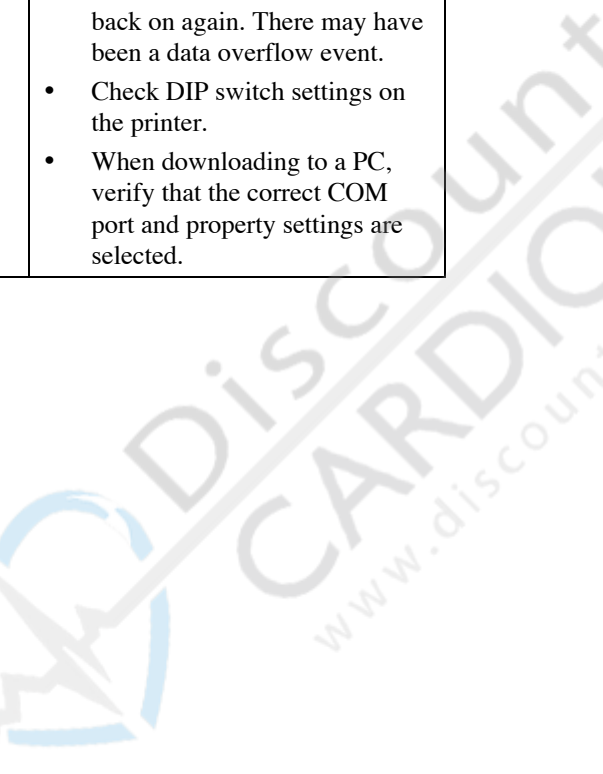

ADDITIONAL INFORMATION

Ordering the Seiko DPU-414 Printer

To order Seiko DPU 414 Printer, contact your local distributor.

Technical Support for the Monitor

For technical support for the monitor and monitor accessories (including the Communication Adapter Kit), please call your local distributor.

Technical Support for the Seiko Printer

For technical support for the Seiko DPU-414 printer, refer to the Seiko printer's Operation Manual.





TROUBLESHOOTING

Alarms and Messages Troubleshooting Guide

This section lists the alarms and messages and the corresponding actions the operator should take. The troubleshooting section discusses potential problems and suggestions for resolving them. If the problem persists and the message remains, contact qualified service personnel or your local distributor.

ALARMS AND MESSAGES

The monitor displays the following four types of alarms and messages in order of priority:

- Warnings
- Cautions
- Advisories
- Silent Advisories

Alarm and Message Priorities

The messages in the following tables (Tables 15 -18) are listed in order of priority.

In the event that several problems occur simultaneously, the higher priority will appear first on the display. After each problem is resolved, the next message is displayed in order of priority.

Warnings

WARNING: Always respond immediately to an alarm since the patient may not be monitored during certain alarm conditions.

Warnings refer to either patient or alarm limit settings problems. They are serious and require immediate operator attention. The message appears on the screen followed by **!!!**, the numerical parameter associated with the alarm blinks, the alarm bar flashes red, and a special, repetitive warning tone is heard.

If one of the following warning messages appears, first check the patient, then check the ventilation equipment (if used), and then check the alarm limits settings (Table 15).

Table 15: Warning Messages

Message	Possible Causes	Action
Apnea xxx !!! *	No valid breath has been detected for xxx seconds.	First check the patient, the connections from patient to the monitor, then ventilation equipment (if used), and then the alarm settings (refer to the <i>Alarm Limits</i> Menu section).
EtCO ₂ ↑ !!!	The EtCO ₂ exceeded the EtCO ₂ high alarm limit.	
EtCO ₂ ↓ !!!	The EtCO ₂ fell below the EtCO ₂ low alarm limit.	
FiCO ₂ ↑ !!!	The FiCO ₂ exceeded the FiCO ₂ high alarm limit.	

*xxx= the number of seconds elapsed since the last valid breath has been detected.

Cautions

Caution messages appear during Measuring Mode and indicate that a problem has occurred requiring the operator's attention. The message appears on screen followed by !!, the alarm bar will flash yellow and a special repetitive caution tone is heard (Table 16).

Table 16: Caution Messages

Message	Possible Causes	Action
Check Unit !!	Instrument fault.	Contact authorized service representative.
Battery ↓ !!	Message appears when battery charge level is very low.	Prepare to replace or recharge battery or connect monitor to AC power.
FilterLine !!	FilterLine is disconnected or not securely connected to the monitor.	Connect FilterLine, to input connector or tighten connection.
Blockage !!	<ul style="list-style-type: none"> - FilterLine is twisted or clogged. The message appears after 30 seconds of unsuccessful purging. - Microstream airway adapter clogged. 	<ul style="list-style-type: none"> - Check the FilterLine and, if necessary, replace it. - Check the Microstream airway adapter and, if necessary, replace it.

Advisory Messages

Advisories are informative messages appearing at start-up before any patient input has been detected by the monitor, or during operation. The message appears on the screen followed by !, the alarm bar will light yellow and a special one-time advisory tone is heard (Table 17).

Table 17: Advisory Messages

Message	Possible Causes	Action
Check Unit !	Instrument fault.	Contact authorized service representative.
Battery Empty !	Battery pack is discharged.	Replace or recharge the battery, or connect to AC power.
Battery ↓ !	Message appears when battery charge level is low.	Prepare to replace or recharge the battery, or connect to AC power.
Purging !	FilterLine tube twisted or clogged with water.	Check the FilterLine and, if necessary, untwist it or replace it.

Silent Advisories

Silent Advisories are instrument status messages indicating the operational state of the monitor or circuits. Silent advisories are low priority signals and only a message appears (with no exclamation marks, nor any other visual or audible indicator) (Table 18).

Table 18: Silent Advisory Messages

Message	Possible Causes	Action
FilterLine	FilterLine is not connected to the instrument. (Message appears before measuring.)	Connect FilterLine to input connector.
Autozero	Monitor automatically performs a zero-point calibration.	No action required.
CO ₂ Warm-up	CO ₂ module is preparing itself for operation.	Wait for “Ready” message before measuring for EtCO ₂ . No action required.
BTPS On Ready	<ul style="list-style-type: none"> • BTPS On - BTPS setting is on. • Ready: CO₂ module is operational but breath is not detected. Note: If BTPS is set to OFF, only Ready appears.	No action required.
6 sec	Patient setting for Adult Mode, or respiration rate is low.	No action required.

Table 18: Silent Advisory Messages, Continued

Message	Possible Causes	Action
3 sec	Patient setting for Adult Mode, or respiration rate is high.	No action required.
Press  To Erase	Trend screen displayed (CO ₂ Trend-8 hrs and CO ₂ Trend 30 min.)	No action required.



TROUBLESHOOTING GUIDE

In Table 19 are potential problems you may experience while using the monitor and suggestions for resolving them. If you are unable to correct the problem, contact qualified service personnel or your local distributor.

Table 19: Troubleshooting Guide

Problem	Cause	Action
Monitor does not turn on.	<ul style="list-style-type: none"> - Power cable improperly attached or disconnected, or cable has faulty electrical connection. - Battery pack's charge may be empty, the battery pack may not be inserted properly or missing. 	<ul style="list-style-type: none"> - Check power cable connection and check that power switch is ON. - Replace or recharge the battery pack, or connect to AC power. Be sure the battery pack is in the monitor and inserted properly.
Monitor switches on but then switches off automatically.	<ul style="list-style-type: none"> - Electrical connection is faulty, or the AC wall outlet has no power. - The battery pack is almost discharged. - One of the monitor's subsystems is out of order. 	<ul style="list-style-type: none"> - Check connections and correct problem. - Replace or recharge battery pack, or connect to AC power. - If previous actions are not effective, contact authorized service representative.
EtCO ₂ values read erratically.	<ul style="list-style-type: none"> - Mechanically ventilated patient who breathes spontaneously. - A leak in the airway. 	<ul style="list-style-type: none"> - No action needed. - Check for connection and line leaks to patient and correct if necessary.

Table 19: Troubleshooting Guide, Continued

Problem	Cause	Action
<p>EtCO₂ values are consistently higher or lower than expected.</p>	<ul style="list-style-type: none"> -Physiological cause. -Ventilator malfunction. -Improper calibration. -BTPS setting ON or OFF. <p>Note: When BTPS is on the correction lowers the EtCO₂ reading to compensate for Body, Temperature, Pressure, and Saturation.</p>	<ul style="list-style-type: none"> -Check patient. -Check ventilator and patient. -Check calibration. See <i>CO₂ Check Calibration</i> section. -Check BTPS setting on the graphic display after Power on. Contact your local service representative.

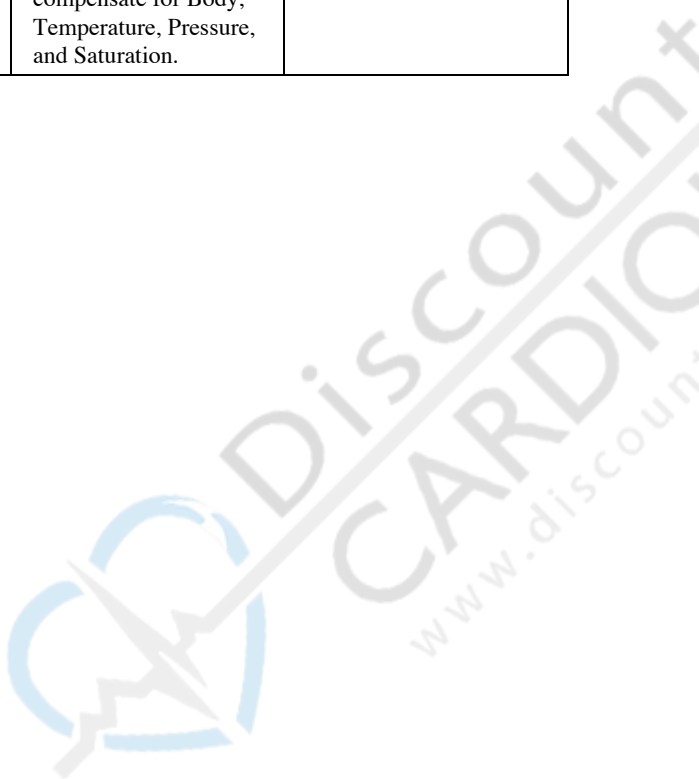

MAINTENANCE

Periodic Maintenance
Service
Cleaning
CO₂ Calibration Check
Returning the Monitor
Technical Assistance

PERIODIC MAINTENANCE





Periodic Maintenance is recommended according to operating hours:

The Pump and Flow System should be replaced every 7,000 operating hours.

The monitor should be returned to the manufacturer for periodic maintenance every 14,000 operating hours.

To check the monitor's operating hours, go to the information screen in the service mode. Table 20 describes how to access the information screen in the service mode.

Table 20: Accessing the Service Mode

Objective	Action	Result
To access the Service Mode	During self-test, press and hold simultaneously  and 	 

A calibration check is recommended once a year.

It is recommended that the battery pack be replaced once every two years.

Note: Contact your local distributor to order spare parts, calibration kits or to answer any questions regarding periodic maintenance.

SERVICE

The monitor requires no routine service other than any performance testing mandated by the operator's institution. The *Troubleshooting* section discusses potential difficulties, their possible causes and suggestions for resolving them. Contact your local distributor for service instructions, and performance tests and checks.

CLEANING

To clean the monitor's surfaces, dampen a cloth with a commercial, nonabrasive cleaner and wipe the top, bottom, and front surfaces lightly.

Caution: Do not spray or pour any liquid directly on the monitor or its circuits.

Caution: Do not use caustic or abrasive cleaners.

Caution: Do not clean the Microstream EtCO₂ Circuits as they are not designed for reuse. These items are for single patient use only.

CO₂ CALIBRATION CHECK

Caution: Do not check CO₂ values from the measuring mode. This mode corrects the CO₂ value for BTPS (Body, Temperature, Pressure, Saturation) which assumes that alveolar gases are saturated with water vapor. The calibration check mode disables this correction.

In order to ensure measurement accuracy, a CO₂ calibration check needs to be done once a year. Calibration gas (available as an optional accessory) and a FilterLine are needed for this procedure, (refer to the *Initial Setup* section). Start the process from the Setup menu as follows in Table 21.

Note: Be sure to attach a FilterLine to the monitor before starting Calibration Check.

Table 21: CO₂ Calibration Check







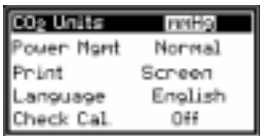

Objective	Action	Result
Access Instrument Settings menu.	 long press (x2)	
Select <i>Check Cal.</i>	 short press(X4)	
Change option to start.	 short press	
Start <i>Check Cal.</i> (When choosing <i>Check Cal.</i> An Autozero process automatically occurs.)	 short press	
Prepare for Cal. Check.	Before connecting the calibration gas, wait 20 minutes. Note: If the monitor has been continuously measuring EtCO ₂ for 20 minutes, you can proceed to “Start Cal Check process”.	EtCO ₂  /min  

Table 21: CO₂ Calibration Check, Continued

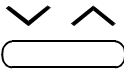

Objective	Action	Result
<p>Prepare for Cal. Check.</p>	<p>Before connecting the calibration gas, wait 20 minutes.</p> <p>Note: If the monitor has been continuously measuring EtCO₂ for 20 minutes, you can proceed to “Start Cal Check process”.</p>	
<p>Start Cal. Check process.</p>	<p>Connect the FilterLine to the calibration gas.</p>	
<p>Check the measured values (shown in Vol% in the EtCO₂ digital display).*</p>	<p>Press the gas valve for 15 seconds until the readings stabilize.</p>	
<p>*Calibration is not required if the measured value is the same as the concentration of the calibration gas ($\pm 5\%$ of reading).</p>		

Table 21: CO₂ Calibration Check, Continued

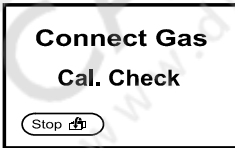
Objective	Action	Result
To return to Measuring Mode if Calibration is not required.	 long press	
If calibration is required, contact your local service representative.		

RETURNING THE MONITOR

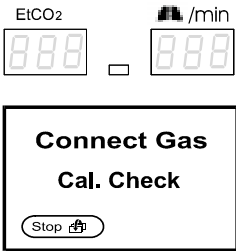
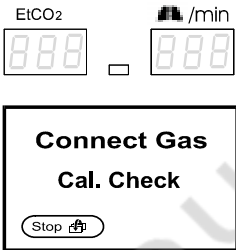
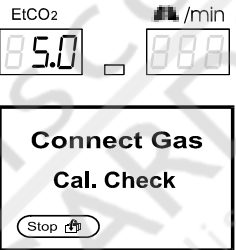
If it is necessary to return the monitor for repairs, call the local distributor for shipping instructions.

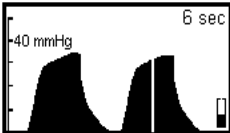
To repack the monitor, disconnect the circuits from the instrument and wrap each item separately. Pack it in the original shipping carton. If the original carton is unavailable, use a suitable box filled with the appropriate amount of packing material. It is not necessary to return the Microstream EtCO₂ circuits.

TECHNICAL ASSISTANCE

For technical information, contact your local distributor.

The service manual includes information that is required by qualified personnel to service the monitor.



Discount

CARDIO

www.discount.com

SPECIFICATIONS

Physical
 Environmental
 Safety Standards
 Performance
 Power Specifications
 Components and User Interface

PHYSICAL

Size

206 mm H x 88 mm W x 53 mm D (8.11”H x 3.46” W x 2.06”D)

Weight (including battery pack)

750 grams (1.66 lb.)

Noise Emission

maximum 45 dB(A)

ENVIRONMENTAL

Temperature

Operating	0°C to 45°C (32°F to 113°F)
Storage	-35°C to 70°C (-31°F to 158°F)

Relative Humidity

10 to 95% (noncondensing)

Pressure and Altitude (for operating and storage)

Pressure	430 mmHg to 795 mmHg
Altitude	-380m to 4,570m (-1,250 ft. to 15,000 ft.)

SAFETY STANDARDS

The monitor was designed to comply with EN60601-1/1990, A1/1993, A2/1995, EN60601-1-1/1992, A1/1996, UL 2601-1 and CSA 22.2 No. 601.1-M90, EN864/1997, ISO9918/1993.

PERFORMANCE

Sampling Rate	50 ±7.5 ml/min.
CO₂ Range	0-99 mmHg (0-13.2 kPa and 0-13.0 Vol%) at sea level
Accuracy EtCO ₂ readings	<p>The CO₂ reading reaches its steady state accuracy 20 minutes after power up.</p> <p>0 - 38 mmHg: (±2 mmHg) 39 - 76 mmHg: (±5% of reading) 77 - 99 mmHg: (±8% of reading)</p> <p>From power-up until steady state is reached, the CO₂ reading accuracy is:</p> <p>0 - 38 mmHg: (±4 mmHg) 39 - 76 mmHg: (±12% of reading) 77 - 99 mmHg: (±12% of reading)</p> <p>Equivalent values for kPa and Vol%</p>
Respiration Rate	0-150 breaths/min.
Warm-up Time	30 seconds (typical)
Frequency Response	EtCO ₂ accuracy is maintained up to 80 breaths/min. (For maintaining accuracy for respiration rate over 60 bpm, use the neonatal mode.) From 81 to 150 bpm accuracy is ±12%, if the EtCO ₂ is higher than 18.8 mmHg in neonatal mode.
System Response Time (delay time)	2.45 seconds (typical), 2.9 seconds maximum
Rise Time neonate	190 msec with low dead space endotracheal tube adapter
adult	240 msce with Microstream airway adapter

Ambient Pressure	Compensated internally - automatic
Alarms	EtCO ₂ high*, EtCO ₂ low*, FiCO ₂ high*, Apnea message

*The accuracy of the these alarms is the same as the accuracy of the EtCO₂ readings.

POWER SPECIFICATIONS

External Power Source

12V DC Medical Grade Adapter

Internal Power Source

Ni-MH Rechargeable Battery Pack 7.2V 2.1 A/h (intended for continuous operation)

Operating Time (fully charged)	Between 3 and 6 hours, depending on power management. These values reflect the performance of a new battery, age and usage will decrease capacity. Note: If the battery pack is stored for 6 months or longer, you must charge and discharge it (leave unit on, not connected to AC power, until battery is empty) three times before use in order to ensure full capacity.
Recharging Period	Approximately 4.5 hours internal recharging
Charger Type	Internal

COMPONENTS AND USER INTERFACE

Displays

Graphic LCD display	(128 x 64 dots) with LED backlight dimension 75 mm x 53 mm.
Two numeric fields	3 digits each, using 7-segment LED dimension 22 mm x 14 mm.
Alarm bar	yellow, red

Controls and Indicators

Front Panel	ON/OFF switch; Alarm Silence/Alarm Menu button; Contrast/Value change button; Event/Home button; Next/Menu button.
--------------------	--

Connections

Front Panel	CO ₂ Input connector
Rear Panel	Clamp connector
Side Panel	Socket for AC Adapter or Communication Adapter, Gas outlet

