

EDAN Agile PLM Electronic Signature Information

--Signatures related to this document and performed in EDAN Agile PLM.

文件名称(Document Name) : F6维修手册_英文

文件编号(Number) : 01.54.456559

版本(Version) : 1.4

产品型号(Product Model) : F6 Express;F6

项目编码(Project Code) : 2040A000

签批信息(Signature):

作者(Originator) : 周睿 (zhourui) 2019-06-25 13:35:07

审核人(Reviewers) : 刘小倩 (liuxiaoqian) 2019-06-26 18:04:29

审核人(Reviewers) : 唐林 (tanglin) 2019-06-25 14:14:39

审核人(Reviewers) : 廖为塔 (liaoweita) 2019-06-27 11:29:45

批准人(Approvers) : 夏欢欢 (xiahuanhuan) 2019-07-09 15:46:29

批准人(Approvers) : 吴明花 (wuminghua) 2019-07-09 14:48:25

F6, F6 Express

Fetal & Maternal Monitor

Service Manual

CE₀₁₂₃

EDAN

About this Manual

P/N: 01.54.456559

MAN: 01.54.456559014

Release Date: Jun 2019

© Copyright EDAN INSTRUMENTS, INC. 2008 - 2019. All rights reserved.

Statement

This manual will help you understand the operation and maintenance of the product better. It is reminded that the product shall be used strictly complying with this manual. User's operation failing to comply with this manual may result in malfunction or accident for which Edan Instruments, Inc. (hereinafter called EDAN) can not be held liable.

EDAN owns the copyrights of this manual. Without prior written consent of EDAN, any materials contained in this manual shall not be photocopied, reproduced or translated into other languages.

Materials protected by the copyright law, including but not limited to confidential information such as technical information and patent information are contained in this manual, the user shall not disclose such information to any irrelevant third party.

The user shall understand that nothing in this manual grants him, expressly or implicitly, any right or license to use any of the intellectual properties of EDAN.

EDAN holds the rights to modify, update, and ultimately explain this manual.

Responsibility of the Manufacturer

EDAN only considers itself responsible for any effect on safety, reliability and performance of the equipment if:

Assembly operations, extensions, re-adjustments, modifications or repairs are carried out by persons authorized by EDAN, and

The electrical installation of the relevant room complies with national standards, and

The instrument is used in accordance with the instructions for use.

EDAN will make available on request circuit diagrams, component part lists, descriptions,

calibration instructions, or other information that will assist SERVICE PERSONNEL to repair those parts of ME EQUIPMENT that are designated by EDAN as repairable by SERVICE PERSONNEL.

Using This Label Guide

This guide is designed to give key concepts on safety precautions.

WARNING

A **WARNING** label advises against certain actions or situations that could result in personal injury or death.

CAUTION

A **CAUTION** label advises against actions or situations that could damage equipment, produce inaccurate data, or invalidate a procedure.

NOTE

A **NOTE** provides useful information regarding a function or a procedure.

Table of Contents

Chapter 1 Warranty and Service	1
Chapter 2 Overview	4
2.1 Introduction	4
2.2 General Information	4
2.3 Safety Precautions	5
Chapter 3 Installation	8
3.1 Environment Requirements.....	8
3.2 Electrical Requirements	9
3.3 Safety Requirements	9
3.4 Installing the Monitor.....	9
3.4.1 Installing the Monitor on a Flat Surface.....	9
3.4.2 Mounting the Monitor on a Wall.....	10
3.4.3 Installing the Monitor on a Roll Stand/Trolley	11
3.5 Connecting to AC Power.....	11
Chapter 4 Functional Checks	12
4.1 Switching on Check	12
4.2 LCD Screen Check.....	12
4.3 Keys Check	12
4.4 Printing Check.....	12
4.5 Alarms Check.....	13
Chapter 5 System Configuration	14
5.1 Opening System Setup Menu	14
5.2 Entering Demo Mode	14
5.3 Reloading Default Settings.....	14
5.4 Clearing Data.....	15
5.5 Checking Product Information	15
5.6 Changing the Device No.	15
5.7 Changing Net Version.....	16
5.8 Configuring 485 Wireless Network	16
5.9 Configuring for Ethernet Connecting.....	17
5.10 Changing Trace Width	18
5.11 Changing Paper Style	18
5.12 Changing the Language.....	18
5.13 Changing FHR Algorithm.....	19
5.14 Pressure Verification	19
5.15 NIBP Leak Test	19
5.16 NIBP Calibration.....	19
Chapter 6 Maintenance	21
6.1 Maintenance Inspection.....	21
6.2 Maintenance of the Monitor	22
6.3 Maintenance of the Transducers	22
6.4 Maintenance of the Recorder	22

Chapter 7 Principle Introduction	23
7.1 System Principle Block Diagram	23
7.1.1 Main Control Board	23
7.1.2 Fetal Monitor Module	24
7.1.3 DECG Module.....	26
7.1.4 ECG Module	26
7.1.5 NIBP Module	27
7.1.6 SpO ₂ (A8 ⁺) Module.....	27
7.1.7 Print Controlling Board.....	28
7.1.8 Power Interface Board.....	29
7.1.9 Power Module	30
7.1.10 Key Board	31
7.1.11 Interfaces Board	31
7.1.12 LVDS LCD	35
7.1.13 LCD Backlight Board.....	36
7.1.14 LCD Driving Board.....	36
7.2 Interfaces	36
7.2.1 DB9/D-Sub Interface.....	36
7.2.2 RJ45 Interface	36
7.2.3 Antenna	37
Chapter 8 Troubleshooting	38
8.1 Monitor Booting Failures	38
8.2 Display Failures.....	39
8.3 Operation Failures	39
8.4 Recorder Failures	39
8.5 Network Failures	40
8.6 Alarm Failures.....	40
8.7 Technique Alarms	41
8.8 FHR/TOCO Monitoring Failures	42
8.9 DECG/IUP Monitoring Failures	42
8.10 ECG Monitoring Failures.....	42
8.11 SpO ₂ Monitoring Failures	43
8.12 NIBP Monitoring Failures.....	43
8.13 TEMP Monitoring Failures	43
Chapter 9 Modules' Malfunction Verification	44
9.1 Verifying Malfunction of the Main Control Board.....	44
9.2 Verifying Malfunction of the FM Module	45
9.3 Verifying Malfunction of the Power Module.....	46
9.4 Verifying Malfunction of the Main Parameter Module	47
9.5 Verifying Malfunction of the Multi-Parameter Module	48
9.6 Verifying Malfunction of the Print Controlling Module.....	49
9.7 Verifying Malfunction of the DECG Module	50
Chapter 10 Disassembling the Monitor.....	52
10.1 Tools Required	52
10.2 Replacing Fuses.....	52
10.3 Disassembling the Main Unit.....	53
10.4 Disassembling the Lower assembly	54

10.4.1 Replacing the FM Module.....	54
10.4.2 Replacing the Print Controlling Board.....	55
10.4.3 Replacing the Gear Assembly	56
10.4.4 Replacing the Speaker	57
10.4.5 Replacing the Power Module	57
10.4.6 Replacing the Fan.....	58
10.4.7 Replacing the Power Interface Board.....	59
10.4.8 Replacing the NIBP Module	59
10.4.9 Replacing the SpO ₂ Module.....	60
10.4.10 Replacing the F9 X12-EDAN NIBP Board	61
10.4.11 Replacing the Main Parameter Module Interface Board.....	61
10.4.12 Replacing the Printhead	62
10.5 Disassembling the Upper Assembly	64
10.5.1 Replacing the Main Control Board	64
10.5.2 Replacing the Key Board	65
10.5.3 Replacing the LCD.....	66
10.5.4 Replacing the Power Inverter Board	69
Chapter 11 Periodic Tests.....	70
11.1 Safety Tests	70
11.2 Performance Tests	70
11.2.1 FHR Performance Test.....	70
11.2.2 TOCO Performance Test.....	71
11.2.3 ECG Performance Test.....	71
11.2.4 SpO ₂ Performance Test	72
11.2.5 NIBP Performance Test	72
11.2.6 TEMP Performance Test.....	73
Appendix 1 Renewal Parts	74
Appendix 2 Connecting to OB TraceVue System	75

Chapter 1 Warranty and Service

Standard Service

EDAN provides a one-year-warranty for the warranted products (accessories are included). The warranty period begins on the date the products are shipped to customers. If a customer promptly notifies EDAN of customer's warranty claim hereunder, EDAN will either repair, adjust or replace (with new or exchange replacement parts) EDAN's products. EDAN warrants that any service it provides to customers will be performed by trained individuals in a workmanlike manner.

Limitation of Warranty

Direct, indirect or final damage and delay caused by the following situations for which EDAN is not responsible may void the warranty:

- ✧ Groupware is dismantled, stretched or redebugged.
- ✧ Unauthorized modification or misuse.
- ✧ Damage caused by operating beyond the environmental specifications for the medical product.
- ✧ Change or remove original serial number label or Manufacturer symbol.
- ✧ Improper use.

Service Procedure

(1) Fill in the **Service Claim Form (SCF)**.

Fill in the SCF with detailed information including: **Model Name, Serial Number (SN)** and **Problem Phenomena**.

EDAN should not have any obligation to take over the case without this information. The form can be downloaded at: <http://www.edan.com.cn> or obtained from EDAN's Service Department.

(2) Send EDAN the SCF and Select a Solution.

Once the service department receives the fully filled SCF, EDAN's engineer will offer a solution in three working days. EDAN will follow out the case based on the two conditions below:

Within Warranty:

There are two options:

i) After receiving the **Return Material Authorization (RMA)** form from EDAN service department, the customer sends EDAN the defective parts and informs about the shipment tracking number. Then we will dispatch new part(s) to your confirmed address with confirmed shipping invoice.

ii) The customer signs the **Declaration Form** and sends it back by email or fax. This form is legally certificated to make sure the customer or end-user will return the defective parts to EDAN on time. We will, at this option, dispatch the replacement one(s) with confirmed shipping invoice.

NOTE:

- 1 Both Return Material Authorization Form and Declaration Form are offered by EDAN service department once the SCF is confirmed by service engineer.
- 2 The customer is responsible for freight & insurance charges when the equipment is shipped to EDAN for service, including custom charges. EDAN is responsible for the freight, insurance & custom charges from EDAN to the customer.

Out of Warranty:

After receiving the RMA form from the service department, the customer sends defective parts to EDAN in advance. We will analyze the problems and discuss with the customer about either repairing or replacing the part(s). Once the maintenance fee is invoiced and paid, we will make sure to dispatch good part(s) to the confirmed address.

NOTE: The customer is responsible for any freight & insurance charge for the returned product.

(3) Obtain the RMA Form.

Before the shipment of the materials, the customer must obtain an RMA form from our service department, in which the RMA number, description of returning parts and shipping instructions are included. The RMA number should be indicated on the outside of the shipping container.

NOTE: EDAN should not have any obligation to the end-user or customer who returns the goods without the notification by EDAN's service department. The sender takes full responsibility for the accounted fee.

(4) Send the Parts to EDAN.

Follow these recommended instructions:

- ✧ Please disassemble the parts with anti-static facility, do not touch the parts with naked hand.
- ✧ Please pack the parts safely before return.
- ✧ Please put the RMA number on the parcel.
- ✧ Please describe the returned parts as 'sample of *****' and put the total value on the invoice, and note on the invoice as 'sample, no commercial value'.
- ✧ Please confirm the invoice with EDAN before shipment.
- ✧ Please send back the parts after EDAN's confirmation.

Contact Information

If you have any question about maintenance, technical specifications or malfunctions of devices, do not hesitate to contact us.

EDAN Instruments, Inc.

TEL: +86-755-26898321, 26899221

FAX: +86-755-26882223, 26898330

E-mail: support@edan.com.cn

Chapter 2 Overview

NOTE:

This service manual is written to cover the maximum configuration. Therefore, your model may not have some of the parameters/modules described, depending on what you have ordered.

2.1 Introduction

This service manual is a reference for periodic preventive maintenance and corrective service procedures for the **F6** and **F6 Express** fetal & maternal monitor.





It provides troubleshooting information, assembly procedures, instructions for functional testing and performance verification. It is intended for use only by technically qualified service personnel.

WARNING

When performing a service procedure, follow the instructions exactly as presented in this manual. Failure to do so might damage the monitor, invalidate the product warranty or lead to serious personal injury.

2.2 General Information

- ◆ **F6, F6 Express** Fetal & Maternal Monitors (hereinafter called **F6, F6 Express**) are designed to comply with the international safety requirements IEC/EN 60601-1 for medical electrical equipment. It is class I equipment.
- ◆ The protective degree against electric shock of the patient connections is:

Ultrasound (FHR1, FHR2) External TOCO Intrauterine Pressure (IUP) Fetal Movement Mark (FM) Fetal Stimulator ((FS)	Type BF	
Non-invasive Blood Pressure (NIBP) Arterial Oxygen Saturation (SpO ₂)	Type BF, defibrillation-proof	
Direct Electrocardiography (DECG)	Type CF	
Electrocardiography (ECG) Temperature (TEMP)	Type CF, defibrillation-proof	

The monitor described in this user manual is not protected against:

- ◆ The effects of high frequency currents
- ◆ The interference of electrosurgery equipment

2.3 Safety Precautions

WARNING and **CAUTION** messages must be observed. To avoid the possibility of injury, observe the following precautions during the maintaining the instrument.

WARNING

- 1 **F6, F6 Express** must be serviced by authorized and qualified personnel only. EDAN do not accept responsibility for safety compliance, reliability and performance if modifications or repairs are carried out by unauthorized personnel. Identical replacement parts must be used.
 - 2 The service personnel should be familiar with the operation of this monitor. Refer to *User Manual* of the monitor for details.
 - 3 **EXPLOSION HAZARD** - Do not use the monitor in the presence of flammable anesthetics or other materials.
 - 4 **SHOCK HAZARD** - the power receptacle must be a three-wire grounded outlet. Never try to adapt the three-prong plug to fit a two-slot outlet. A hospital grade outlet is required. If the outlet has only two slots, make sure that it is replaced with a three-slot grounded outlet before attempting to operate the monitor.
 - 5 Any non-medical equipment (such as the external printer) is not allowed to be used within the patient vicinity (1.5m/6ft.).
 - 6 Do not use the additional multiple portable socket-outlet or extension cord in the medical electrical system, unless it's specified as part of the system by manufacturer. And the multiple portable socket-outlets provided with the system shall only be used for supplying power to equipment which is intended to form part of the system.
 - 7 If multiple instruments are connected to a patient, the sum of the leakage currents may exceed the limits given in the IEC/EN 60601-1 and may pose a safety hazard. Consult your service personnel.
 - 8 Multiple portable socket-outlets shall not be placed on the floor.
-
-

WARNING

- 9 Make sure that the power is turned off and the power cord is disconnected from the AC socket before connecting or disconnecting equipment. Otherwise, the patient or operator may receive electrical shock or other injury.
 - 10 Do not connect any equipment or accessories that are not approved by the manufacturer or that are not IEC 60601-1 approved to the monitor. The operation or use of non-approved equipment or accessories with the monitor is not tested or supported, and monitor operation and safety are not guaranteed.
 - 11 **SHOCK HAZARD** - Don't connect non-medical electrical equipment, which has been supplied as a part of the system, directly to the wall outlet when the non-medical equipment is intended to be supplied by a multiple portable socket-outlet with an isolation transformer.
 - 12 **SHOCK HAZARD** - Don't connect electrical equipment, which has not been supplied as a part of the system, to the multiple portable socket-outlets supplying the system.
 - 13 Do not use the additional multiple portable socket-outlet or extension cord in the medical electrical system, unless it's specified as part of the system by manufacturer. And the multiple portable socket-outlets provided with the system shall only be used for supplying power to equipment which is intended to form part of the system.
 - 14 Do not exceed the maximum permitted load when using multiple portable socket-outlets to supply the system.
 - 15 Do not touch accessible parts of non-medical electrical equipment and the patient simultaneously.
 - 16 Do not switch on the monitor until all cables have been properly connected and verified.
 - 17 Do not touch the signal input or output connector and the patient simultaneously.
 - 18 Equipment and devices that connect to the monitor should form an equipotential body to ensure effective grounding.
 - 19 Disconnect the power cord before changing fuses. Replace them with those of the same specifications only.
 - 20 **SHOCK HAZARD** - Do not attempt to connect or disconnect a power cord with wet hands. Make certain that your hands are clean and dry before touching a power cord.
 - 21 **SHOCK HAZARD** - Do not remove the top panel cover during operation or while power is connected.
-
-

WARNING

- 22 Only connect accessories supplied or recommended by the manufacturer to the device.
 - 23 Accessory equipment connected to the analog and digital interfaces must be certified according to the respective IEC/EN standards (e.g. IEC/EN 60950 for data processing equipment and IEC/EN 60601-1 for medical equipment). Furthermore all configurations shall comply with the valid version of the system standard IEC/EN 60601-1. Anybody who connects additional equipment to the signal input connector or signal output connector to configure a medical system must ensure that the system complies with the requirements of the valid version of the system standard IEC/EN 60601-1. If in doubt, consult our technical service department or your local distributor.
 - 24 Parts and accessories used must meet the requirements of the applicable IEC 601 series safety standards, and/or the system configuration must meet the requirements of the IEC 60601-1 medical electrical systems standard.
 - 25 Connect the grounding wire to the equipotential grounding terminal in the main system. If it is not evident from the instrument specifications whether a particular instrument combination is hazardous or not, for example due to summation of leakage currents, you should consult the manufacturer or an expert in the field, to ensure that the necessary safety of all instruments concerned will not be impaired by the proposed combination.
 - 26 Electromagnetic Interference - Ensure that the environment in which the monitor is installed is not subject to any source of strong electromagnetic interference, such as CT, radio transmitters, mobile phone base stations, etc.
 - 27 When installing the unit into a cabinet, allow for adequate ventilation, accessibility for servicing, and room for adequate visualization and operation.
 - 28 Keep the environment clean. Avoid vibration. Keep it far from corrosive medicine, dust area, high-temperature and humid environment.
-
-

Chapter 3 Installation

WARNING

Only qualified service engineers should install this equipment.

3.1 Environment Requirements

Working Environment	
Temperature:	+5 °C ~ +40 °C (+41 °F ~ +104 °F)
Relative Humidity:	15% ~ 93% (non-condensing)
Atmospheric Pressure:	86 kPa ~ 106 kPa
Transport and Storage	
Temperature:	-20 °C ~ +55 °C (-4 °F ~ +131 °F)
Relative Humidity:	15% ~ 93% (non-condensing)
Atmospheric Pressure:	70 kPa ~ 106 kPa
Classification	
Anti-electric Shock Type:	Class I equipment with internal power supply
Anti-electric Shock Degree:	FHR1, FHR2, TOCO, IUP, FM BF SpO ₂ , NIBP BF (Defibrillating-proof) DECG CF ECG, TEMP CF (Defibrillating-proof)
Degree of Protection against Harmful Ingress of Water:	Main Unit: IPX1, protected against vertically falling water drops (provided recorder drawer is shut and the monitor is not mounted on the wall vertically) US/TOCO Transducers: IPX8, protected against the effects of continuous emersion in water
Degree of Safety in Presence of Flammable Gases:	Equipment not suitable for use in presence of flammable gases
Disinfection/Sterilizing Method:	Refer to <i>User Manual</i> for details
EMC:	Group I Class A
Working System	Continuous running equipment

- ◆ If the monitor is installed in a cabinet, allow at least 2 inches (5 cm) clearance around

the monitor for proper air circulation; allow adequate accessibility for servicing, and adequate room for visualization and operation.

- ◆ Ensure the monitor is not subject to any source of strong electromagnetic interference, such as CT, radio transmitters, mobile phones base stations, etc.
- ◆ Do not install the monitor in a flammable atmosphere where concentrations of flammable anesthetics or other materials may occur.
- ◆ Keep the environment clean. Avoid vibration. Keep it far from corrosive medicine, dust area, high-temperature and humid environment.

3.2 Electrical Requirements

Operating Voltage:	100V-240V ~
Operating Frequency:	50Hz/60Hz
Input Power:	1.0A-0.5A
Battery:	14.8VDC/5000mAh

3.3 Safety Requirements

- ◆ **SHOCK HAZARD-** The power receptacle must be a three-wire grounded outlet. A hospital grade outlet is required. Never adapt the three-prong plug from the monitor to fit a two-slot outlet. If the outlet has only two slots, make sure that it is replaced with a three-slot grounded outlet before attempting to operate the monitor.
- ◆ Do not touch signal input or output connector and the patient simultaneously.
- ◆ Equipment and devices that connect to the monitor should form an equipotential body to ensure effective grounding.
- ◆ Do not switch on the monitor until all cables have been properly connected and verified.

3.4 Installing the Monitor

3.4.1 Installing the Monitor on a Flat Surface.

Place the monitor on a flat surface. Make sure the surface does not vibrate, and is free of corrosive medicine and dust.

3.4.2 Mounting the Monitor on a Wall

To mount the monitor on a wall,

- 1 Order a wall mounting board (01.52.107983) and a connecting board (01.52.107984) from the manufacturer.
- 2 Turn the monitor over and fix the connecting board to the bottom panel using two pan head screws.

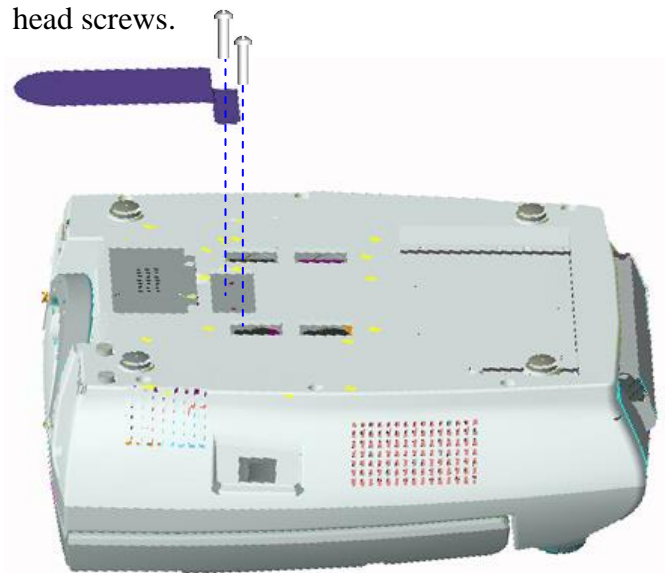

Figure 3-1 Fixing Connecting Board

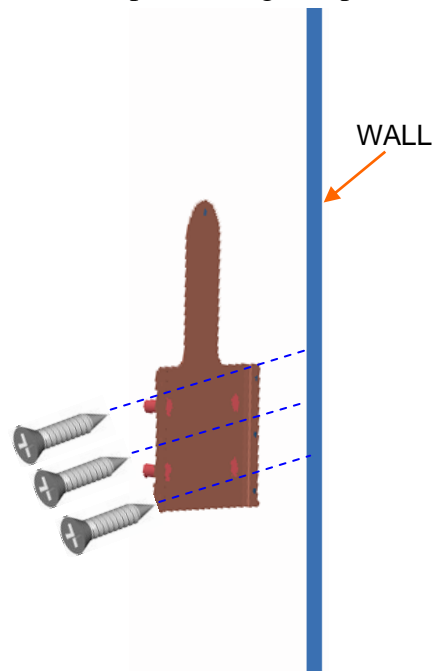

Figure 3-2 Fixing Wall Mounting Board

- 3 Fix the wall mounting board to the wall with six self-tapping screws.
- 4 Lift the monitor with the bottom panel facing the wall. Let the four posts on the board stretch into wall-mounting holes and then release your hands from the monitor slowly.
- 5 Secure the connecting board to the wall mounting board with a pan head screw.



Figure 3-3 Securing Two Boards

CAUTION

- 1 The monitor should only be mounted on a solid concrete or brick wall.
 - 2 Shut the display completely flat before mounting the monitor to the wall.
 - 3 Make sure the wall mounting board is firmly fixed to the wall. If there is any doubt, do not hang the monitor to this board.
 - 4 Make sure the monitor is safely hung on the posts of the board before releasing your hands from the monitor.
-
-

3.4.3 Installing the Monitor on a Roll Stand/Trolley

An Assembling Instruction will be delivered with the roll stand/trolley. Refer to that instruction for details of installing the monitor on a roll stand/trolley.



Figure 3-4 The Monitor on a Trolley (Sketch Map)

3.5 Connecting to AC Power

Apply the power cable provided with the monitor. Plug one end of the power cable to the power socket of the monitor. Connect the other end to a grounded 3-slot power output special for hospital usage.

Chapter 4 Functional Checks

This section describes the procedure of a complete functional test to support recommended preventive-maintenance schedules.

You are not required to open the device case for functional checks.

WARNING

Only qualified service personnel should perform a full functional check procedure.

Whenever the monitor is serviced or problems are suspected, the manufacturer recommends a full functional check procedure.

4.1 Switching on Check

Press the **POWER** switch on the right panel to switch on the monitor.

Check if the power indicator lights up, if a start-up tone is heard, and if the screen lights up in a few seconds.

If any failure is detected, refer to section *8.1 Monitor Booting Failures* for details.

4.2 LCD Screen Check

Observe if some characters are missing, or if there are bright spots and dark shadows on the LCD screen. Observe if the waveforms, fonts and symbols displayed on the LCD screen are normal.

If any failure is detected, refer to section *8.1 Monitor Booting Failures* for details.

4.3 Keys Check

Press the keys on the front panel to check if they work properly. When pressing a key, a normal key tone should be heard, unless its related function is disabled.

If any failure is detected, refer to section *8.2 Display Failures* for details.

4.4 Printing Check

Press the **PRINT** key to start printing. Check if the recorder starts printing.

Enable the **Print Self-Test** function. Restart the monitor and verify if the recorder prints a baseline.

Enter **DEMO** mode and print some traces and check if all the traces are clear on the paper.

If any failure is detected, refer to section *8.4 Recorder Failures* for details.

NOTE:

Please make sure the paper loading and setting are correct before the printing starts.

4.5 Alarms Check

Stimulate a signal that is higher than the upper limit or lower than the lower limit to activate a physical alarm. Disconnect one of the plugs off the monitor to activate a technical alarm. Check if the audible alarms and visible alarms are working properly.

If any failure is detected, refer to section *8.6 Alarm Failures* for defective details.

Chapter 5 System Configuration

The end users can not change the system configurations of the monitor. As a service engineer, you need to change these configurations for them after the monitor is installed and checked properly.

NOTE:

Restart the monitor after changing the settings.

5.1 Opening System Setup Menu

The system configurations of the monitor are to be changed in the system setup menu. To open this menu,

- 1 Select the setup key  on the main interface.
- 2 Select **System**.
- 3 Input the password **9999** on the soft keyboard.
- 4 Select **Enter** on the soft keyboard.

5.2 Entering Demo Mode

The monitor works in real-time monitoring mode when monitoring a patient. If you want to show the traces and parameters for a demonstration, you need to enter the **Demo** mode.

- 1 Open the System Setup menu.
- 2 Select **Demo**.
- 3 Select **OK**.

5.3 Reloading Default Settings

The default settings are predefined in the factory. Users can change the monitor setup, but this default configuration stays the same. To reload this default,

- 1 Open the System Setup menu.
- 2 Select **Default**.
- 3 Select **OK**.

5.4 Clearing Data

The auto-saved data is saved in the monitor memory. In order to delete this data,

- 1 Open the System Setup menu.
- 2 Select **Clear Data**.
- 3 Select **OK**.

5.5 Checking Product Information

The product information menu lists the hardware and software information of this monitor. This information can be very helpful when contacting the manufacturer for service.

To check the product information,

- 1 Open the System Setup menu.
- 2 Select **Product Information**.

5.6 Changing the Device No.

This device No. determines the bedside monitor ID on the data receiving software, such as MFM-CNS central monitoring system of EDAN.

- 1 Open the System Setup menu.
- 2 Select **Network Setup**.
- 3 Select the pane next to **Device No.**.
- 4 Select a device number from 1 ~ 99.
- 5 Select **OK** in the Network Setup menu.
- 6 Select **OK** in the System Setup menu.

CAUTION

Make sure the device numbers of the monitors in the same system do not overlap.

5.7 Changing Net Version

This Net version determines the network protocol of monitor when it is connecting to a PC.

Connecting Mode	Other Requirements	Net Version
F6 connects to MFM-CNS via DB9 interface.	MFM-CNS version is V3.0 or higher	RS485 V1.1
	MFM-CNS version is V3.3 or higher	RS485 V1.2
	MFM-CNS version is V3.7 or higher	RS485 V1.3
F6 connects to Insight software via DB9 interface.	---	INSIGHT V1.2
F6 connects to MFM-CNS or Insight software via Ethernet.	MFM-CNS version is V3.4 or higher	ETHERNET V1.2
F6 connects to MFM-CNS or Insight software via Wi-Fi wireless network.	MFM-CNS version is V3.4 or higher	ETHERNET V1.3
F6 connects to OB TraceVue system of PHILIPS.	---	PHILIPS
F6 connects to FetalCare system.	---	FetalCare
F6 connects to QS system.	---	QS
F6 connects to MILOU system via DB9 interface.	---	MILOU-RS232
F6 connects to MILOU system via Ethernet.	---	MILOU-ETHERNET

- 1 Open the System Setup menu.
- 2 Select **Network Setup**.
- 3 Select the pane next to **Net Version**.
- 4 Select a net version.
- 5 Select **OK** in the Network Setup menu.
- 6 Select **OK** in the System Setup menu.

5.8 Configuring 485 Wireless Network

When connecting the monitor to MFM-CNS via 485 wireless network, you need to set wireless channel number and wireless module number:

- 1 Open the System Setup menu.

- 2 Select **Network Setup**.
- 3 Select **Wireless CH**.
- 4 Select a number (6 ~ 31).
- 5 Select **Wireless MOD**.
- 6 Select a number (0 ~ 31).
- 7 Select **OK** in the Network Setup menu.
- 8 Select **OK** in the System Setup menu.

NOTE:

Refer to *MFM-CNS Wireless Network Installation Guide* for details of setting 485 wireless network.

5.9 Configuring for Ethernet Connecting

NOTE:

Only when you have selected one of the Ethernet protocols for Net Version, such as Ethernet V1.2 or Ethernet V1.3, can you proceed to Ethernet connecting settings.

When connecting the monitor to a PC via Ethernet, you need to set the server IP, monitor IP, subnet mask, default gateway and Ethernet port:

- 1 Open the System Setup menu.
- 2 Select **Network Setup**.
- 3 Select **Server IP**.
- 4 Set the IP address to be the same as that of the PC.
- 5 Select **Monitor IP**.
- 6 Set the IP address of the monitor for Ethernet connection.
- 7 Select **Subnet Mask**.
- 8 Set the subnet mask of the monitor for Ethernet connection.
- 9 Select **Default Gateway**.
- 10 Set the default gateway of the monitor for Ethernet connection.
- 11 Select **Ethernet Port**.
- 12 Set the port number to be the same as that of the software.
- 13 Select **OK** in the Network Setup menu.
- 14 Select **OK** in the System Setup menu.

5.10 Changing Trace Width

In order to differentiate the traces clearly, you may assign different widths for different traces.

- 1 Open the System Setup menu.
- 2 Select **Recorder Configuration**.
- 3 Select **FHR1**.
- 4 Select a number from **1, 2, 3** and **4**. The width of the trace increases by degrees from **1** to **4**.
- 5 Set width of FHR2, AFM, TOCO, HR and SpO₂ traces in the same way.
- 6 Select **OK** in the Recorder Configuration menu.
- 7 Select **OK** in the System Setup menu.

5.11 Changing Paper Style

The paper style determines the range of FHR trace background pane bar. Observe the recorder paper that the user has ordered, 30 ~ 240 is USA style; 50 ~ 210 is International style.

- 1 Open the System Setup menu.
- 2 Select **Recorder Configuration**.
- 3 Select the pane next to **Paper Style**.
- 4 Select the required style from **USA** and **International**.
- 5 Select **OK** in the Recorder Configuration menu.
- 6 Select **OK** in the System Setup menu.

CAUTION

To avoid inconsistency between FHR traces on the recorder paper and those on the screen, the paper style must comply with the style of the recorder paper being used.

5.12 Changing the Language

The software supports several languages.

- 1 Open the System Setup menu.
- 2 Select **Language**.
- 3 Select the required language.
- 4 Select **OK**.

5.13 Changing FHR Algorithm

The **Beat-to-beat** FHR algorithm provides vivid short-term variation information of the fetal heart rate. The **Average** FHR algorithm provides a smoothed FHR trace.

- 1 Open the System Setup menu.
- 2 Select **Beat-to-beat** or **Average**.
- 3 Select **OK**.

5.14 Pressure Verification

Pressure Verification enables the *Pressure Verif mode*, in which you can verify whether there is a problem with the NIBP measurement.

- 1 Open the System Setup menu.
- 2 Select **Pressure Verif**.

NOTE:

Make sure neither NIBP measuring nor NIBP leak test is being performed before you enable pressure verification. If you need to disable pressure verification, please open the System Setup menu and press **Pressure Verif** again. In addition, you should restart the system after the pressure verification is finished.

5.15 NIBP Leak Test

NIBP Leak Test checks whether there is leak during NIBP measuring.

- 1 Open the System Setup menu.
- 2 Select NIBP Leak Test.

NOTE:

Make sure neither NIBP measuring nor pressure verification is being performed before you enable NIBP leak test. Once the leak test is enabled, it can't be stopped manually. It will automatically stop after it is finished and a message box will prompt out to inform you whether the test has passed or not. In addition, you should restart the system after the NIBP leak test is finished.

5.16 NIBP Calibration

NOTE:

- 1 NIBP calibration must be performed by professional personnel authorized by EDAN.
- 2 NIBP calibration can influence measurement results. Incorrect operation may

influence measurement accuracy.

- 3 NIBP calibration can only be performed when none of NIBP measuring, pressure verification and NIBP leak test is being performed.

Tools required:

- T-fitting
- NIBP extension tubes
- Cylinder (200 ml)
- Manometer (Its measurement range should be within the range of 0 mmHg to 300 mmHg; its accuracy should be more precise than the accuracy of ± 0.3 mmHg.)

Procedure:

- 1 Connect the equipment as shown below:

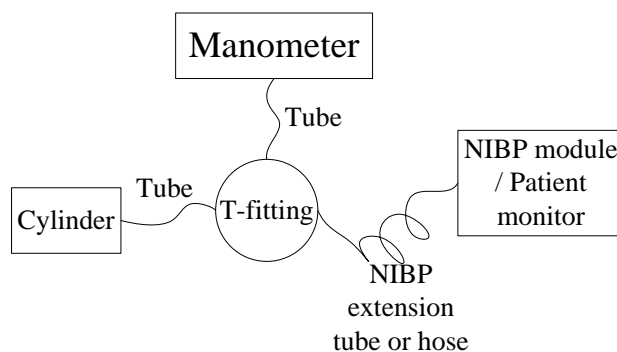

Figure 5-1 Diagram for NIBP Calibration

- 2 Open the **System** setup menu.
- 3 Select **NIBP Calibration** from the menu.
- 4 Select **Calibrate Initialization** to start calibration.
- 5 Adjust the manometer value to 50 mmHg (If different values are required for calibration, keep the value of the manometer consistent with the one displayed on the monitor). After the value of the manometer stabilizes, select **Calibrate Low**.
- 6 Adjust the manometer value to 250 mmHg (If different values are required for calibration, keep the value of the manometer consistent with the one displayed on the monitor). After the value of the manometer stabilizes, select **Calibrate High**.
- 7 Select **Calibrate Main Sensor**.
- 8 Select **Calibrate Overpressure Unit**.
- 9 Exit **NIBP Calibration**. After the system is restarted, enter the **System** setup menu again and select **Pressure Verif**. Apply a fixed static pressure on the monitor with the help of the manometer. Check the displayed values on the monitor against the manometer configuration.
- 10 A tolerance of ± 3 mmHg is reasonable.

6.2 Maintenance of the Monitor

Keep the exterior surface of the monitor clean, free of dust and dirt.

The gathering of dew on the screen may occur with abrupt temperature or humidity changes. A stable environment is recommended.

Do not scratch or damage the screen.

Avoid high voltage and static charge.

6.3 Maintenance of the Transducers

Wipe off coupling gel from the ultrasound transducer after use to prolong its life.

Handle the transducers with care. Rough handling could damage the cover, piezoelectric crystals and mechanical parts. Contacting the transducers with hard or sharp objects should be avoided.

Do not excessively flex the cables.

6.4 Maintenance of the Recorder

The recorder platen, thermal print head and paper sensing mechanism must be cleaned at least once a year or when needed (when traces become faint).

To clean the recorder:

- 1) Clean the recorder platen with a lint-free cloth dampened in soap/water solution.
- 2) Wipe the thermal array using a cotton swab moistened with mild near neutral detergent, ethanol 75% or isopropanol 70% alcohol-based solution.
- 3) Remove the dust from the paper sensing mechanism and paper sensor with a dry clean cloth.

CAUTION

Only use the recorder paper provided by EDAN, or it may damage the recorder. This kind of damage is not covered by warranty.

Chapter 7 Principle Introduction

7.1 System Principle Block Diagram

F6 monitor consists of the main control board, fetal monitor (FM) module, DECG module, print board, power module, key board, LCD and the corresponding interface boards. Besides that, F6 Express includes X12 module and SpO₂ module. Here is the system principle block diagram:

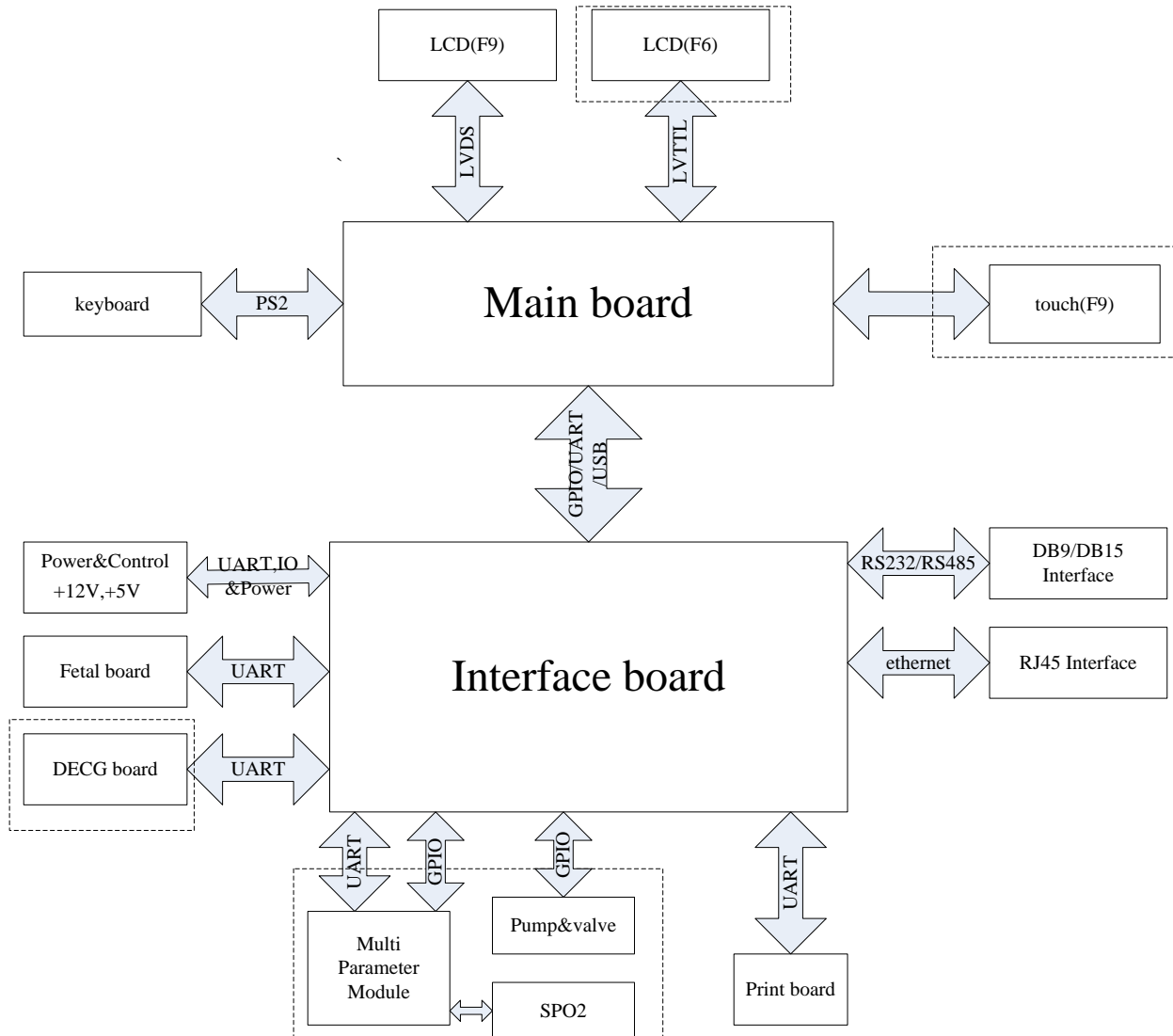

Figure 7-1 System principle block diagram

7.1.1 Main Control Board

The main control board applied is the ARM9 main control board. It fulfills the following function: key input control, LCD display, process print, audio alarm and led indicate light alarm, data memory and recall, time and date management, communication with the internal modules, ect.

The parameters of this main control board are listed below:

Power	5V, 12V
Processor	Kernel: ARM9 Work frequency: 400MHz External bus frequency: 133MHz Dictate Cache: 32K bytes Data Cache: 32K bytes
Net Port	10/100M Standard Ethernet port
EMS Memory	SDRAM: 128M byte Flash: program + data 32M bytes
Serial Port	10 serial port ways
USB	1 standard USB HOST interface, 1 standard DEVICE interface (1.1 specification)
VGA	1 VGA output port
LCD	1 TFT LCD interface, 1280*860 (highest resolution)
Keyboard	1 PS/2 keyboard interface
GPIO	At least 4
Watchdog Timer	1.6s
Power Consumption	700mA @ +5V (max)
Size	142 mm×105 mm
Operating System	Linux

7.1.2 Fetal Monitor Module

The main function of the fetal monitor module is to detect FHR, AFM and TOCO, and a new function of collecting and playing back audio signals is added. As shown in figure 3, power, simulating front circuit, ADC, audio processing circuit and digital circuit are included. Signal detecting is divided into three branches: two fetal hearts and fetal movements detecting and one for TOCO (pressure on the pregnant woman's abdomen) detecting.

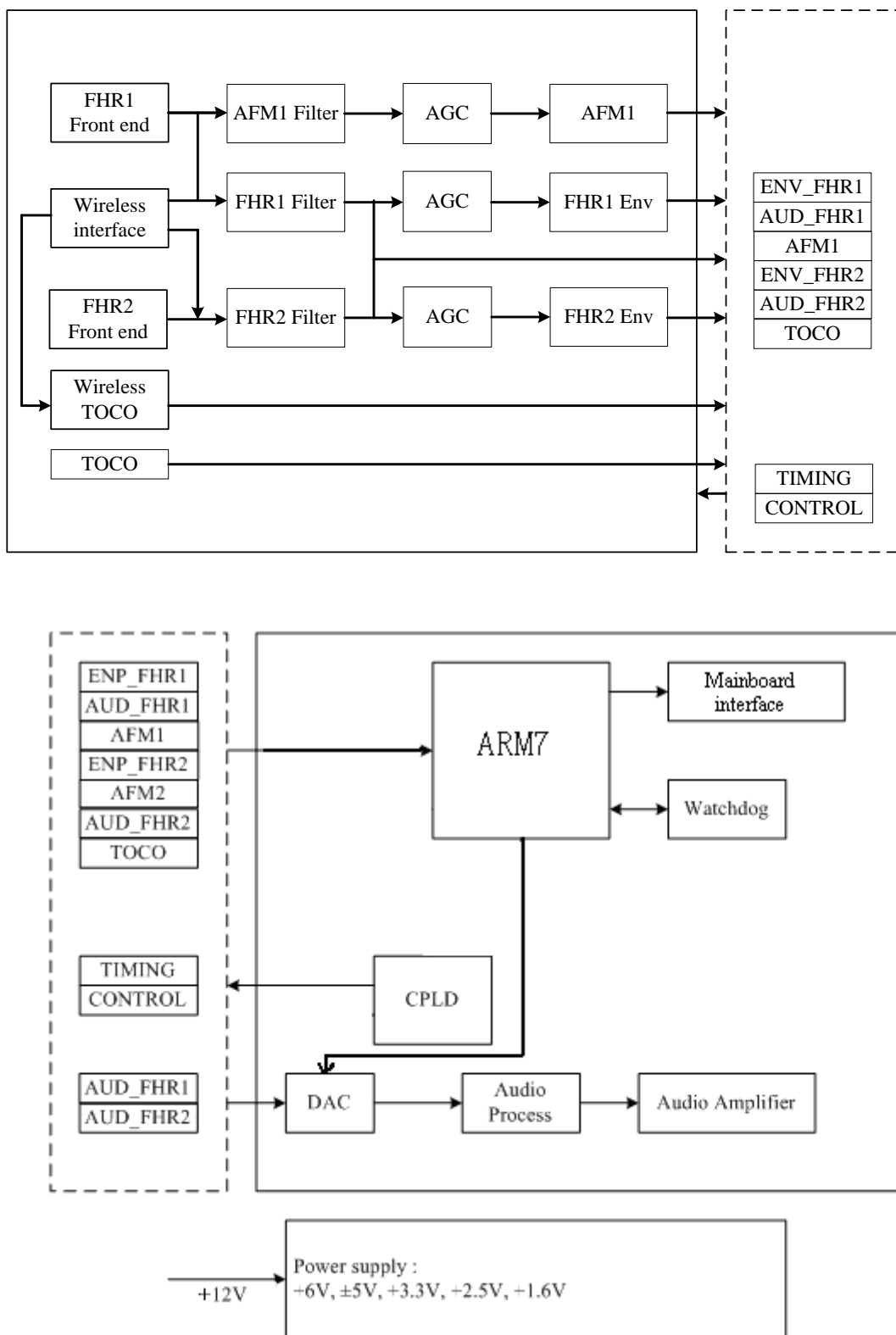

Figure 7-2 Fetal monitor module circuit block diagram

7.1.3 DECG Module

The DECG module fulfills the function of DECG detecting, TOCO and intrauterine pressure measuring, and then send the results to the main control board through serial port.

7.1.4 ECG Module

The ECG module includes ECG monitoring part and TEMP monitoring part. Their specifications are listed as follows:

(1) ECG

Lead Mode	3 Leads (R, L, F or RA, LA, LL),
Lead Selection	I, II, III, drive leads change accordingly
Waveform	1 channel
Measurement Range	30 bpm ~ 240 bpm
Accuracy	± 2 bpm
Resolution	1 bpm
Differential Input Impedance	≥ 5 MΩ
Defibrillator Protection	Yes
ESU Protection	None

(2) TEMP

Channel Qty.	1
Measurement Range	0 °C ~ +50.0 °C (+32°F ~ +122°F)
Resolution	0.1 °C (±0.18°F)
Accuracy (Sensor inaccuracy not included)	0°C ~ +25°C (+32°F ~ +77°F): ± 0.2°C (±0.36°F) +25°C ~ +45°C (+77°F ~ +113°F): ± 0.1°C (±0.18°F) +45°C ~ +50°C (+113°F ~ +122°F): ± 0.2°C (±0.36°F)
Sensor Type	YSI-10K
Refresh Time	Every 1 ~ 2 second(s)

7.1.5 NIBP Module

Method	Oscillometric
Mode	Manual: requires user to enable the measurement every single time Auto Circle: the system measures NIBP automatically and repeatedly according to the pre-set time interval. The first measurement needs to be enabled manually.
Auto Circle Mode Interval	1, 2, 3, 4, 5, 10, 15, 30, 60, 90, 120, 240, 480 minute(s)
Measuring Content	Systolic Pressure, Diastolic Pressure, Mean Artery Pressure
Range	Systolic Pressure Range: 40 mmHg ~ 270 mmHg Diastolic Pressure Range: 10 mmHg ~ 215 mmHg Mean Artery Pressure Range: 20 mmHg ~ 235 mmHg
Cuff Pressure Range	0 mmHg ~ 300 mmHg
Pressure Resolution	1 mmHg
Measurement Time Span	120 Seconds (Maximum)
Software Overpressure Protection	(297 ± 3) mmHg
Hardware Overpressure Protection	(320 ± 10)mmHg

7.1.6 SpO₂ (A8⁺) Module

The SpO₂ module consists of two parts: sensor and measuring system. The measuring system includes SpO₂ signals collecting, amplified simulating circuit system and relative digital/analog converting, and signal processing systems.

The pulse extent of optical signal changes during monitoring. SpO₂ parameter, pulse rate signal and pleth wave will be acquired after calculation. These data will be transmitted to the position machine with special communication protocol. The specifications are listed as follows:

SpO ₂	
Measurement Range	50% ~ 100%
Resolution	1%
Accuracy	90% ~ 100%: ± 2% 70% ~ 90%: ± 4% < 70%: Not Defined
Pulse	
Measurement Range	30 bpm ~ 240 bpm
Resolution	1 bpm
Accuracy	± 3 bpm

7.1.7 Print Controlling Board

The print controlling board is in charge of receiving data from main control board and driving the thermosensitive printhead to print. Its structure block diagram is as follows:

The print controlling board is in charge of receiving data from main control board and driving the thermosensitive printhead to print. Its structure block diagram is as follows:

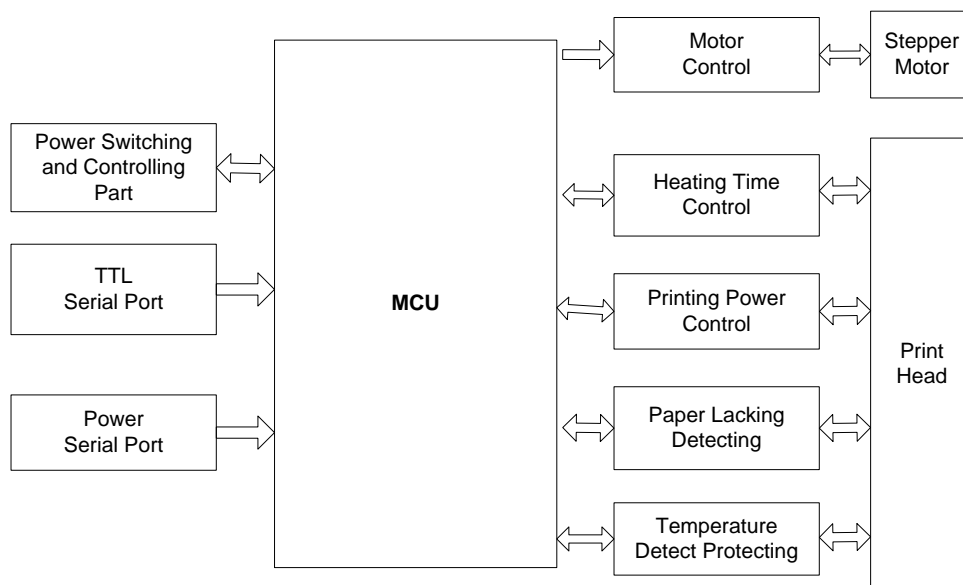
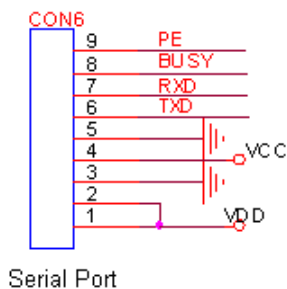

Figure 7-3 Print controlling board principle block diagram

The recorder module includes: microprocessor AT91SAM7S256 circuit, power switch and control, communicate interface, motor control part, recorder paper detecting circuit, time control for printing power and heating, paper lacking temperature control and thermosensitive head protecting circuit.

Definitions of print controlling board interfaces

(1) Interface connects to bottom interface board



Pin No.	Symbol
1	VDD
2	VDD
3	GND
4	VCC
5	GND
6	TXD
7	RXD
8	BUSY
9	PE

(2) Interface connects to print head

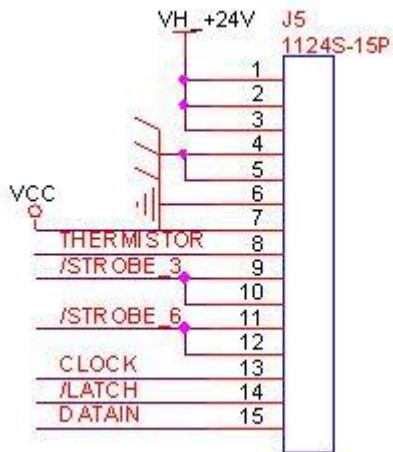

Pin No.	Symbol
1	VH_+24V
2	VH_+24V
3	VH_+24V
4	GND
5	GND
6	GND
7	VCC
8	THERMISTOR
9	/STROBE_3
10	/STROBE_3
11	/STROBE_6
12	/STROBE_6
13	CLOCK
14	/LATCH
15	DATAIN

(3) Interface connects to stepper motor (gear assembly)

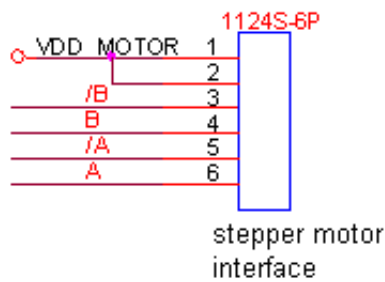

Pin No.	Symbol
1	VDD_MOTOR
2	VDD_MOTOR
3	/B
4	B
5	/A
6	A

(4) Interface connects to paper sensor (paper lack detecting)

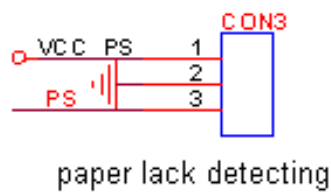

Pin No.	Symbol
1	VDD_PS
2	GND
3	PS

7.1.8 Power Interface Board

The power interface board is used to transfer the power, its circuit is:

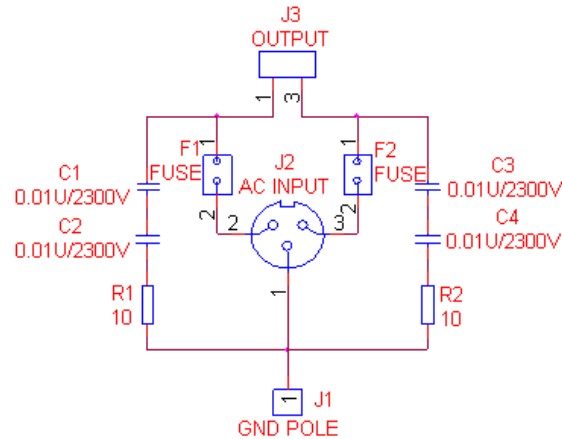

Figure 7-4 Power Interface board circuit

F1 and F2 are two containers for fuses, the specification of the fuse is: T2AH250V.

J1 is the equipotential grounding point that connects to the ground.

J2 is a 3-pin socket for outer power input.

J3 is the output port connecting to the power module in the machine.

C1, C2, C3 and C4 are Y capacitors, every capacitor resists 2300V voltage. Connecting a 10 Ω resistor and two Y capacitors in series between L-PE and N-PE will improve the fetal heart and solve the data jumping problem when measuring FH with EFT.

When laying out the PCB of this board, the creepage distances between L, N and PE must not be less than 8mm, the distance between L and N must not be less than 3mm.

7.1.9 Power Module

The power module outputs +12V, +5V voltage and manages charging.

When outer power (90-264VAC) is connected, the power module converts the alternative current into 12V and 5V direct current, providing power for monitor running and built-in battery charging. When outer power is disconnected, the power module converts the battery power into 12V and 5V direct current, providing power for monitor running.

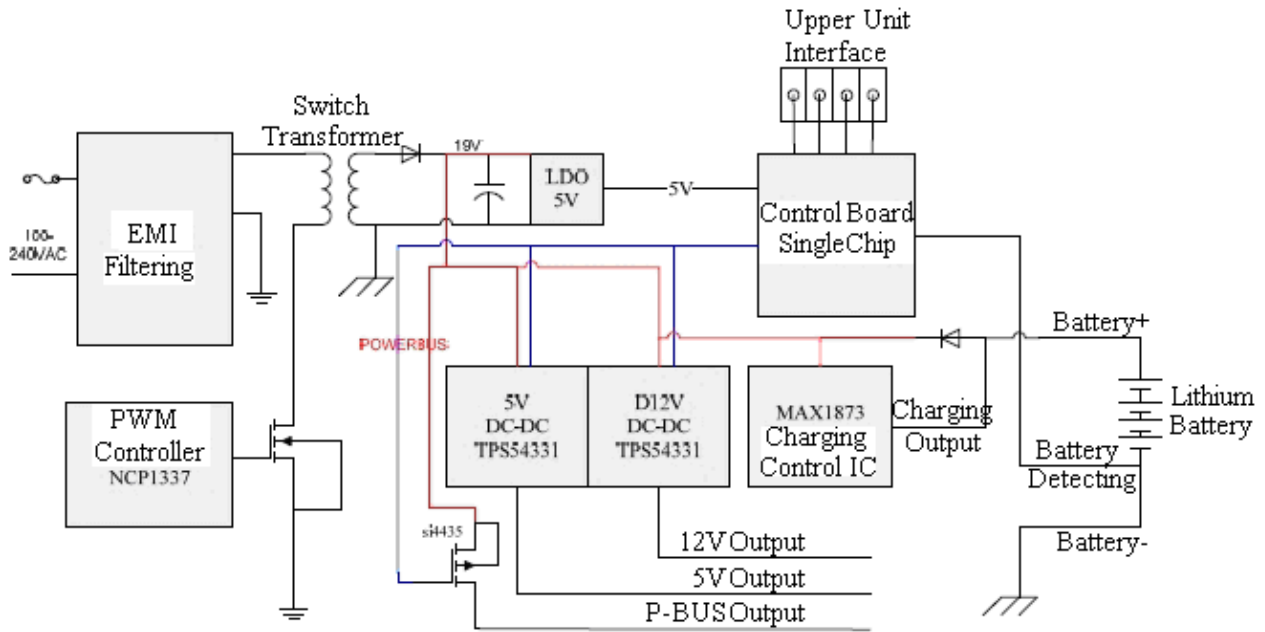

Figure 7-5 Power module block diagram

7.1.10 Key Board

The key board codes the operation of keys and control knob with singlechip processor, sends keycode to main control board using PS2 protocol, answers the corresponding keys and controls display of power indicator, AC indicator and Charge indicator. Its structure block diagram is as follows:

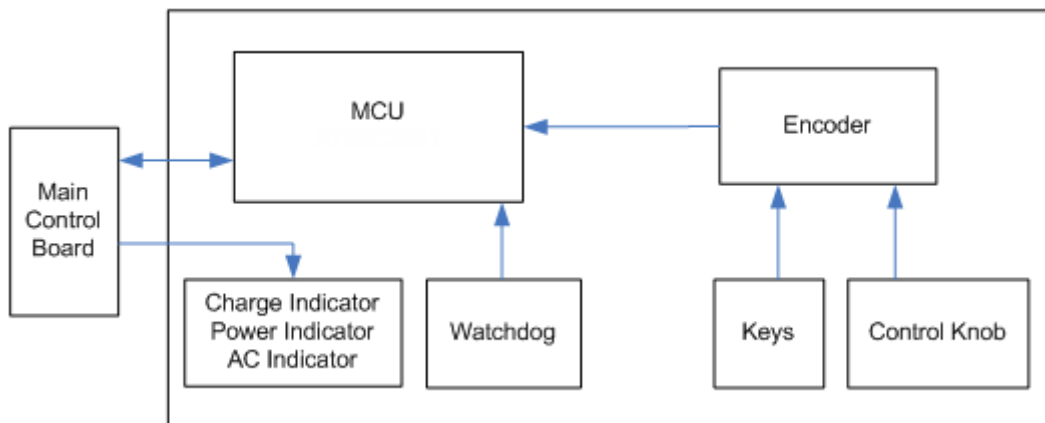

Figure 7-6 Key board principle block diagram

7.1.11 Interfaces Board

The bottom interface board consists of connect CNS interconnection circuit, voltage switching circuit, built-in wireless module power circuit and interfaces.

Interface definition

(1) Interface connects to power module

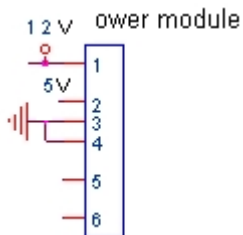

Pin No.	Symbol
1	+12V
2	+5V
3	GND
4	GND
5	/
6	/

(2) Interface connects to power control board

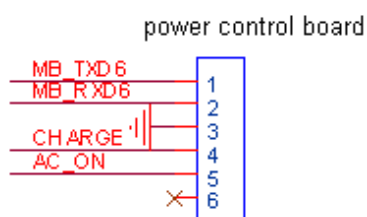

Pin No.	Symbol
1	MB_TXD6
2	MB_RXD6
3	GND
4	CHARGE
5	AC_ON
6	Reserved

(3) Interface connects to FM board

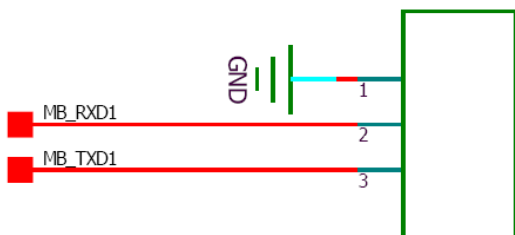

Pin No.	Symbol
1	GND
2	MB_RXD1
3	MB_TXD1

(4) Interface connects to print controlling board

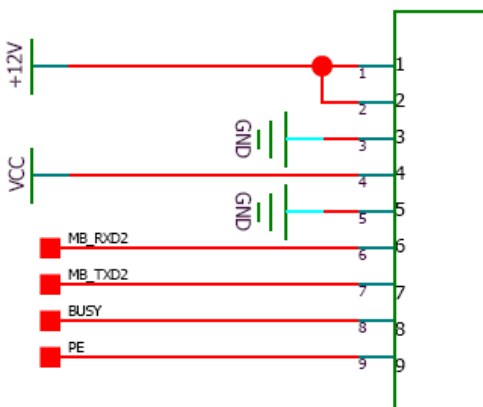

Pin No.	Symbol
1	+12V
2	+12V
3	GND
4	VCC
5	GND
6	MB_RXD2
7	MB_TXD2
8	BUSY
9	PE

(5) Interface connects to main control board

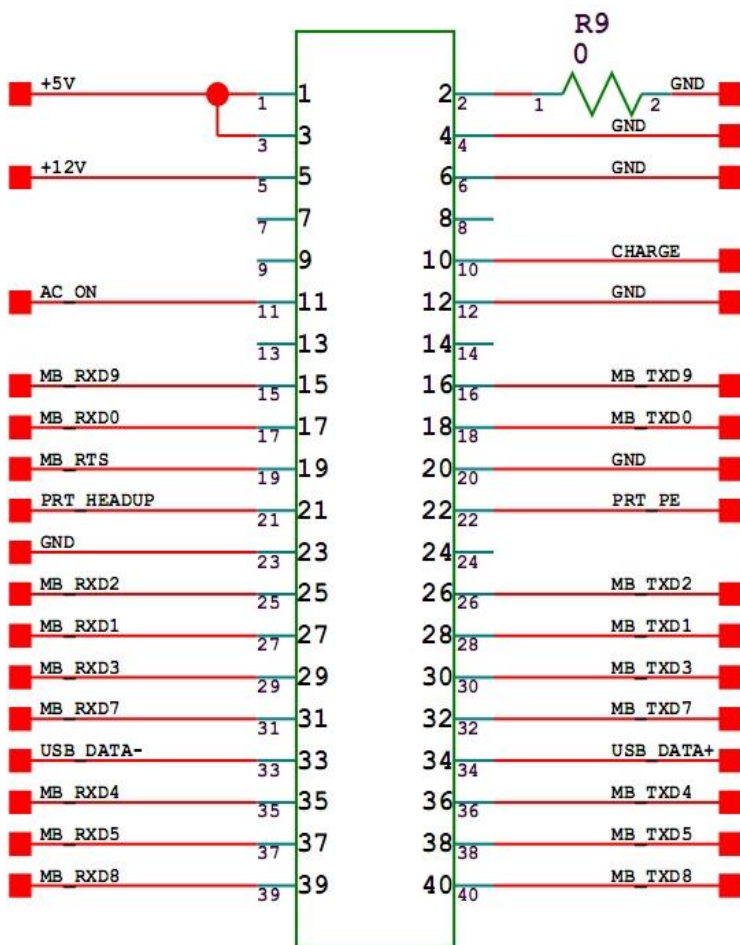

Pin NO.	Symbol	Pin NO.	Symbol
1	+5V	2	GND
3	+5V	4	GND
5	+12V	6	GND
7	/	8	/
9	/	10	CHARGE
11	AC_ON	12	GND
13	/	14	/
15	MB_RXD9	16	MB_TXD9
17	MB_RXD0	18	MB_TXD0
19	MB_RTS	20	GND
21	PRT_HEADUP	22	PRT_PE
23	GND	24	/
25	MB_RXD2	26	MB_TXD2
27	MB_RXD1	28	MB_TXD1
29	MB_RXD3	30	MB_TXD3
31	MB_RXD7	32	MB_TXD7
33	USB_DATA-	34	USB_DATA+
35	MB_RXD4	36	MB_TXD4
37	MB_RXD5	38	MB_TXD5
39	MB_RXD8	40	MB_TXD8

(6) Interface connects to DECG module

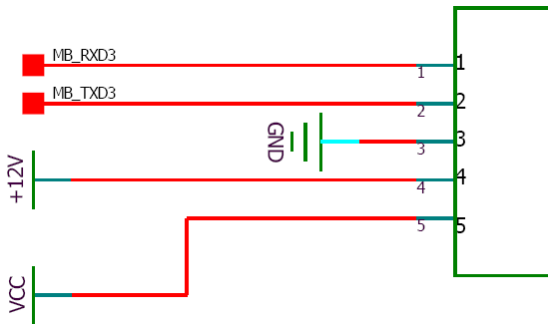

Pin No.	Symbol
1	MB_RXD3
2	MB_TXD3
3	GND
4	+12V
5	VCC

(7) RJ45 Ethernet interface

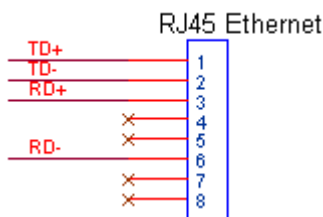

Pin No.	Symbol
1	TD+
2	TD-
3	RD+
4	Reserved
5	Reserved
6	RD-
7	Reserved
8	Reserved

(8) USB interface

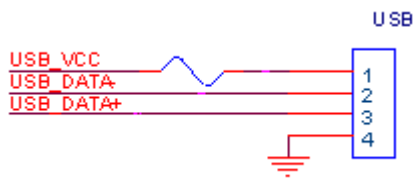

Pin No.	Symbol
1	USB_VCC
2	USB_DATA-
3	USB_DATA+
4	GND

(9) RS232 (485 network) interface

D-Sub interface:

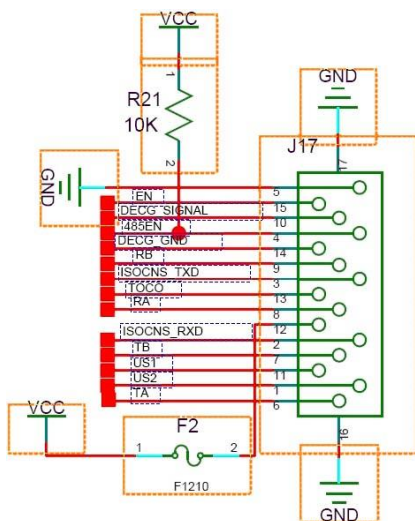

Pin No.	Symbol
1	US2
2	ISOCNS_RXD
3	ISOCNS_TXD
4	485EN
5	0V Ref.
6	TA
7	TB
8	RA
9	RB
10	DECG_SIGNAL
11	US1
12	+5V
13	TOCO

DB9 interface:

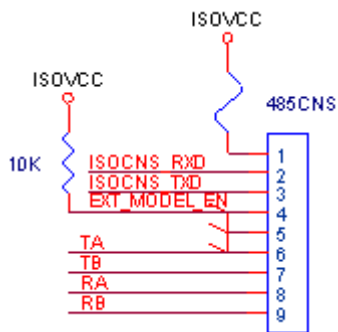

Pin No.	Symbol
1	ISOVCC
2	ISOCNS_RXD
3	ISOCNS_TXD
4	EXT_MODEL_EN
5	GND
6	TA
7	TB
8	RA
9	RB

(10) Interface connects to built-in wireless module

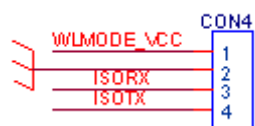

Pin No.	Symbol
1	WLMODE_VCC
2	GND
3	ISORX
4	ISOTX

(11) Ethernet interface

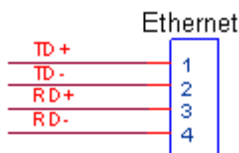

Pin No.	Symbol
1	TD+
2	TD-
3	RD+
4	RD-

7.1.12 LVDS LCD

F6 applies a 10.1” LCD screen. Its main technical specifications are as follows:

Items	Specifications
LCD size	10.1 inch (Diagonal)
Drive element	a-Si TFT active matrix
Resolution	800 x 3 (RGB) x 480
Display Mode	Normally White, Transmissive
Dot pitch	0.0925mm (W) x 0.276mm (H)
Active area	222.0mm (W) x 132.48mm (H)
Module size	235.0mm (W) x 145.8mm (H) x 6.1mm (D)
Surface treatment	Anti-Glare
Color arrangement	RGB-stripe
Interface	Digital
Backlight power consumption	4.098W(Typ.)
Panel power consumption	250mW(Typ.)
Weight	(332±10%) g

7.1.13 LCD Backlight Board

The LCD backlight board provides backlight for LCD, and the voltage is 12VDC.

7.1.14 LCD Driving Board

The LCD adopted is an analogue/digital mixed LCD, who requires complicated sequence and voltage. The LCD driving board is intended for providing the necessary sequence and voltage signals.

Its structure block diagram is shown as follow:

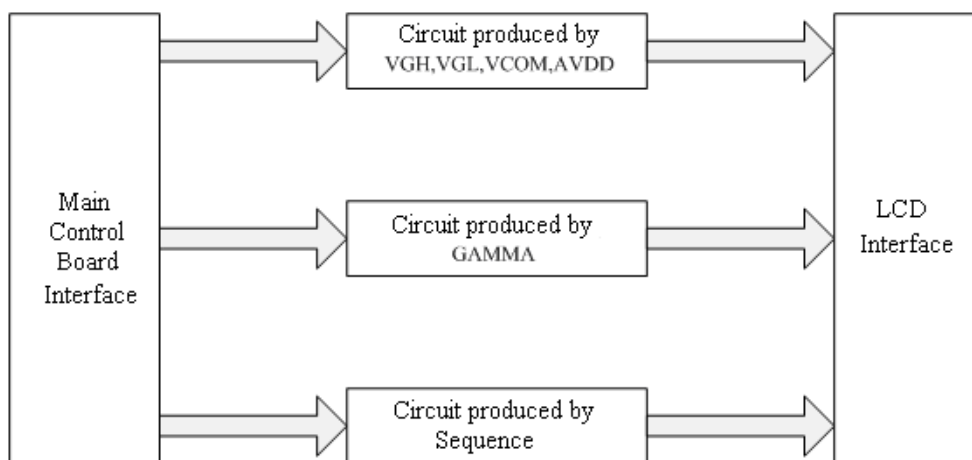

Figure 7-7 LCD Driving Board Block Diagrame

7.2 Interfaces

On the rear panel of the monitor, there are two interfaces and an antenna:

- DB9 interface or D-Sub interface
- RJ45 interface (NETWORK)
- Antenna

7.2.1 DB9/D-Sub Interface

All the monitors are configured with a DB9 interface or D-Sub interface.

It is used to connect the monitor to a computer for monitoring information collection (with a software such as Insight.), or to an obstetrical monitoring system such as MFM-CNS.

7.2.2 RJ45 Interface

All the monitors are configured with an RJ45 interface.

It is used to connect the monitor to a computer for updating or monitoring information collection (with software such as Insight.), or to an obstetrical monitoring system such as MFM-CNS.

7.2.3 Antenna

If the monitor has a built-in wireless module, an antenna will be configured.

It is used to send signals of the bedside monitor to the obstetrical monitoring system.

Chapter 8 Troubleshooting

This troubleshooting guide introduces the suitable actions for correcting the problems or replacing the accessory or calling the service person. It can also help you to have more exact descriptions of the fault symptoms when calling for service.

EDAN supports replacement of PCBs and major subassemblies for this product. Verify the malfunction of the PCBAs/Modules prior to disassembling with the method described in chapter 9 *Modules' Malfunction Verification*. When replacement is needed, follow the procedures described in chapter 10 *Disassembling the Monitor*.

8.1 Monitor Booting Failures

Phenomenon	Possible Cause	Solution
After switching on, LCD has no display; the power indicator is off; the fan doesn't run.	No AC mains connected.	Check if the power cord is damaged. Check if the power cord is well connected to the power socket of the monitor and hospital AC outlet.
	The fuses are blown.	Replace the fuses.
	Main control board defective.	Replace the main control board.
The fuses blow when switching on the monitor.	Power board defective.	Replace the power board.
	Short circuit of other parts	Look for the short circuit source and fix it.
Abrupt switching off.	The monitor is stricken by strong high voltage, such as lighting strike.	Check the power supply and earth system.
	Bad power supply performance.	Replace power supply.
	Main control board defective.	Replace the main control board.
	Bad connection.	Check all the connectors.

8.2 Display Failures

Phenomenon	Possible Cause	Solution
The LCD has no display.	The LCD related cable(s) is (are) disconnected.	Check that the LCD related cables between the main control board and the LCD are well connected. Check that the LCD backlight cable is well connected.
	LCD defective.	Replace the LCD.
	LCD backlight board defective.	Replace the LCD backlight board.
	Main control board defective.	Replace the main control board.
LCD displays improper characters.	LCD defective.	Replace the LCD.

8.3 Operation Failures

Phenomenon	Possible Cause	Solution
Keys not functioning	Bad key board connection.	Check key board wire.
	Key board is damaged.	Replace the key board.
When a key is pressed, no tone is heard.	Loudspeaker or wire has a failure.	Replace the loudspeaker or the wire.
Hoarse or odd sound from loudspeaker.	Loudspeaker defective.	Replace the loudspeaker.
	Main control board defective.	Replace the main control board.

8.4 Recorder Failures

Phenomenon	Possible Cause	Solution
No paper advances.	No paper in the drawer.	Load paper and close the drawer.
	Paper drawer is open.	Close the drawer.
	Paper jam.	Open the drawer and remove the paper jam. Re-load paper then close the drawer.
	Print controlling board defective.	Replace the print controlling board.

	Recorder connection failure.	Check all the connectors.
	Gear assembly defective.	Replace the gear assembly.
	Main control board defective.	Replace the main control board.
The “Check paper” alarm message appeared on the screen, but the drawer is not empty.	Paper sensor dirty.	Clean the paper sensor with a dry clean cloth.
	Paper sensor defective.	Replace the paper sensor.
	The paper drawer is not closed properly.	Push the drawer back in position.
Blank, blurry or incorrect traces.	Paper is not correctly loaded.	Reload paper correctly.
	The printhead adjusting nuts are lopsided.	Adjust the printhead adjusting nuts.
	Print head defective.	Replace the printhead.
	Improper paper settings of the monitor.	Set paper style according to section 5.11 <i>Changing Paper Style</i> .

8.5 Network Failures

Phenomenon	Possible Cause	Solution
The monitor can not connect to a network.	The RS232 or Ethernet socket defective.	Replace the RS232 or Ethernet socket.
	Bad connection between the bottom interface board and main control board.	Check the connection.
	Main control board defective.	Replace main control board.
	Overlapped device no. in the network.	Change device no. of the monitor.
	Incorrect sever IP setting.	Set server IP correctly.

8.6 Alarm Failures

Phenomenon	Possible Cause	Solution
No audible alarm is activated.	The audible alarm is temporarily disabled.	Switch on the audible alarm.
	Loudspeaker or wire defective.	Replace the loudspeaker or the wire.

The alarm indicator stays off.	Alarm indicator board defective.	Replace alarm indicator board.
No audible alarm or visual alarm is activated.	Program defective.	Update the software.

8.7 Technique Alarms

Phenomenon	Possible Cause	Solution
Fetus EQUIP MALF	Bad connection between FM module, bottom interface board and main control board.	Check the connection.
	FM module defective.	Replace FM module.
	Main control board defective.	Replace main control board.
DECG EQUIP MALF	Bad connection between DECG module, bottom interface board and main control board.	Check the connection.
	DECG board defective.	Replace DECG board.
	Main control board defective.	Replace main control board.
NIBP EQUIP MALF	Bad connection between NIBP module, bottom interface board and main control board.	Check the connection.
	NIBP board defective.	Replace X12 board.
	Main control board defective.	Replace main control board.
ECG EQUIP MALF	Bad connection between ECG module, bottom interface board and main control board.	Check the connection.
	ECG board defective.	Replace X12 board.
	Main control board defective.	Replace main control board.
SpO ₂ EQUIP MALF	Bad connection between SpO ₂ module, bottom interface board and main control board.	Check the connection.
	SpO ₂ board defective.	Replace X12 board or A8 ⁺ board.
	Main control board defective.	Replace main control board.

8.8 FHR/TOCO Monitoring Failures

Phenomenon	Possible Cause	Solution
No FHR/TOCO trace or numeric value.	Bad connection of the transducers.	Check the connection.
	US Transducer defective.	Replace the transducer.
	FM module defective.	Replace the FM module.
	Main control board defective.	Replace the main control board.
Lower heart beat or no sound.	Loudspeaker defective.	Replace the loudspeaker.
	US transducer defective.	Replace the US transducer.
	Main control board defective.	Replace the main control board.
Inaccurate measurement values.	FM module defective.	Replace the FM module.
	Main control board defective.	Replace the main control board.

8.9 DECG/IUP Monitoring Failures

Phenomenon	Possible Cause	Solution
No DECG/IUP trace or numeric value.	Bad connection of cables.	Check the connection.
	Cables defective.	Replace the cables.
	DECG module defective.	Replace the DECG module.
	Main control board defective.	Replace the main control board.

8.10 ECG Monitoring Failures

Phenomenon	Possible Cause	Solution
No ECG trace.	Bad connection of ECG cable.	Check the connection.
	Cables defective.	Replace the cables.
	Bad connection of electrodes.	Check the connection.
	ECG module defective.	Replace the X12 board.
	Main control board defective.	Replace the main control board.

8.11 SpO₂ Monitoring Failures

Phenomenon	Possible Cause	Solution
No SpO ₂ waveform or numeric value.	SpO ₂ transducer defective.	Replace the SpO ₂ transducer.
	Bad connection of SpO ₂ cable.	Check the connection.
	Cables defective.	Replace the cables.
	SpO ₂ module defective.	Replace the X12 board or A8 ⁺ board.
	Main control board defective.	Replace the main control board.

8.12 NIBP Monitoring Failures

Phenomenon	Possible Cause	Solution
The cuff fails to be inflated.	Bad connection of the cuff, the air hose and the NIBP socket.	Check the connection from outside.
	Bad connection of the NIBP module to the NIBP socket.	Check the connection from inside.
	Cuff or extension tube defective.	Replace the damaged part(s).
	Air pump, air valve leak.	Replace pump valve module.
	NIBP module defective.	Replace the X12 module.
	Main control board defective.	Replace the main control board.
No NIBP numeric values.	NIBP module defective.	Replace the X12 module.
	Air pump, air valve leak.	Replace pump valve module.
	Main control board defective.	Replace the main control board.

8.13 TEMP Monitoring Failures

Phenomenon	Possible Cause	Solution
No TEMP numeric value.	TEMP transducer defective.	Replace the TEMP transducer.
	Bad connection of TEMP transducer.	Check the connection.
	ECG module defective.	Replace the X12 module.
	Main control board defective.	Replace the main control board.

Chapter 9 Modules' Malfunction Verification

When a module is suspected of malfunction, verify it with the method described in this chapter.

NOTE: For all the interfaces, the first pin is the one with a square solder pad.

9.1 Verifying Malfunction of the Main Control Board

To verify the main control board,

- 1) Open the main unit using the procedures described in section 10.3.
- 2) Switch on the monitor. (Powered by AC or battery.)
- 3) Measure the voltage to earth of the pins listed below, using a multimeter:

Item	Reference Pin	Test Pin	Reference Result
①	TP58(GND)	TP52	11.4~12.6V
②	TP58(GND)	TP56	4.75~5.25V
③	TP58(GND)	TP53	3.14~3.46V
④	TP58(GND)	TP54	2.38~2.62V
⑤	TP58(GND)	TP51	1.65~1.95V
⑥	TP58(GND)	TP55	1.14~1.26V
⑦	TP58(GND)	TP50	0.90~1.10V
⑧	TP58(GND)	TP61	0.90~1.10V

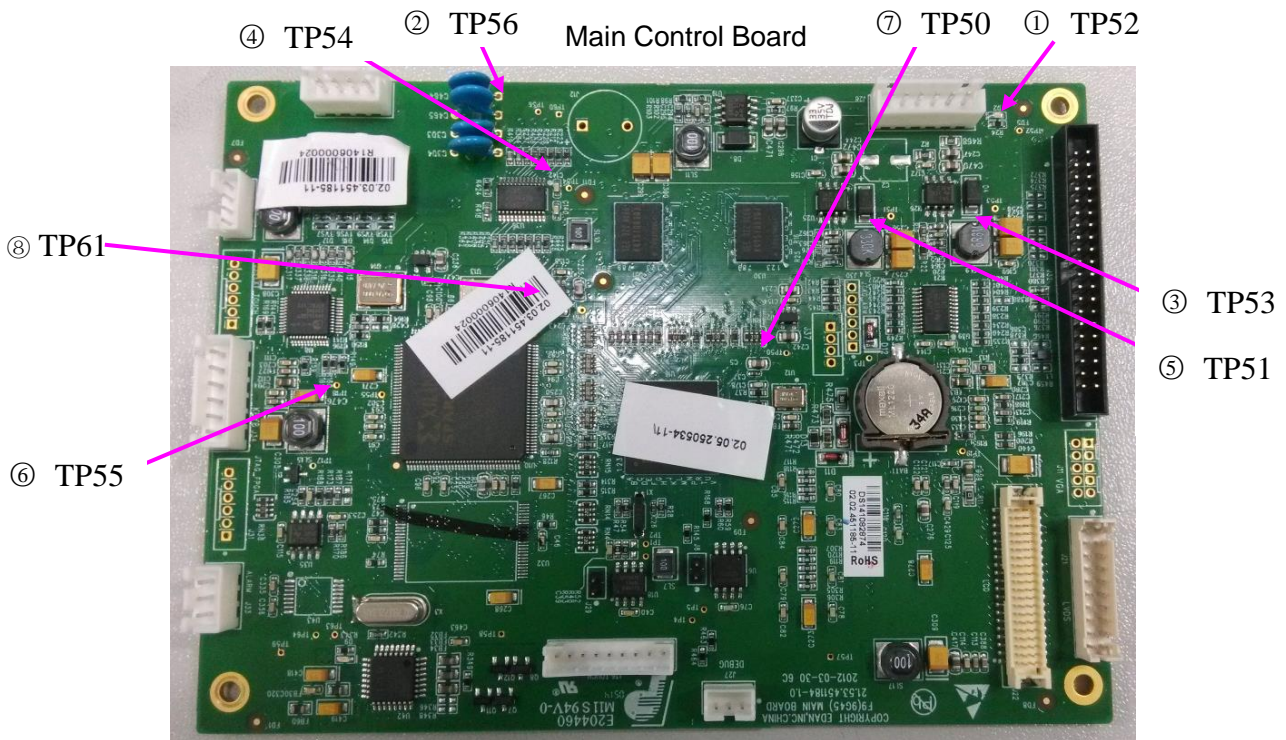

Back of the Main control board

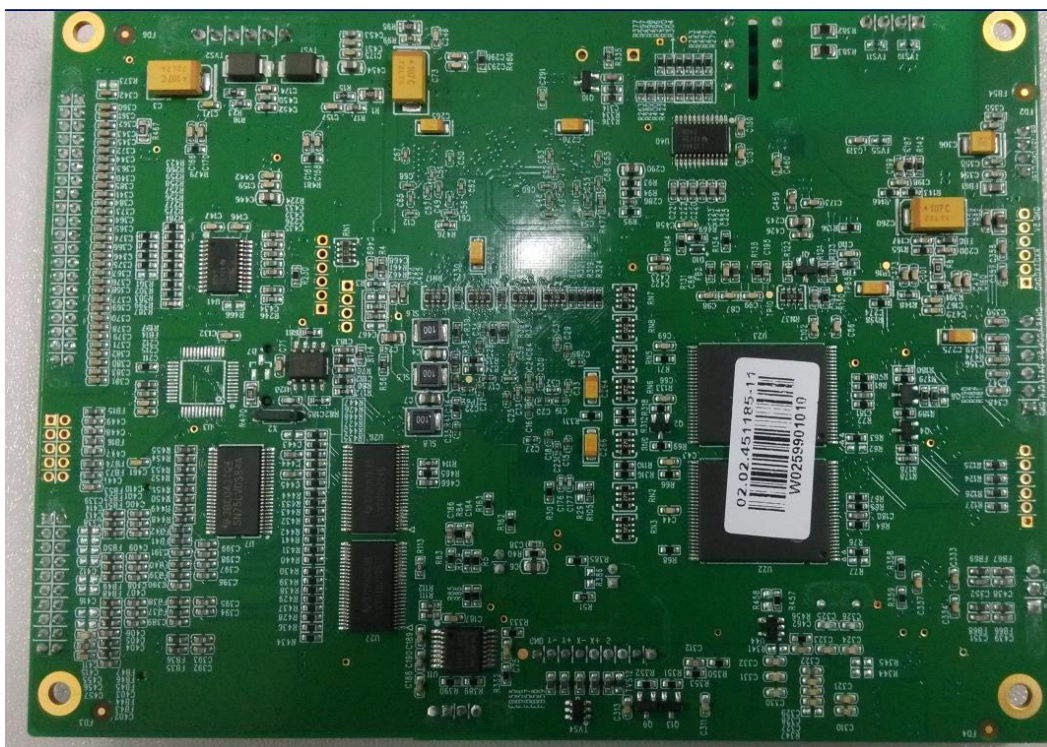

- 4) Compare the measurement results with the reference results in the list. If any one of the results exceeds the reference range, the main control board deflection is confirmed. Replacement of the main control board is recommended.

9.2 Verifying Malfunction of the FM Module

To verify the FM module,

- 1) Open the main unit using the procedures described in section 10.3.
- 2) Measure the voltage to earth of the pins listed below, using a multimeter; compare the measurement results with the reference results in the list. If all the results are in the allowance range. Switch on the monitor and measure the voltage to earth of the pins listed below.

Item	Pin	Reference result
①	TP6	(+6.8±10%) V
②	TP3	(+5±10%) V
③	TP10	(+2.5±10%) V
④	TP15	(+3.3±10%) V
⑤	TP2	(+1.67±10%) V
⑥	TP5	(+1.67±10%) V

⑦	TP4	(+2.5±10%) V
⑧	TP8	(+2.5±10%) V
⑨	TP9	(+2.5±10%) V
⑩	TP1	(+0.8±25%) V

FM Module

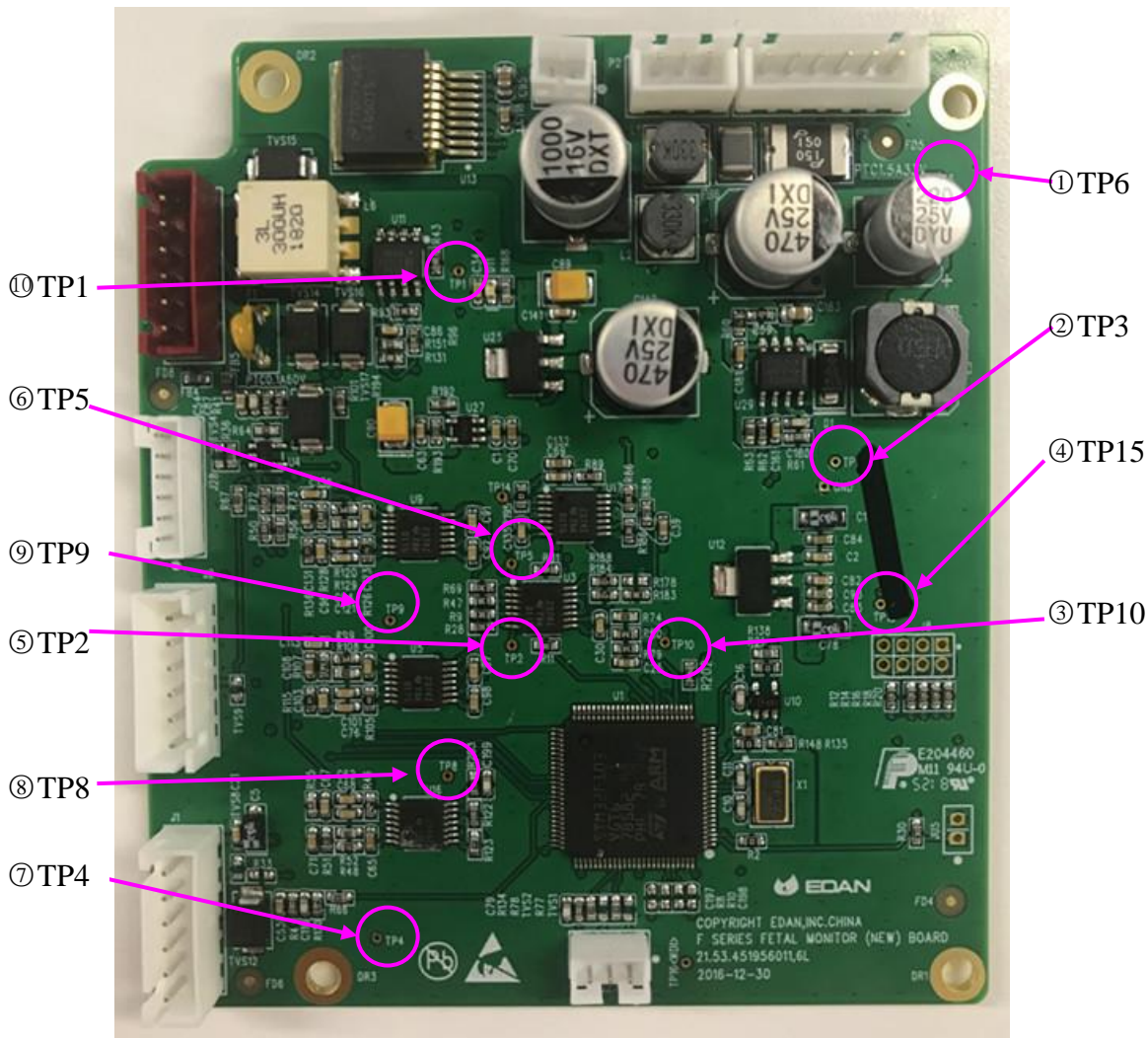

3) If any one of the results exceeds the reference range, the FM module deflection is confirmed. Replacement of the module is recommended.

9.3 Verifying Malfunction of the Power Module

To verify the power module,

- 1) Open the main unit using the procedures described in section 10.3.
- 2) Switch on the monitor.
- 3) Measure the voltage to earth of the following pins on the bottom interface board, using a multimeter: (Refer to section 9.3 for J3's location.)

Item	Reference Pin	Test Pin	Reference result
①	4 th pin of J3	1 st pin of J3	11.4~12.6 V
②	4 th pin of J3	2 nd pin of J3	4.75~5.25 V

- 4) If any one of the results exceeds the reference range, the power module deflection is confirmed. Replacement of the module is recommended.

9.4 Verifying Malfunction of the Main Parameter Module

To verify the main parameter module,

- 1) Open the main unit using the procedures described in section 10.3.
- 2) Switch on the monitor.
- 3) Measure the voltage to earth of the pins listed below, using a multimeter:

Item	Reference Pin	Test Pin	Reference Result
①	DR7	TP1	4.75~5.25V
②	DR7	TP2	11.4~12.6V
③	DR7	TP9	4.75~5.25V
④	DR7	TP10	4.75~5.25V
⑤	DR7	TP11	5.32~5.88V

Main Parameter Module Board

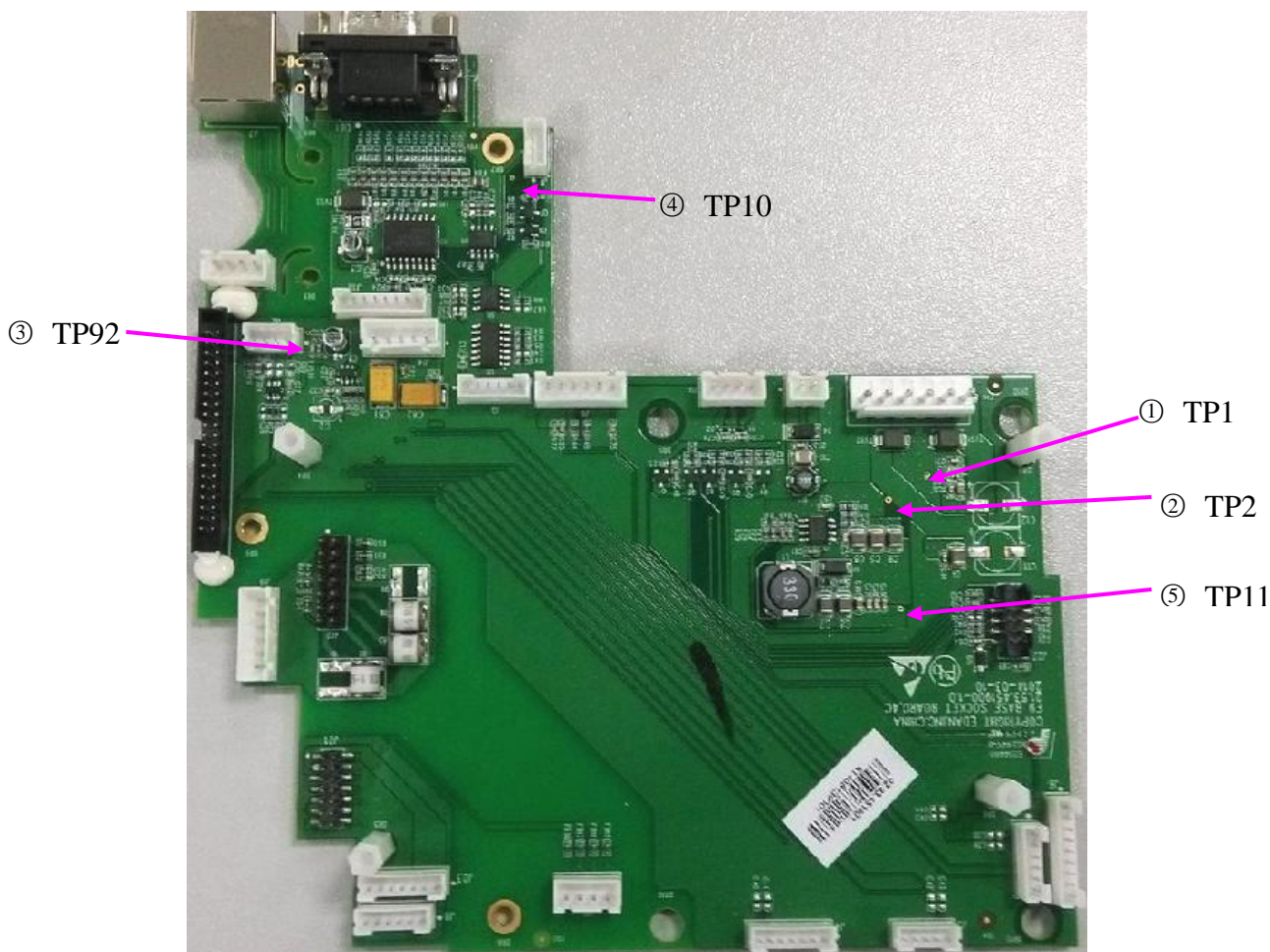

4) If any one of the results exceeds the reference range, the main parameter module deflection is confirmed. Replacement of the module is recommended.

9.5 Verifying Malfunction of the Multi-Parameter Module

To verify the multi-parameter module,

- 1) Open the main unit using the procedures described in section 10.3.
- 2) Switch on the monitor.
- 3) Measure the voltage to earth of the pins listed below, using a multimeter:

Item	Reference Pin	Test Pin	Reference Result
①	DR6(GND)	TP23 (VPP+5V)	4.75~5.25
②	6 th pin of J8 (DGND)	TP18 (VCC)	4.75~5.25
③	6 th pin of J8 (DGND)	TP20 (VDD)	3.14~3.46
④	6 th pin of J8 (DGND)	TP21 (DVCC)	4.75~5.25
⑤	6 th pin of J8 (DGND)	TP22 (DVDD)	3.14~3.46
⑥	6 th pin of J8 (DGND)	TP17 (AD78H-VREF)	3.84~4.24
⑦	6 th pin of J4 (FGND)	TP5 (AVCC)	4.75~5.25
⑧	6 th pin of J4 (FGND)	TP14 (AVCC_RESP)	4.75~5.25
⑨	6 th pin of J4 (FGND)	TP6 (F+2V5)	2.38~2.62

⑩	6 th pin of J4 (FGND)	TP9 (F-2V5)	-2.62~-2.38
⑪	6 th pin of J4 (FGND)	TP8 (AVSS)	-5.25~-4.75
⑫	6 th pin of J4 (FGND)	TP7 (F+3V3)	3.14~3.46
⑬	6 th pin of J4 (FGND)	TP10 (V+)	1.38~1.59
⑭	6 th pin of J4 (FGND)	TP11 (V-)	-1.76~-1.22
⑮	6 th pin of J4 (FGND)	TP12 (V+ RESP)	2.00~4.50
⑯	6 th pin of J4 (FGND)	TP13 (V- RESP)	-4.50~-2.00
⑰	6 th pin of J4 (FGND)	TP3 (VREFF)	1.46~1.62
⑱	6 th pin of J4 (FGND)	TP24 (RESP_VBIAS)	1.98V~2.18V

Multi-Parameter Module Board



- 4) If any one of the results exceeds the reference range, the multi-parameter module deflection is confirmed. Replacement of the module is recommended.

9.6 Verifying Malfunction of the Print Controlling Module

To verify the print controlling module,

- 1) Open the main unit using the procedures described in section 10.3.
- 2) Switch on the monitor.
- 3) Measure the voltage to earth of the pins listed below, using a multimeter:

Item	Pin	Reference Result
①	TP10	3.135V~3.465 V
②	TP13	21.6V~26.4V
③	TP18	3.135V~3.465 V

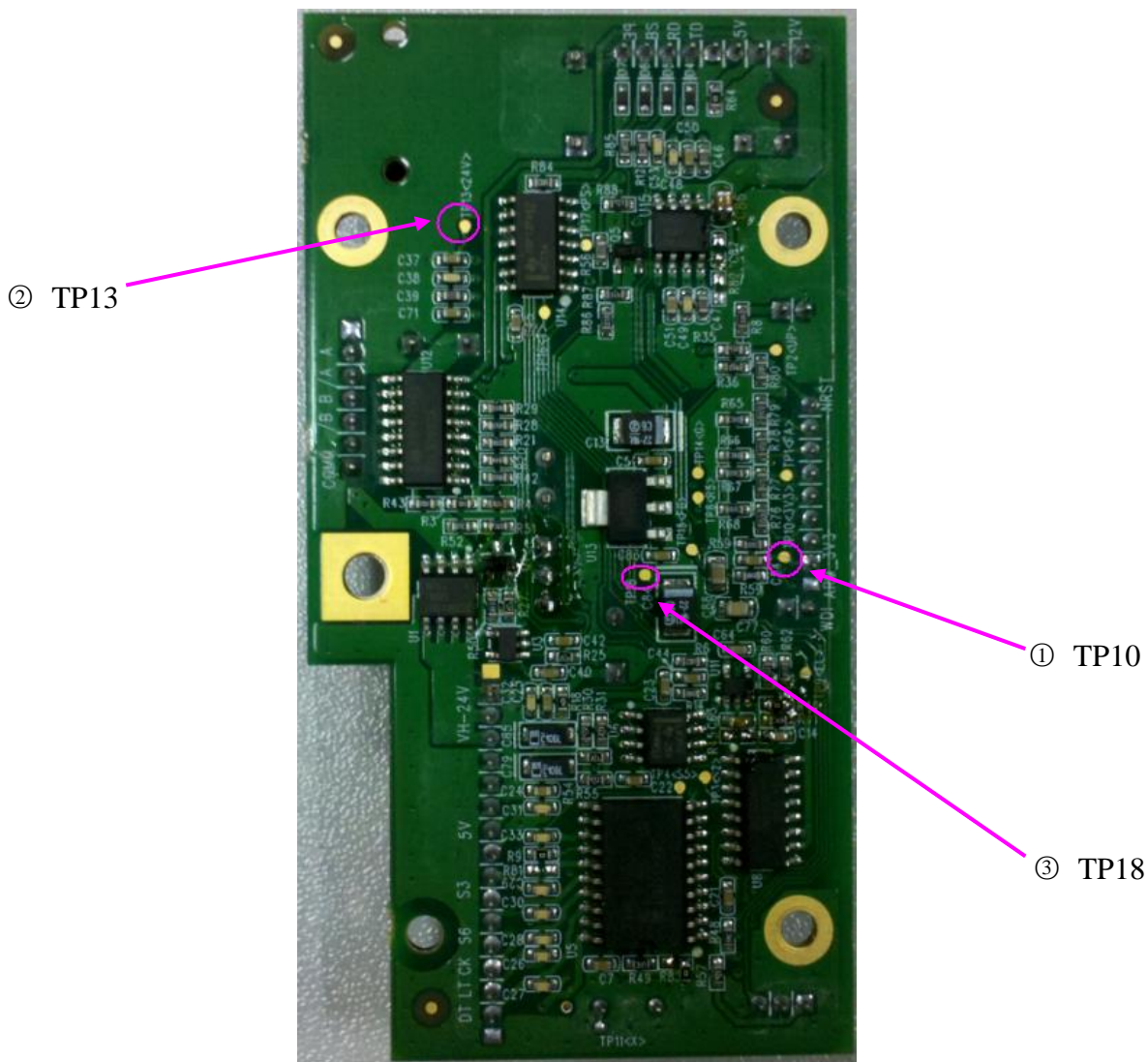

4) If any one of the results exceeds the reference range, the print controlling module deflection is confirmed. Replacement of the module is recommended.

9.7 Verifying Malfunction of the DECG Module

To verify the DECG module,

- 1) Open the main unit using the procedures described in section 10.3.
- 2) Switch on the monitor.
- 3) Measure the voltage to earth of the pins listed below, using a multimeter:

Item	Pin	Reference Result
①	TP5	2.375V~2.625 V
②	TP7	2.375V~2.625 V
③	TP8	3.135V~3.465 V
④	TP9	3.135V~3.465 V
⑤	TP10	-2.375V~ -2.625 V



4) If any one of the results exceeds the reference range, the DECG module defection is confirmed. Replacement of the module is recommended.

Chapter 10 Disassembling the Monitor

WARNING

- 1 Only qualified service personnel should open the monitor case.
- 2 Switch off the monitor and remove the AC power cable before disassembling the monitor.
- 3 After any repair of the monitor, perform safety tests before using the monitor again.

10.1 Tools Required

- 1 – A cross-head screwdriver
- 2 – A flat-head screwdriver
- 3 – A M3 nut driver
- 4 – A pair of pliers



10.2 Replacing Fuses

To replace the blown fuse,

- 1) Switch off the monitor and unplug it.
- 2) Fold the LCD display completely flat.
- 3) Carefully place the monitor upside down on a flat surface covered with cloth or other protecting pad.
- 4) Place a flat-head screw driver in the gap of the fuse. Apply a certain amount of pressure on the screw driver to sink the fuse for about 1 mm. Unscrew the fuse anticlockwise.



- 5) Remove the old fuse. Take out a new fuse supplied by EDAN or of the same specification:
Size: $\Phi 5\text{mm} \times 20\text{mm}$; Model: T2AH250V.
- 6) Place the new fuse in the fuse socket. Press it in and screw it clockwise back in position.

10.3 Disassembling the Main Unit

The main unit consists of two major parts: upper assembly and lower assembly.

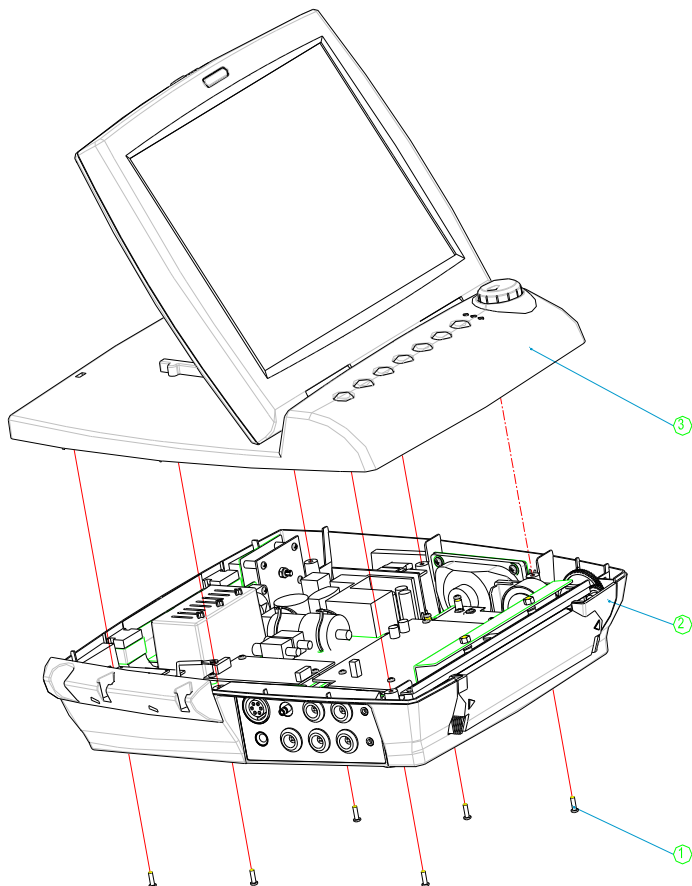

To disassemble the main unit,

- 1) Fold the LCD display completely flat.
- 2) Carefully place the monitor upside down on a flat surface covered with cloth or other protecting pad.
- 3) With a cross-head screw driver, remove the six screws securing the upper assembly to the lower assembly.
- 4) Hold both upper assembly and lower assembly together, place the monitor upright again.
- 5) Carefully lift up the upper assembly and place it upside down on the left side of the lower assembly.

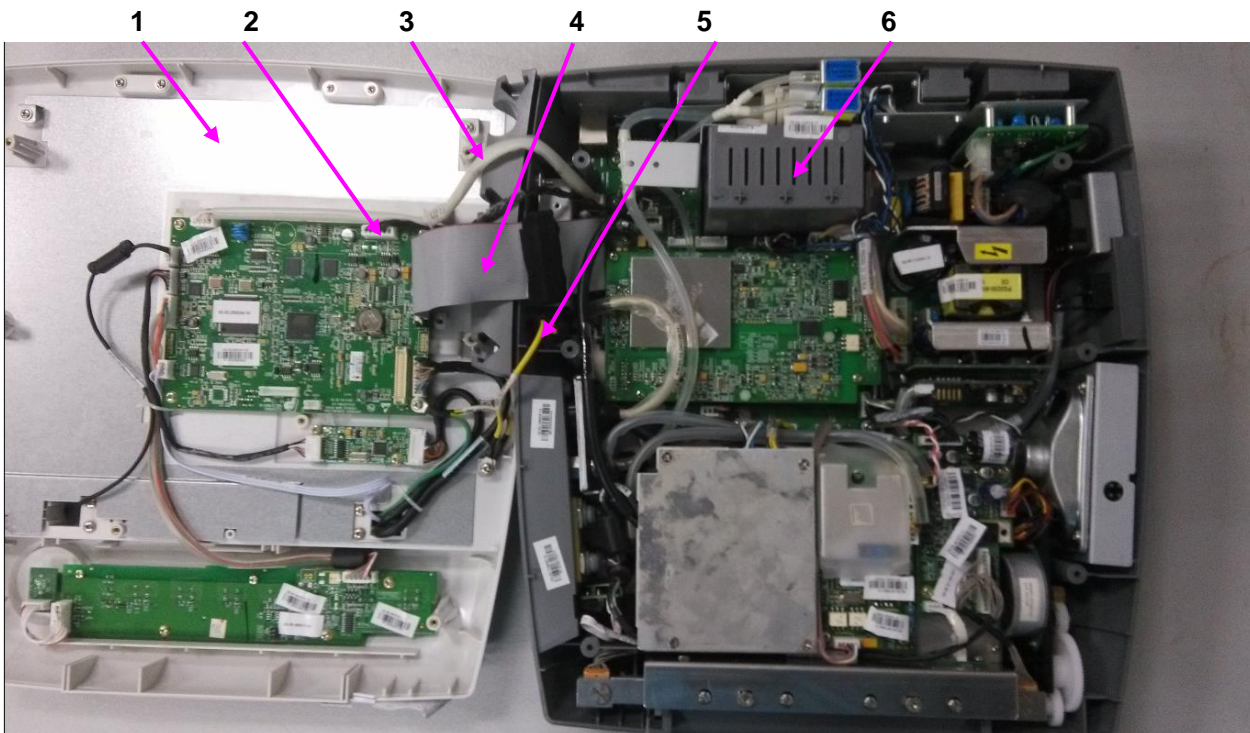

- 1 – Upper assembly
- 2 –Main control board Power Cable
- 3 –Main Control Board & Bottom Interfaces Board Ethernet Network Cable
- 4 –Main Control Board & Bottom Interfaces Board Connecting Cable
- 5 –Ground Wire (connecting the upper assembly)
- 6 – Lower assembly

6) Disconnect the cables/wires to separate the two parts.

10.4 Disassembling the Lower assembly

10.4.1 Replacing the FM Module

To remove the FM module,

- 1) Separate the upper assembly and the lower assembly.
- 2) Remove the four screws on the FM module shield cover.
- 3) Disconnect all the wires.
- 4) Remove the studs/screw securing the FM module.

To replace the FM module,

Replace the FM module in a reverse procedure. Refer to the following illustration when connecting wires. Ensure they are all correctly connected.

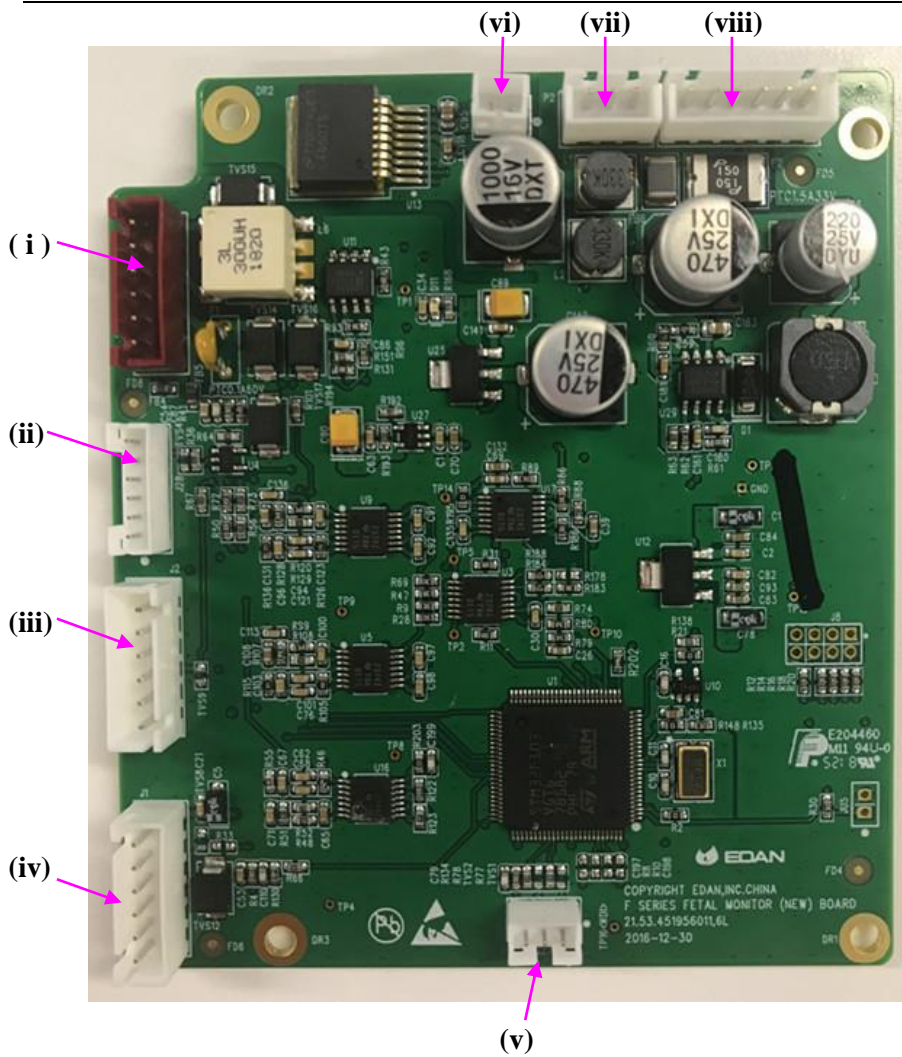

No. Connect to

- i Toco Socket
- ii US2 Socket
- iii Bottom Interfaces Board (J18)
- iv US1 Socket
- v Mark Socket
- vi Speaker
- vii Bottom Interfaces Board (J4)
- viii Power Module

10.4.2 Replacing the Print Controlling Board

To remove the print controlling board,

- 1) Separate the upper assembly and the lower assembly.
- 2) Disconnect all the wires on the PCBA.
- 3) Remove the three screws securing the PCBA.

To replace the print controlling board,

Replace the print controlling board in a reverse procedure. Refer to the following illustration when connecting wires. Ensure they are all correctly connected.

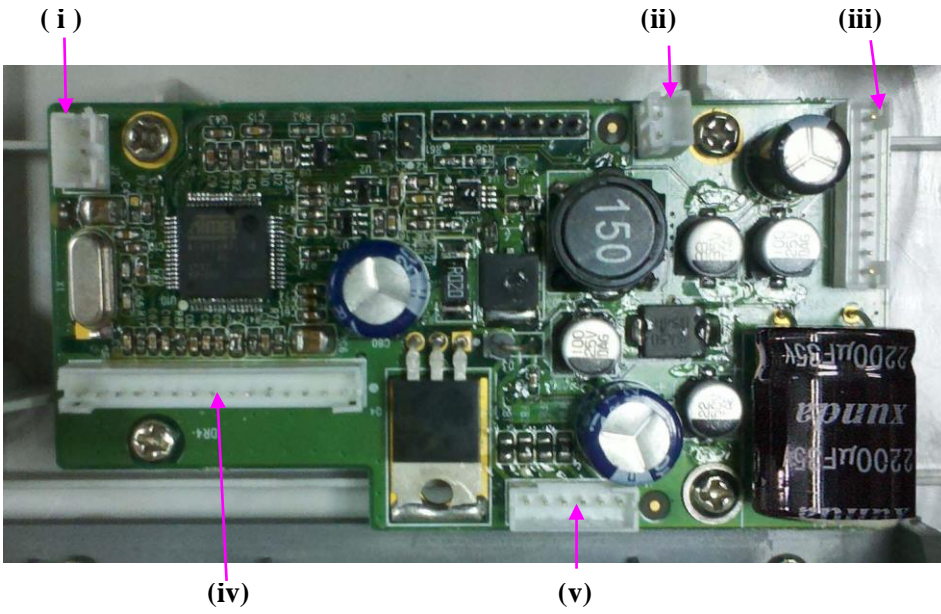

No. Connect to

- i Paper Sensor
- ii Paper Drawer Detector
- iii Bottom Interfaces Board
- iv Print head
- v Gear Assembly

10.4.3 Replacing the Gear Assembly

To remove the gear assembly,

- 1) Separate the upper assembly and the lower assembly.
- 2) Disconnect the wires' connector from the print controlling board.
- 3) Remove the three screws securing the gear assembly.

To replace the gear assembly,

Replace the gear assembly in a reverse procedure. Ensure the wires' connector is correctly connected to the print controlling board.

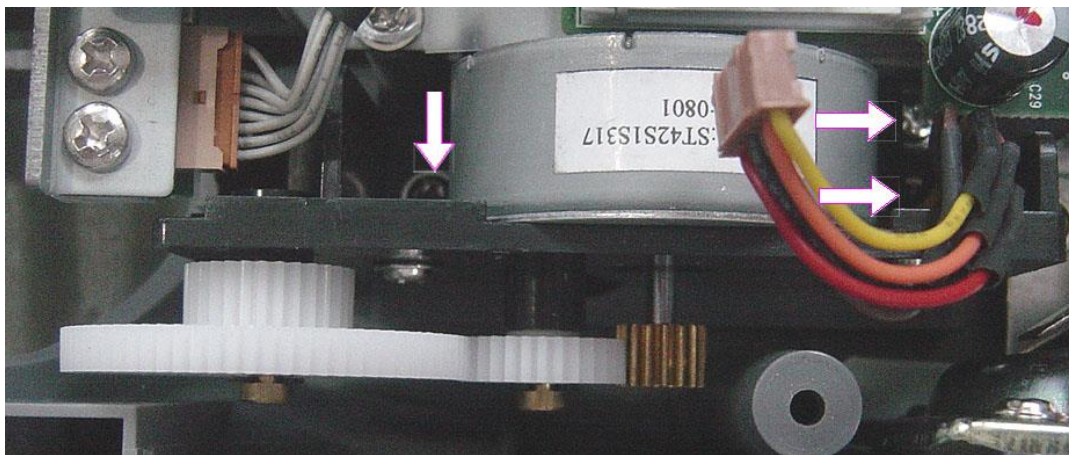

10.4.4 Replacing the Speaker

To remove the speaker,

- 1) Separate the upper assembly and the lower assembly.
- 2) Unplug the speaker wires' connector from the FM module.
- 3) Remove the three screws securing the speaker frame.
- 4) Remove the four screws securing the speaker to the frame.

To replace the speaker,

Replace the speaker in a reverse procedure. Ensure the wires' connector is correctly connected to the FM module.

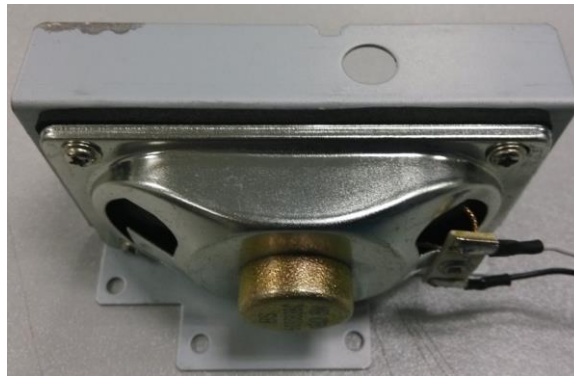

10.4.5 Replacing the Power Module

To remove the power module,

- 1) Separate the upper assembly and the lower assembly.
- 2) Disconnect all the wires on the module.
- 3) Remove the four screws securing the module.

To replace the power module,

Replace the power module in a reverse procedure. Refer to the following illustration when connecting wires. Ensure they are all correctly connected.

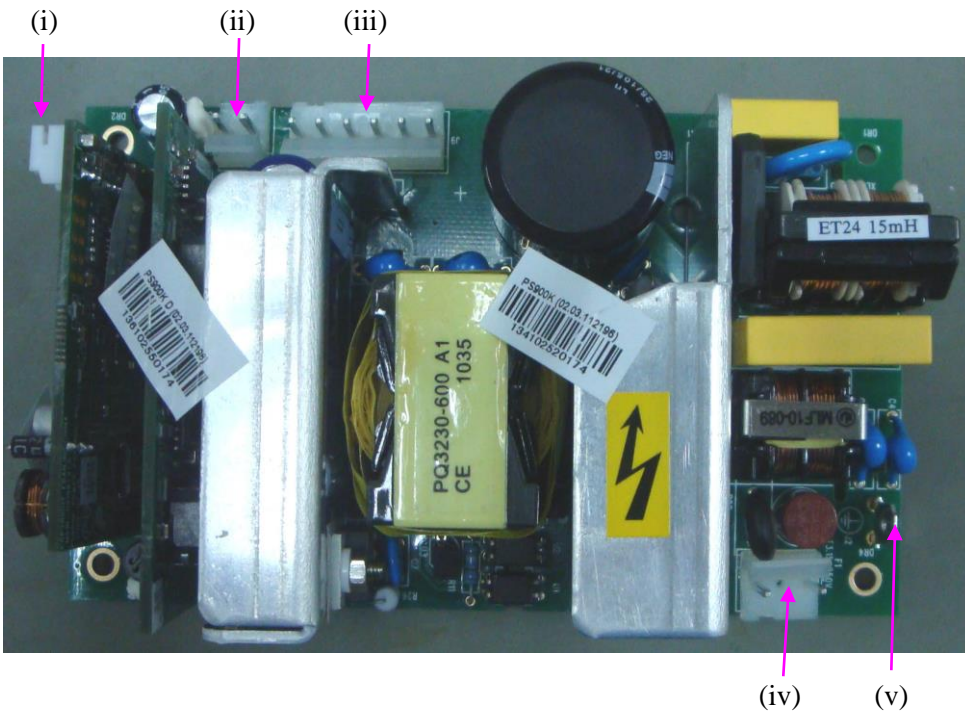

- No. Connect to**
- i Power Switch
 - ii Battery Interface Board
 - iii FM module , Print Control Board and Bottom Interface Board
 - iv Power Interface Board
 - v Green/Yellow Ground Wire (connects to power interface board)

10.4.6 Replacing the Fan

To remove the fan,

- 1) Separate the upper assembly and the lower assembly.
- 2) Remove the two screws securing the fan frame.
- 3) Remove the four screws securing the fan to the frame.



To replace the fan,

Replace the fan in a reverse procedure. Ensure the wires' connector is correctly connected to connector on the power cable bundle.

10.4.7 Replacing the Power Interface Board

To remove the power interface board,

- 1) Separate the upper assembly and the lower assembly.
- 2) Unplug the power wires connector from the power interface board. Using pliers to release the ground wire.
- 3) Remove the three screws securing the power interface board.

To replace the power interface board,

Replace the power interface board in a reverse procedure. Ensure the wires are correctly connected.

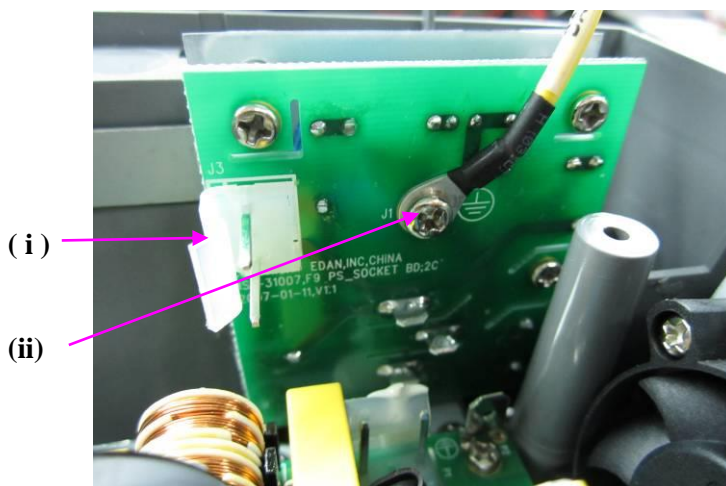

No. Connect to

- i Power Module
- ii Grounding Wires of the Power Module

10.4.8 Replacing the NIBP Module

To remove the NIBP module,

- 1) Separate the upper assembly and the lower assembly.
- 2) Disconnect the wire connecting the module to the bottom interface board. Detach the plastic tube from the NIBP socket.
- 3) Remove the four screws securing the NIBP module.

To replace the NIBP module,

Replace the module in a reverse procedure. Ensure the wires are correctly connected.



10.4.9 Replacing the SpO₂ Module

To remove the SpO₂ module,

- 1) Separate the upper assembly and the lower assembly.
- 2) Detach the F9 X12-EDAN NIBP board from the SpO₂ module.
- 3) Remove the four screws securing the F9 X12-EDAN NIBP board.
- 4) Remove the two studs/screws securing the module.

To replace the SpO₂ module,

Replace the SpO₂ module in a reverse procedure. Refer to the following illustration when connecting board-to-board connectors. Ensure they are all correctly connected.

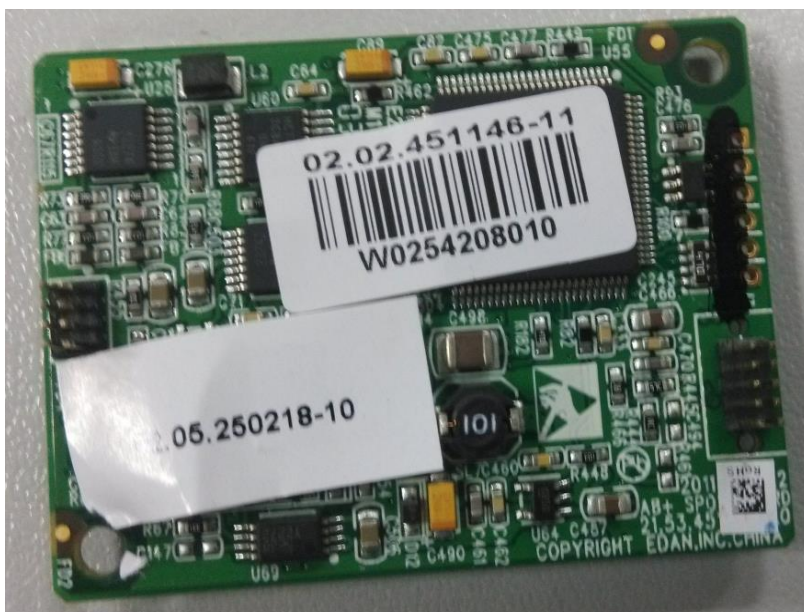

10.4.10 Replacing the F9 X12-EDAN NIBP Board

To remove the F9 X12-EDAN NIBP board,

- 1) Separate the upper assembly and the lower assembly.
- 2) Detach the F9 X12-EDAN NIBP board from the SpO₂ module.
- 3) Remove the four screws securing the F9 X12-EDAN NIBP board.

To replace the F9 X12-EDAN NIBP board,

Replace the F9 X12-EDAN NIBP board in a reverse procedure. Refer to the following illustration when connecting wires. Ensure they are all correctly connected.

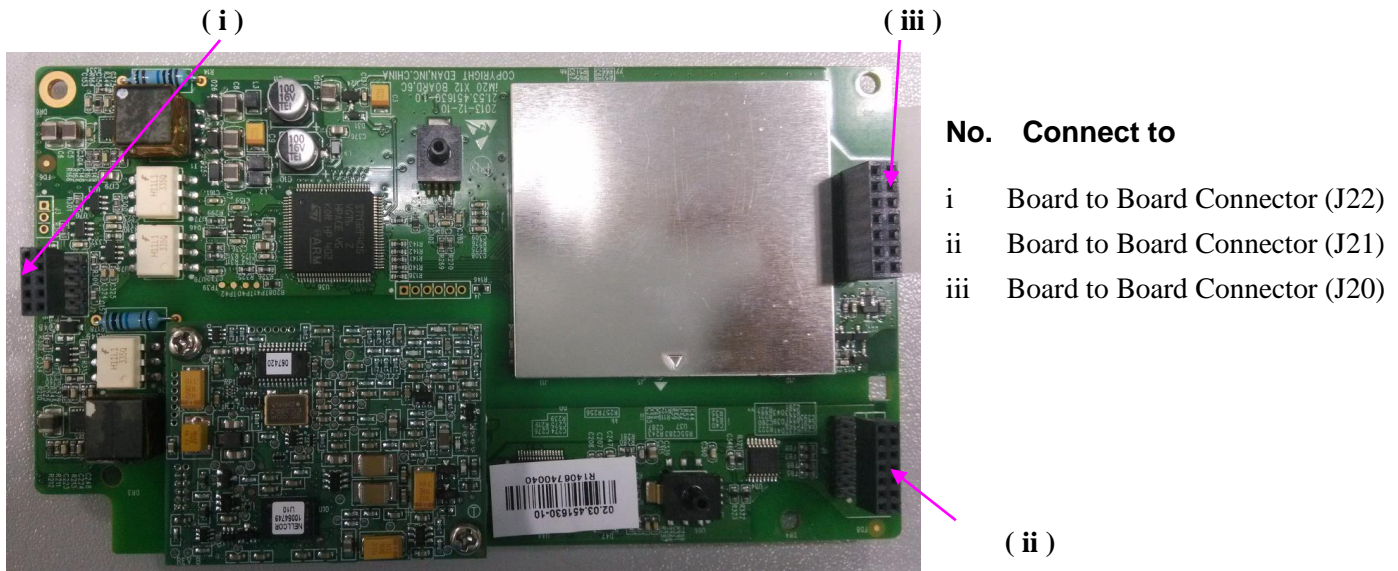

10.4.11 Replacing the Main Parameter Module Interface Board

To remove the main parameter module interface board,

- 1) Separate the upper assembly and the lower assembly.
- 2) Disconnect all the wires on the board.
- 3) Remove the seven screws securing the board.
- 4) Remove the four small plastic columns securing the board.

To replace the bottom interface board,

Replace the bottom interface board in a reverse procedure. Refer to the following illustration when connecting wires. Ensure they are all correctly connected.

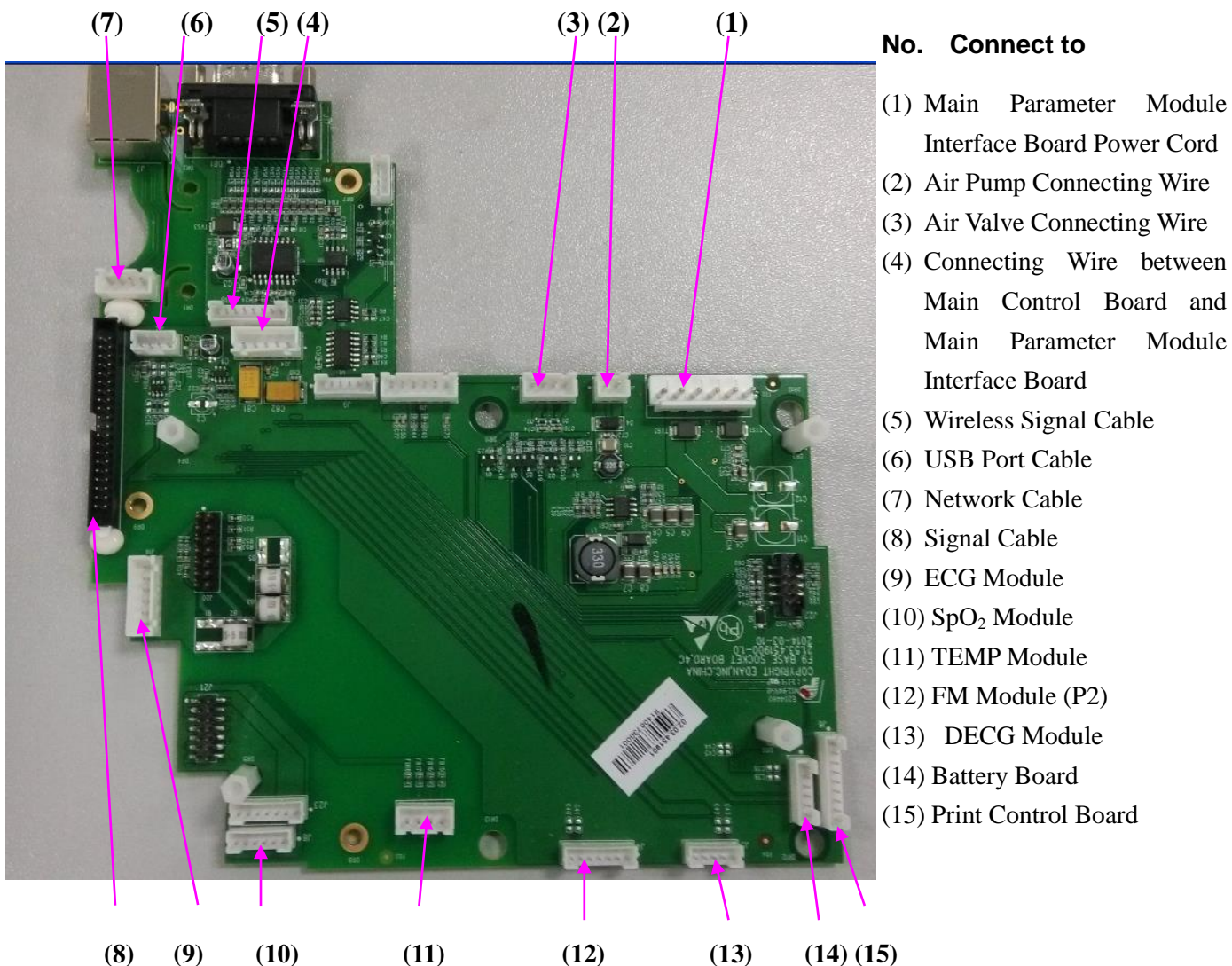

10.4.12 Replacing the Printhead

To remove the printhead,

- 1) Separate the upper assembly and the lower assembly.
- 2) Loosen the FM module by removing its fixing screws.
- 3) Unplug the connectors of the printhead signal cable and paper sensor cable from the print control board, and then loosen the print control board by removing its fixing screws.

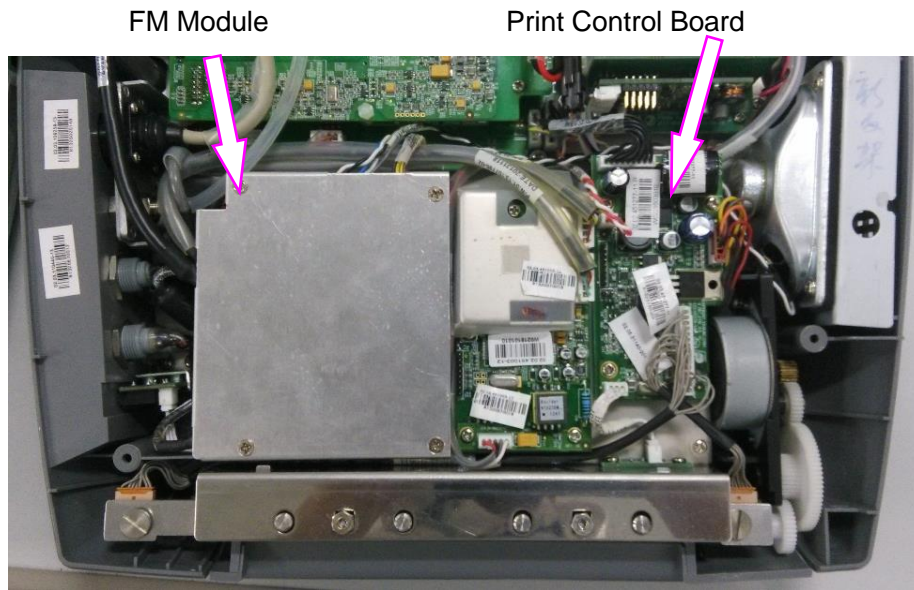

- 4) Remove the film that separates the boards and the metal piece (paper drawer cover).
- 5) Remove the screws ③-⑥, loose the screws ①-② and then rotate the metal retainers sideward to release the printhead connecting board.

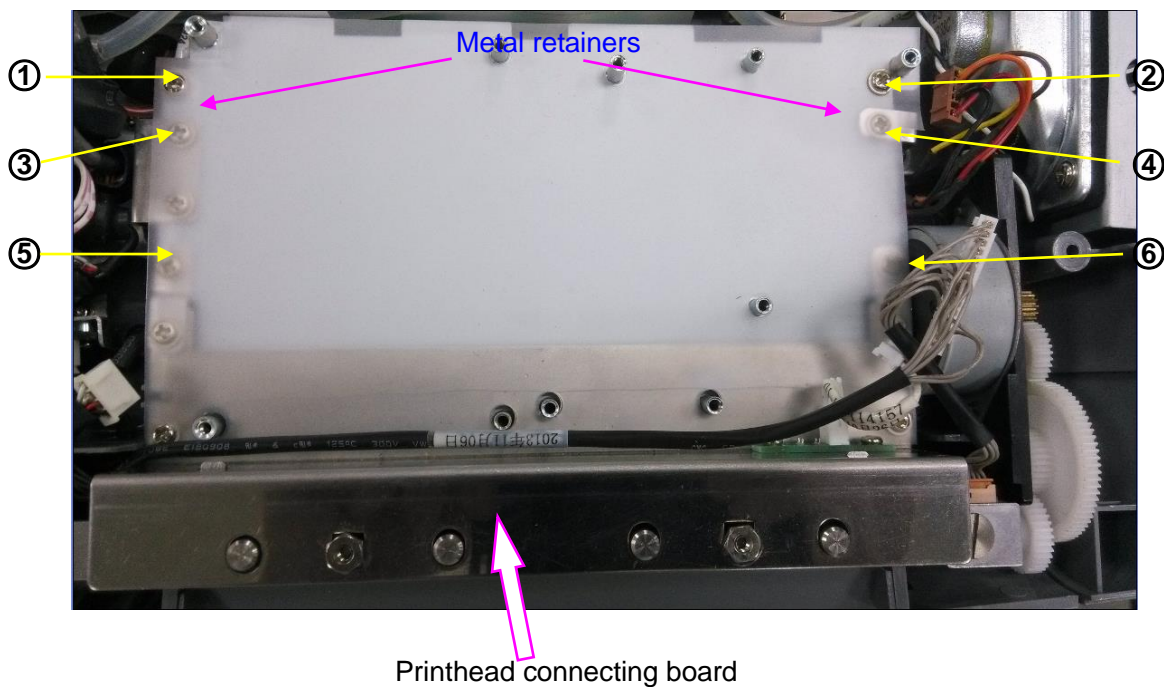

- 6) Take the printhead connecting board out from the monitor and then remove the four screws that fix the printhead.

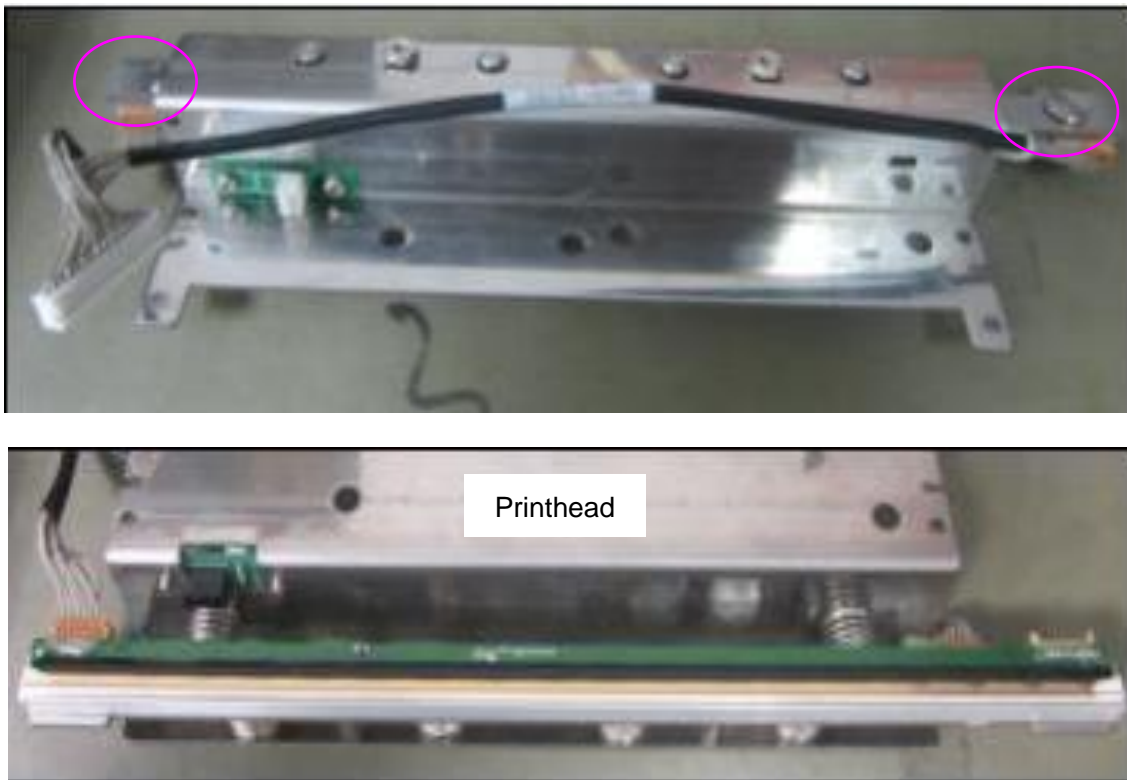

To replace the printhead,

Replace the printhead in a reverse procedure. The connector of the paper sensor cable is supposed to be connected to J2 socket of the print control board. The connector of the printhead signal cable is supposed to be connected to J5 socket of the print control board.

CAUTION

The thermal printhead is a fragile part. Handle it with care.

10.5 Disassembling the Upper Assembly

10.5.1 Replacing the Main Control Board

To remove the main control board,

- 1) Separate the upper assembly and the lower assembly.
- 2) Disconnect all the wires on the main control board.
- 3) Remove the four screws securing the board.

To replace the main control board,

Replace the main control board in a reversal procedure. Refer to the following illustration when connecting wires. Ensure they are all correctly connected.

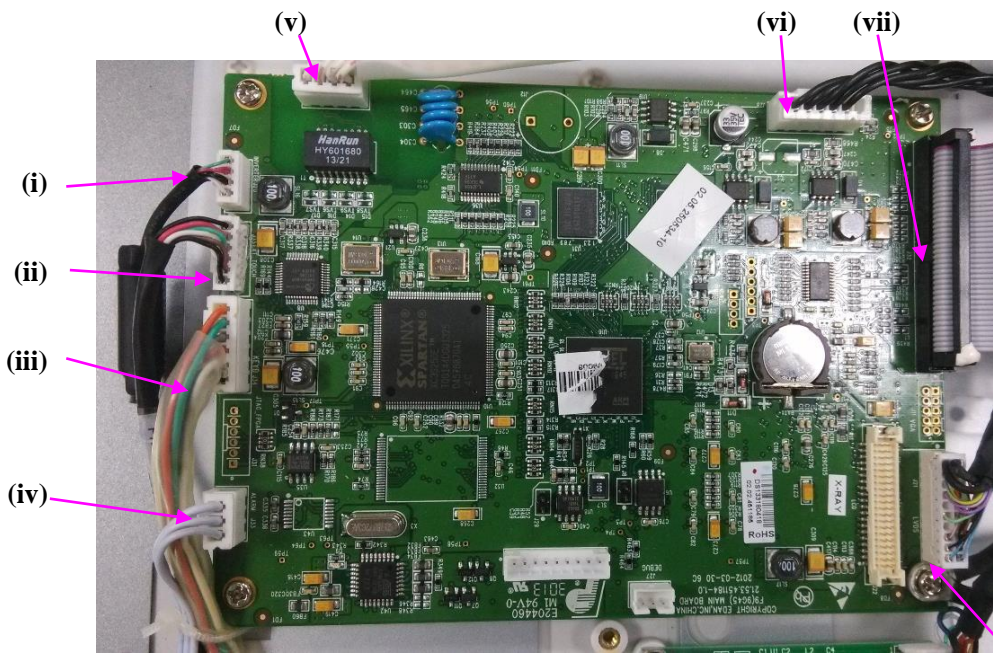

- | No. | Connect to... |
|------|--|
| i | LCD Backlight Board |
| ii | Touchpad |
| iii | Key Board |
| iv | Alarm Indicator |
| v | Network Socket of Bottom Interface Board |
| vi | Power Module |
| vii | Bottom Interface Board |
| viii | LCD Assembly |

10.5.2 Replacing the Key Board

To remove the key board,

- 1) Separate the upper assembly and the lower assembly.
- 2) Disconnect all the wires on the key board.
- 3) Remove the four screws securing the board.

To replace the key board,

Replace the board in a reverse procedure. Refer to the following illustration when connecting wires. Ensure they are all correctly connected.



- | No. | Connect to |
|-----|--|
| i | Main Control Board |
| ii | Ground Wire (connects to the upper assembly) |
| iii | Control Knob |

10.5.3 Replacing the LCD

To open the LCD assembly,

- 1) Separate the upper assembly and the lower assembly.
- 2) Disconnect the LCD backlight board cable, alarm indicator board cable and LCD driving board cable from the main control board (shown with arrows).

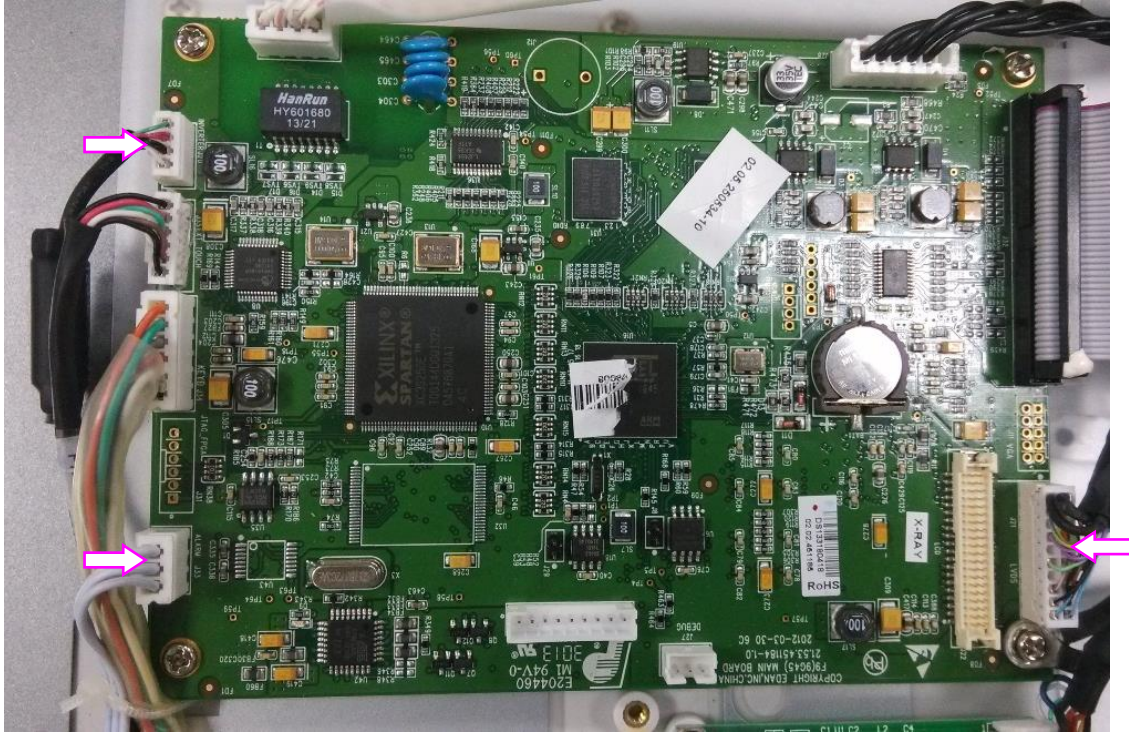

- 3) Remove the four screws on the top assembly.

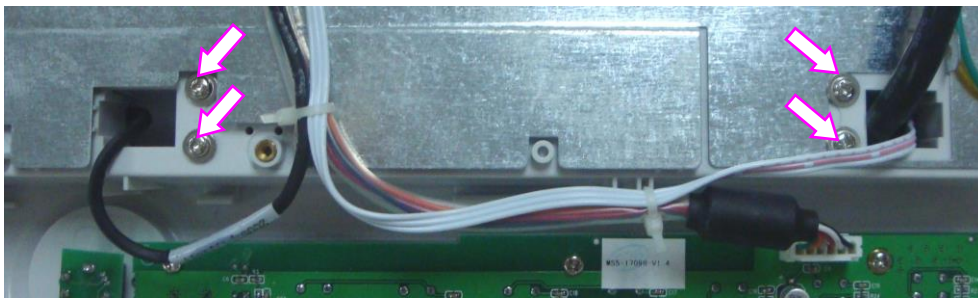

- 4) Place the top assembly upright. Open the display assembly completely. Remove four screws securing the display assembly stander.

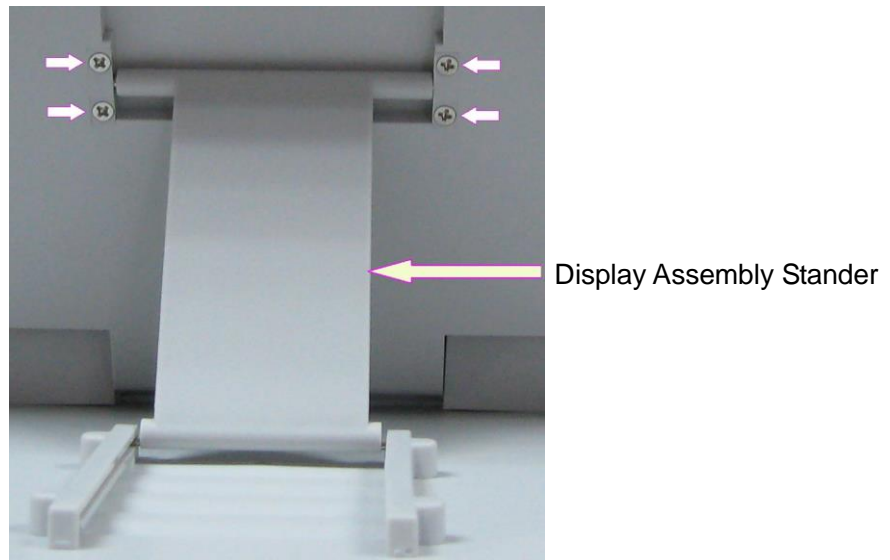

- 5) Remove seven screws on the back of display assembly.

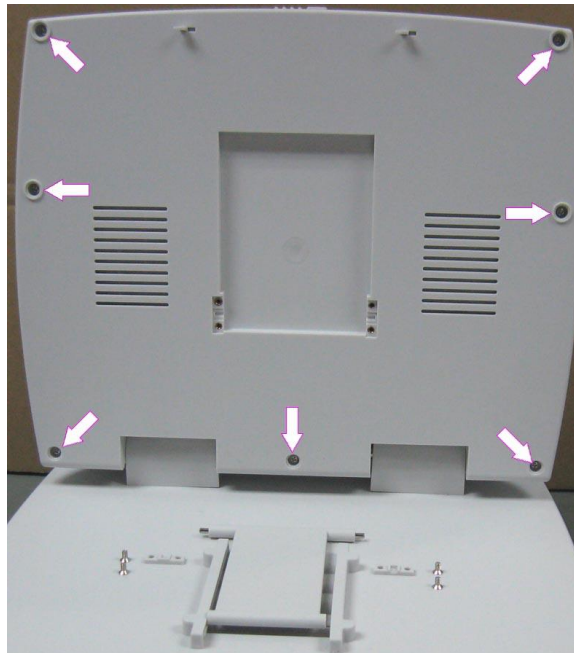

- 6) Open the display assembly with care. You will find the alarm indicator board, LCD, LCD driving board and LCD backlight board.

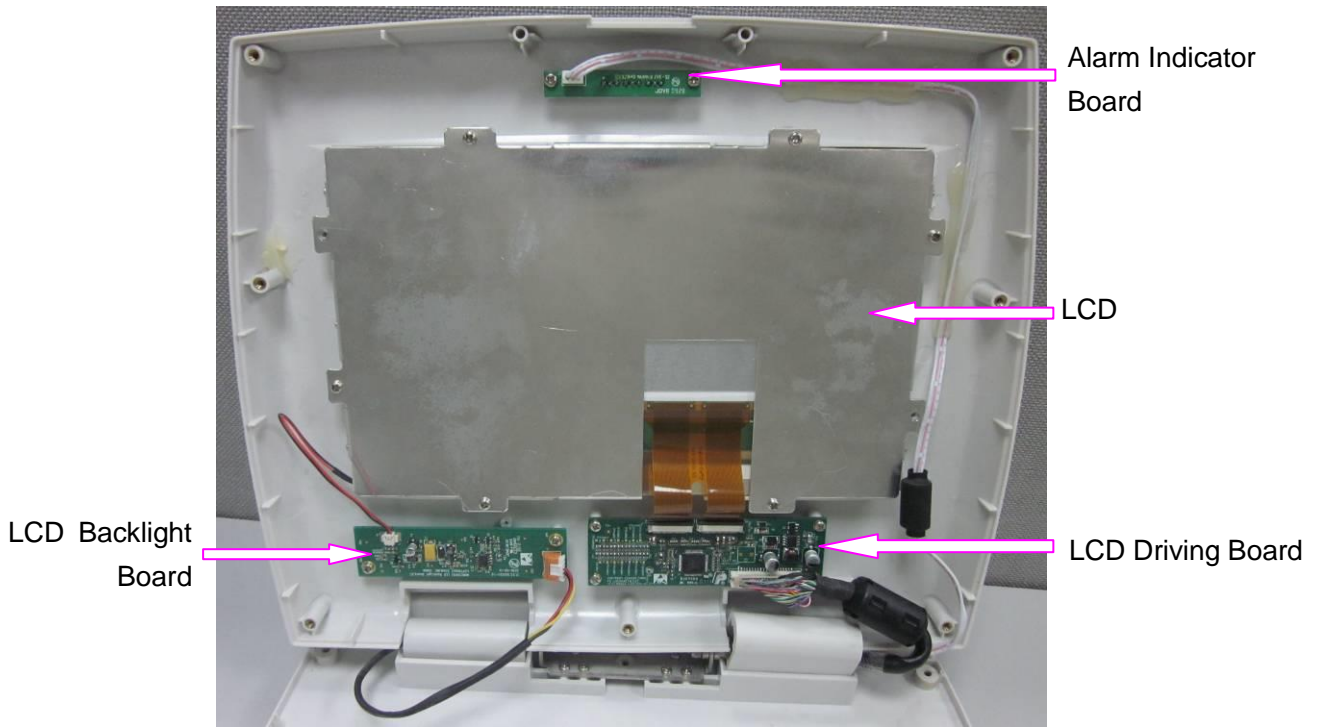

- 7) Remove the two roll shaft covers and pull out the three wires (LCD backlight board power wire, LCD data wire and alarm indicator wire).



- 8) Remove the two screws on the alarm indicator board.
- 9) Disconnect the LCD backlight wire and remove the two screws on the LCD backlight board.
- 10) Move the cable lock in the direction of the arrows to release it; disconnect the LCD cables; remove the four screws on the LCD driving board.

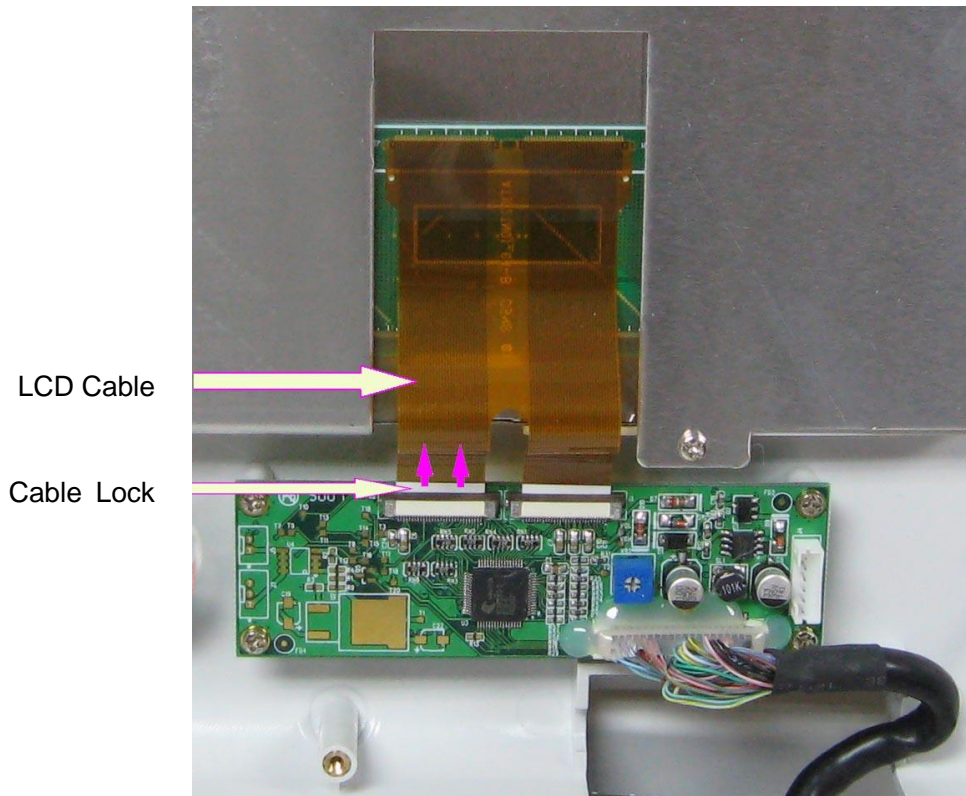

11) Remove the eight screws on the LCD.

10.5.4 Replacing the Power Inverter Board

To remove the power inverter board,

- 1) Separate the upper assembly and the lower assembly.
- 2) Open the LCD assembly using the first 6 procedures introduced in 10.5.3.
- 3) Disconnect all the wires on the power inverter board.
- 4) Remove the two screws securing the board.

To replace the power inverter board,

Replace the board in a reverse procedure. Refer to the following illustration when connecting wires. Ensure they are all correctly connected.

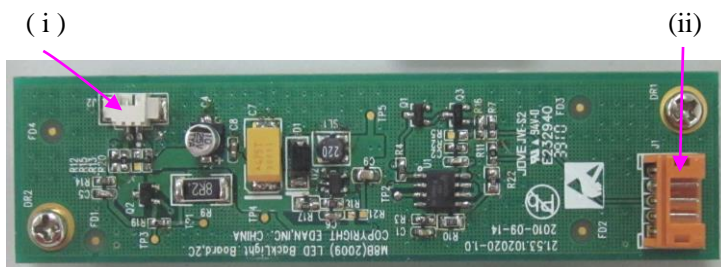

No. Connect to

- i LCD Backlight Wire
- ii Main Control Board

Chapter 11 Periodic Tests

11.1 Safety Tests

Safety tests should be performed by qualified personnel every 6 to 12 months, and each time after service.

Use a standard safety tester to perform safety tests. The tester must comply with IEC/EN 60601-1 or the local standards and statutes.

Refer to the accompanying operation instructions of the tester for test procedure details.

11.2 Performance Tests

The performance test should be done once every 12 months or when you suspect the measurement is incorrect.

11.2.1 FHR Performance Test

This test checks the performance of FHR measurement.

- 1) Switch on the monitor.
- 2) Connect the ultrasound transducer to the monitor.
- 3) Select the fetal heart sound for this channel.
- 4) Increase the loudspeaker volume to an audible level.
- 5) Open the palm of one hand and hold still while the other hand holding a US transducer moves back and forth facing the open palm, as illustrated in the picture below. The fetal heart sound should be heard during the whole process.

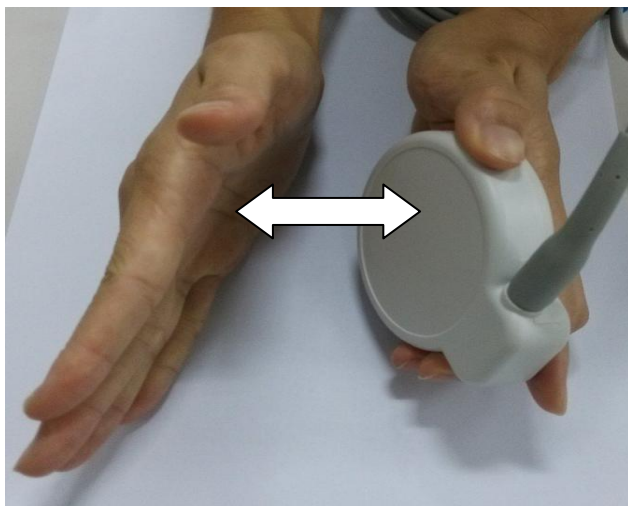

11.2.2 TOCO Performance Test

This test checks the performance of TOCO measurement.

- 1) Connect the TOCO transducer to the fetal monitor, adjust the pressure test tool to balance and lay the transducer horizontally on the tool surface so that the pressure spot of the tool is right in the middle of the transducer. Press **AUTO ZERO** to return to zero and the value on the monitor display is 10.
- 2) Add a weight of 50 grams and check if the value on the display is 34 ± 8 . Press **AUTO ZERO** to return to zero.
- 3) Add another weight of 50 grams and check if the value on the display is 34 ± 8 .

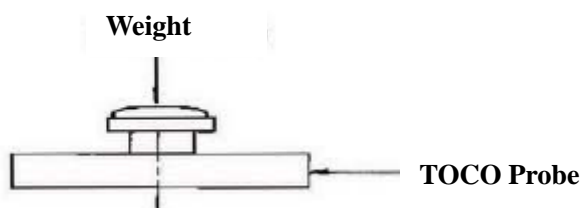

If a TOCO transducer fails the test, repeat this test with another transducer. If the second one passes the test, defect of the first transducer is confirmed. Replace it with a good one. If the second transducer fails the test as well, check the monitor.

11.2.3 ECG Performance Test

This test checks the performance of ECG measurement.

Required Equipment: ECG Simulator

- 1) Connect the equipment and the monitor as shown below:

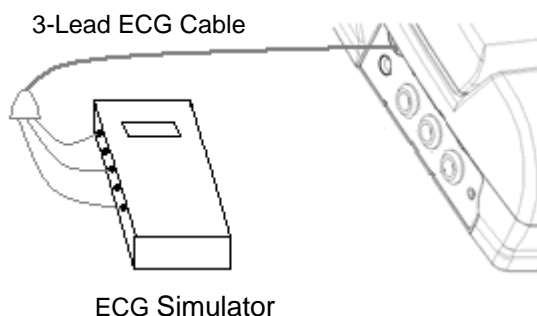

- 2) Switch on the monitor.
- 3) Generate the heart rate 30 bpm, 120 bpm and 240 bpm in turn.
- 4) Check if the HR value displayed on the screen is accurate. Error within 2 bpm is acceptable.

11.2.4 SpO₂ Performance Test

This test checks the performance of SpO₂ measurement.

Required Equipment: SpO₂ Simulator

- 1) Connect the equipment and the monitor as shown below:

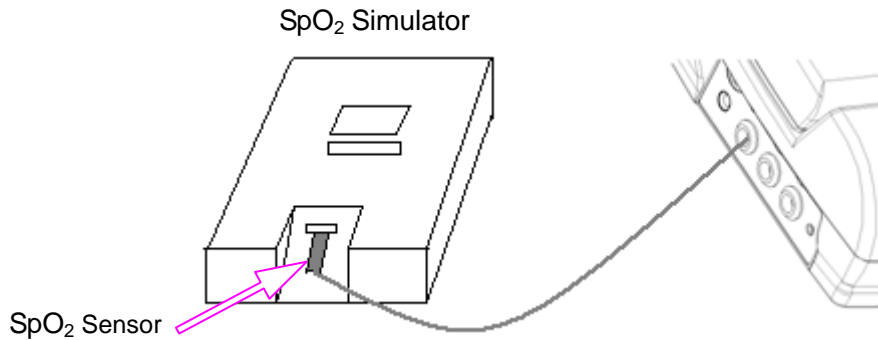

- 2) Switch on the monitor.
- 3) Generate the SpO₂ signal 98% and 100% in turn.
- 4) Check if the SpO₂ value displayed on the screen is accurate. Error within 2% is acceptable.

11.2.5 NIBP Performance Test

This test checks the performance of NIBP measurement.

Required Equipment: Blood Pressure Simulator

- 1) Connect the equipment and the monitor as shown below:

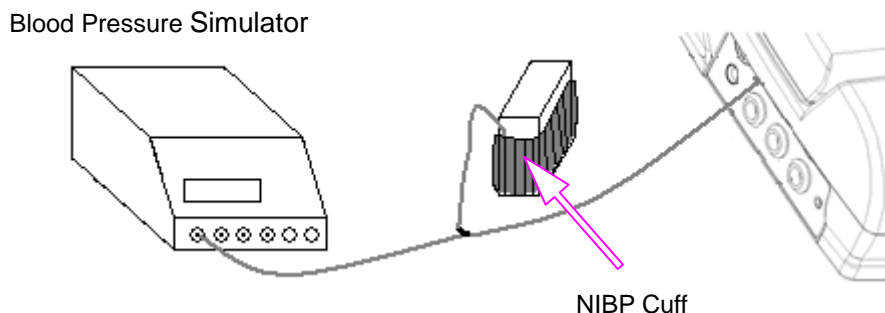

- 2) Switch on the monitor.
- 3) Generate the NIBP signal 270/215 (235) and 40/10(20) in turn.
- 4) Check if the NIBP value displayed on the screen is accurate. Error within 8 mmHg is acceptable.

11.2.6 TEMP Performance Test

This test checks the performance of TEMP measurement.

Required Equipment: Resistance Box

- 1) Connect the equipment and the monitor as shown below:

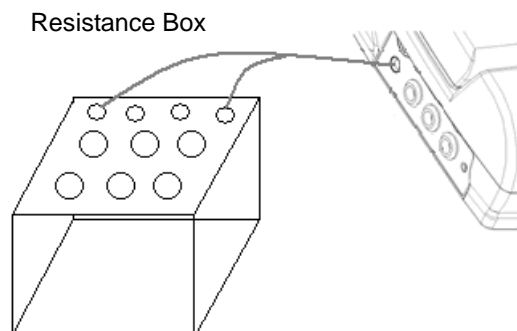

- 2) Switch on the monitor.
- 3) Adjust the resistance value to 32657Ω , 6017Ω and 3602.4Ω in turn.
- 4) The TEMP numeric value displayed on the screen correspond to $0\text{ }^{\circ}\text{C}$, $37\text{ }^{\circ}\text{C}$ and $50\text{ }^{\circ}\text{C}$.
Error within $0.2\text{ }^{\circ}\text{C}$ is acceptable.

Appendix 1 Renewal Parts

CAUTION

Only connect the renewal parts supplied by EDAN to the monitor.

Repair Part	Part Number	Repair Part	Part Number
FM Module	02.03.451221 (cordless system)/ 02.03.110440	Main control board	02.03.220099
DECG Module	02.03.451003	Key Board	02.03.451013
Print Controlling Board	02.03.451277	LCD	01.16.045058
Power Module	02.01.112205	Alarm Indicator Board	02.02.114346
Main Parameter Module Interfaces Board	02.03.220156	Serial Port Cable	01.13.107702
Speaker	02.01.210047	Serial Port to RJ45 Cable #1	01.13.107974
Fan	21.58.047299	Serial Port to RJ45 Cable #2	01.13.036124
Power Interface Board	02.02.114139	Y-Shape Signal Cable	01.13.036301
Printhead	01.17.02385		

Appendix 2 Connecting to OB TraceVue System

Preparation

Prior to connecting F6/F6 Express to the OB TraceVue obstetrical documentation and surveillance system of Philips, make sure that:

- 1) **Net Version** of F6/F6 Express on the **Network Setup** interface has this option: **PHILIPS**.
- 2) The OB TraceVue system of Philips has a network interface (DB9 or RJ45) available.
- 3) You have the proper connecting cable.

If a DB9 interface is available, you need a Serial Port Cable (01.13.107702):



Figure A2-1 Serial Port Cable

If an RJ45 interface is available, you need a Serial Port to RJ45 Cable (01.13.107974 or 01.13.036124). The part numbers are shown on the labels attached to the cables.



Figure A2-2 Serial Port to RJ45 Cable

Check other bedside monitors in the OB TraceVue system to see if protocol converters (as shown in the following illustrations) are used.



Figure A2-3 Protocol Converter



Figure A2-4 A Protocol Converter Used on a Monitor

If protocol converters are used on other bedside monitors, connect F6/F6 Express with the Serial Port to RJ45 Cable #2 (01.13.036124). Otherwise use the cable #1 (01.13.107702).

Connection

- 1) Connect the T840 telemetry system to F6/F6 Express using the Y-shape signal cable.
- 2) Put the convex plug of the Serial Port to RJ45 Cable into the DB9 socket of the signal cable; put the concave plug of the Serial Port Cable into the free DB9 interface of the OB TraceVue system.

OR

Put the convex plug of the Serial Port to RJ45 Cable into the DB9 socket of the signal cable; put the RJ45 plug of the Serial Port to RJ45 Cable into the free RJ45 interface of the OB TraceVue system.

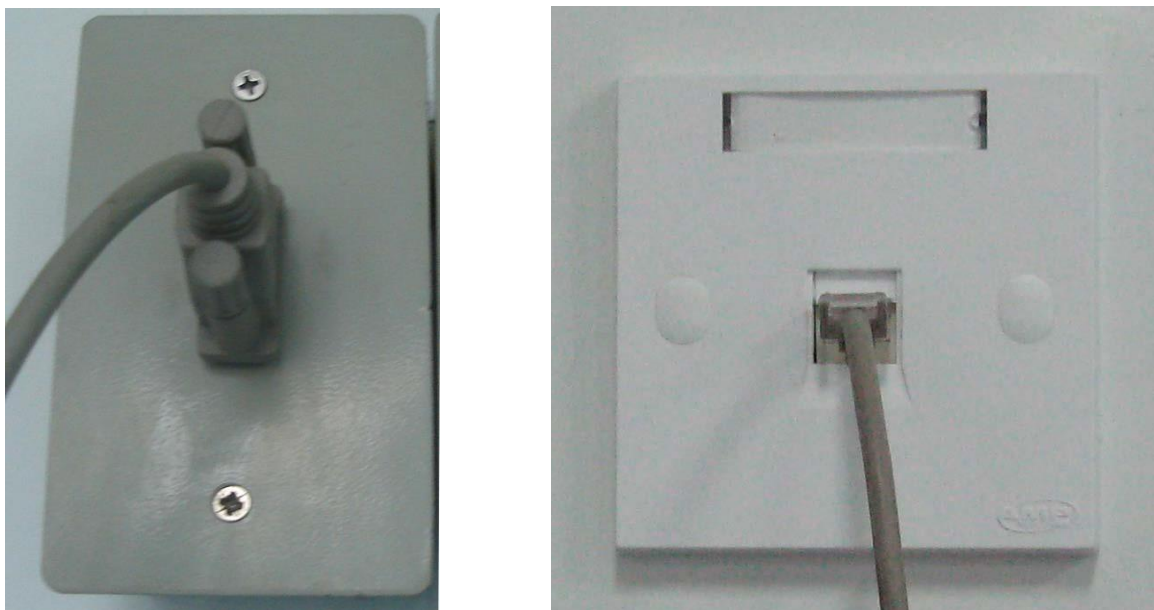

Figure A2-5 Connecting DB9 and RJ45 interfaces of the OB TraceVue system

Setting

Set the Net Version of F6/F6 Express to **PHILIPS**. (Refer to 5.8 *Changing Net Version*)

Restart F6/F6 Express.

Validation

- 1) Switch F6/F6 Express to Demo mode.
- 2) Observe the surveillance window of the OB TraceVue system. If data from F6/F6 Express is transferred to the system, the connection succeeds. Otherwise check the connection or try on another interface of the system.

NOTE:

The identity number of this interface is preset. The device No. of F6/F6 Express does not take effect in this system.

P/N: 01.54.456559

MPN: 01.54.456559014



EDAN INSTRUMENTS, INC.

#15 Jinhui Road, Jinsha Community, Kengzi Sub-District
Pingshan District, 518122 Shenzhen, P.R.China

Email: info@edan.com.cn

TEL: +86-755-2689 8326 FAX: +86-755-2689 8330

Website: www.edan.com.cn



EC REPRESENTATIVE

Shanghai International Holding Corp. GmbH
Eiffestrasse 80, 20537 Hamburg Germany

TEL: +49-40-2513175

E-mail: shholding@hotmail.com