

Operating Instructions

Atria 3100 Electrocardiograph
Atria 6100 Electrocardiograph

Part Number 70-00082-01 A



CARDIAC SCIENCE

This manual contains instructions for both the Atria 3100 and the Atria 6100.



Copyright © 2007 Cardiac Science Corporation
All rights reserved.

Cardiac Science Corporation
3303 Monte Villa Parkway
Bothell, WA 98021, USA

Toll Free: +1.800.426.0337
Telephone: +1.425.402.2000
Email: techsupport@cardiacscience.com
Website: www.cardiacscience.com



MDSS GmbH
Schiffgraben 41
D-30175 Hannover
Germany
Tel: +49 511 62 62 86 30
Fax: +49 511 62 62 86 33

Table of Contents

| | | |
|------------------|---|------------|
| | Intended Use | v |
| | Warnings | v |
| | Definitions of Symbols Used | vi |
| | Quick Steps | |
| | Atria Electrocardiograph | ix |
| Chapter 1 | General Information | 1-1 |
| | Inspection at Delivery | 1-1 |
| | General Description | 1-1 |
| | Interpretive Analysis Program | 1-2 |
| | Using Multiple Electrical Apparatus | 1-3 |
| | Password Protection | 1-3 |
| | Help Menu | 1-4 |
| | Automatic Information Entry | 1-4 |
| | Paperless Workflow | 1-4 |
| Chapter 2 | Equipment Setup | 2-1 |
| | External Connections | 2-1 |
| | Patient Cable | 2-3 |
| | Powering the Atria On and Off | 2-3 |
| | Charging the Battery | 2-4 |
| | Loading Recording Paper | 2-5 |
| Chapter 3 | User Interface | 3-1 |
| | Keyboard | 3-3 |
| | Display Atria 6100 | 3-7 |
| | Display Atria 3100 | 3-10 |
| Chapter 4 | User Settings | 4-1 |
| | Overview | 4-1 |
| | Setup Menu | 4-2 |
| | Print Setup Report | 4-2 |
| | ECG Settings | 4-2 |
| | Waveform Preferences | 4-7 |
| | Rhythm | 4-9 |
| | Patient Settings | 4-11 |
| | Directory Settings | 4-12 |
| | System Settings | 4-13 |
| Chapter 5 | Communications Setup | 5-1 |
| | Equipment Connections | 5-2 |
| | Grounding | 5-3 |
| | Network Setup | 5-3 |
| | External Printer Setup | 5-8 |
| | Setup Fax | 5-10 |
| | Setup Email | 5-10 |
| | Setup EMR Communications | 5-12 |

| | | |
|-------------------|--|-------------|
| Chapter 6 | <i>Patient Preparation</i> | 6-1 |
| | Overview | 6-1 |
| | Patient Preparation | 6-2 |
| | Skin Preparation | 6-2 |
| | Sensor Application | 6-3 |
| | Resting ECG Lead Placement & Coding Chart | 6-4 |
| | Disposable Resting ECG Sensors | 6-5 |
| | Reusable ECG Sensors | 6-6 |
| | Connecting Cables and Lead Wires | 6-8 |
| | Alternative Lead Placements | 6-8 |
| Chapter 7 | <i>Acquiring ECG Reports</i> | 7-1 |
| | Acquiring a Stat ECG | 7-1 |
| | Recommended Workflow | 7-1 |
| | Acquiring an ECG Using Pediatric Lead Placements | 7-3 |
| | ECG Reports | 7-3 |
| | ECG Tips | 7-4 |
| | Change Recorder Speed, Gain, Frequency Response | 7-5 |
| | Acquiring a Rhythm Report | 7-6 |
| | Acquiring an ECG Using Alternative Lead Placements | 7-6 |
| | Patient Demographics | 7-7 |
| Chapter 8 | <i>Patient Records</i> | 8-1 |
| | Working with Patient Records | 8-1 |
| | How to Display a Patient Record | 8-2 |
| | Communications Options | 8-7 |
| Chapter 9 | <i>Sample Printouts</i> | 9-1 |
| | Print Directory Report | 9-2 |
| | Setup Report | 9-3 |
| | Standard 12-Lead, 4-Channel ECG, Brief Statements | 9-5 |
| | Standard 12-Lead, 6-Channel ECG, Brief Statements | 9-6 |
| | Standard 3-Channel Rhythm & Manual ECG | 9-7 |
| | Measurement Matrix | 9-8 |
| | Median Complex, Brief Statements | 9-9 |
| Chapter 10 | <i>Troubleshooting</i> | 10-1 |
| | Basic Troubleshooting | 10-1 |
| | Trace Problems | 10-2 |
| | Printing | 10-4 |
| | Recognizing and Reducing ECG Artifacts | 10-5 |
| Chapter 11 | <i>Maintenance and Service</i> | 11-1 |
| | Once per Shift | 11-1 |
| | Annually | 11-3 |
| | Component Replacement | 11-3 |
| | Notice to Responsible Service Personnel | 11-7 |
| | Performance Disclosures | 11-7 |
| | EMC Declaration Tables | 11-10 |
| | Technical Specifications | 11-14 |
| Chapter 12 | <i>Measurement Matrix</i> | 12-1 |

Intended Use

Under the supervision of a qualified physician trained in ECG interpretation the Atria electrocardiograph can be used to record the electrical activity of the heart for the purpose of correlating the resultant waveforms with the health of the heart muscle tissue structures.

This equipment produces a resting 12-lead electrocardiogram which can be used as a first step for assessment of patients with cardiac arrhythmias, intraventricular conduction block, pre-excitation syndrome and ischemic heart disease. Records stored and used during the life of the patient can assist physicians in the diagnosis and natural history of heart related illnesses (such as coronary artery disease).

This equipment is not designed to produce a definitive interpretation nor exhaustive evaluation of the patient's heart but rather provide an effective beginning for evaluation of patients with heart abnormalities.

Warnings



WARNING

Shock hazard. Do not touch the Atria or patient during defibrillation. Otherwise, serious injury or death could result.



WARNING

Burn Hazard. Severe burns may result from improper placement of defibrillator paddles. Never position defibrillator paddles close to or over ECG sensors. Remove all chest sensors (V-Leads/ C-Leads) from the patient before defibrillation.

Read and follow all defibrillator instructions before attempting defibrillation.



WARNING

Operator or Patient Injury. Before performing procedure with the Atria, read and follow all safety procedures.



Caution

U.S. Federal law restricts this device to sale by or on the order of a physician.

Definitions of Symbols Used



Warning. Indicates serious injury or death hazard.



Caution. Indicates potential equipment damage or minor injury hazard.



Danger! High voltage.



Hazardous voltage.



Defibrillation-Protected Type CF Equipment.



Equipotentiality (used to label the grounding lug).



Alternating Current (AC).



Direct Current (DC).



Automatic Operation.



Manual Operation.



On/Standby.



Stop Function.



Modem port.



Ethernet port.



USB port.



Serial port.



Analog port.



Indoor, dry location use only.



No serviceable parts inside.



Manufacture date



Manufactured for



Meets or exceeds Council Directive 93/42/EEC, MDD, Class IIa.



Certified for both the U.S. and Canadian markets, to the applicable U.S. and Canadian safety standards.



Component is certified for both the U.S. and Canadian markets, to the applicable U.S. and Canadian safety standards.



Device or component is certified for the Japanese and/or Asian markets.

Quick Steps

Atria

Electrocardiograph

Connect Patient

Refer to the lead placement chart.



Power On

Press .

Acquire a STAT ECG

Press  two times.

Add Patient Demographics (to Stat ECG)





1. Select **Edit Demographics** from *ECG Review* menu.
2. Press .
3. Enter patient information.
4. Press  to *ECG Review* menu.

Note: Certain demographics changes prompt to reanalyze and print.

Print a Copy of ECG (from *ECG Review* menu)

1. Select **Print Copy of this ECG**.
2. Press .

Acquire ECG with new Patient Info

1. Press .
2. Select **Enter New Patient**.
3. Press .
4. Enter patient information.
5. Press  then .

For a Continuous Rhythm Print Out

Press .

Press  to stop rhythm printing.

User 1 and User 2 Selection

Press  +  for User 1.

Press  +  for User 2.

Help Menu

Press  + .

Precordial Lead Positioning

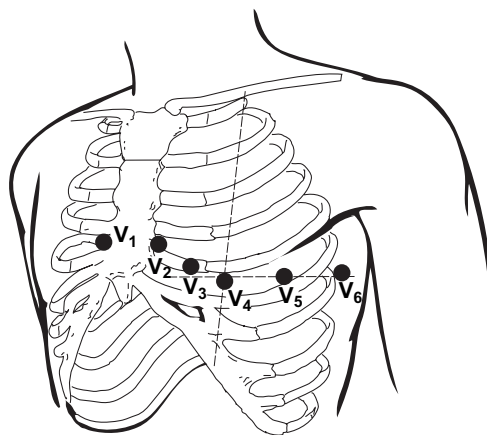

V₁ Fourth intercostal space at right margin of sternum

V₂ Fourth intercostal space at left margin of sternum

V₃ Midway between position V₂ and position V₄

V₄ Fifth intercostal space at junction of left midclavicular line

V₅ At horizontal level of position V₄ at left anterior axillary line

V₆ At horizontal level of position V₄ at left midaxillary line

Limb Lead Placement

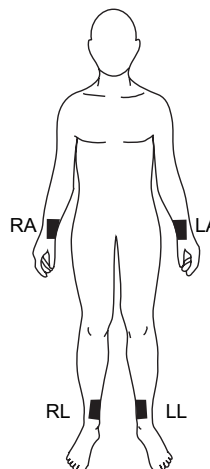

RA Above inside right wrist

LA Above inside left wrist



RL Above inside right ankle

LL Above inside left ankle

Power On

Press  to power ON.

Start a New Patient

1. Press  to return to the main display.
2. Press  to start a new patient.
3. Press .





Manage Patient Records



Press  for options.

Press  to scroll through options:

- **View Patient Directory**
- **Enter New Patient:** Enter patient information for future ECG recording
- **Print All New ECGs:** Print all unprinted ECGs
- **Print Directory:** Print list of saved records
- **Show Directory Status:** Number of unprinted or demographic-only records (Some items may not be listed, depending on previous actions)
- **Delete All Records**

Select Leads

Press  or  or  or  to select the lead triplet indicated on the key (for rhythm display and printouts).

Press  or  to select user-defined leads (Custom Lead 1 and Custom Lead 2, respectively). The selected leads will be printed on manual rhythm and auto rhythm reports.

Change Settings

Press  to change current speed setting.

Press  to change current gain setting.

Press  to change current artifact filter setting.

Press  to add a calibration pulse to the printout (manual or auto rhythm printouts only)

General Printing

(Depends on ECG sequence setting.)

Press  to acquire and print an ECG.

Press  to print an auto rhythm report.

Press  to print a manual rhythm report.

Press  to end the printout.

Press  to advance one sheet of paper.

Press  to stop any of the above functions.

Navigation



Press  to return to the main display.

Press  to scroll to the previous item in a list.

Press  to scroll to the next item in a list.

Press  to accept the current selection (or to select an item for editing).

Press  to return to the previous menu or display.

Press  or  to move the cursor within an edit field.
(Atria 6100 only)

Send Records

Press  for send record options.

Select desired options:

- **Send All New or Selected ECGs**
- **Select Records to Send**



NOTE: Communications option must be installed and configured to use this feature.

Configure System Settings

Press  to configure system settings.

Use the navigation buttons to select the Setup category.

Help

Press  +  to view the *Help* menu and print out help pages.

Show Sensor Status (Atria 3100 only)

Press  to display status of sensors.

Inspection at Delivery

Please inspect the Atria for any shipping damage.

- If the Atria was damaged during shipment, contact your shipping agent.
- If an item is missing, contact your local representative or call Customer Service at (800) 777-1777 or (608) 764-1919.

WARNING



Misdiagnosis, equipment damage, and warranty void. Only use approved accessories and cables. Using non-approved accessories or cables may cause increased electromagnetic emissions, damage the Atria, or void the warranty.

General Description

Figure 1-1
Atria 6100
Electrocardiograph

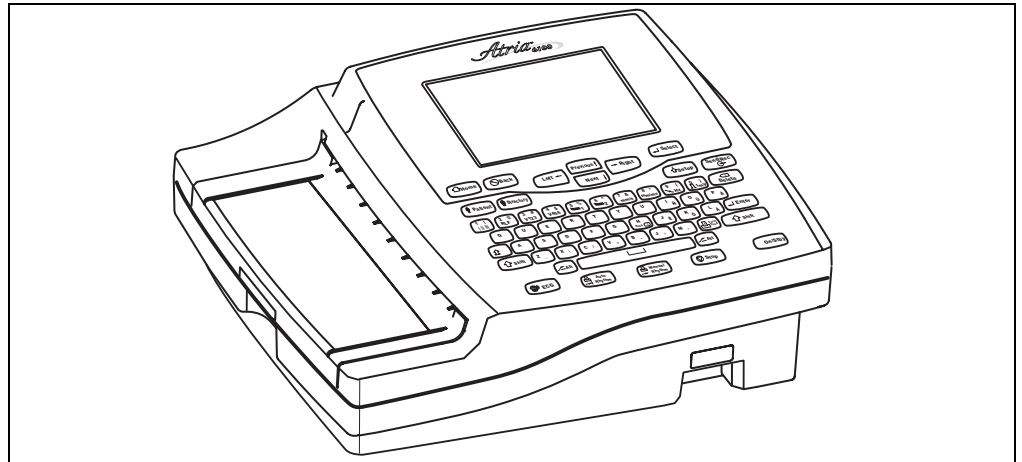
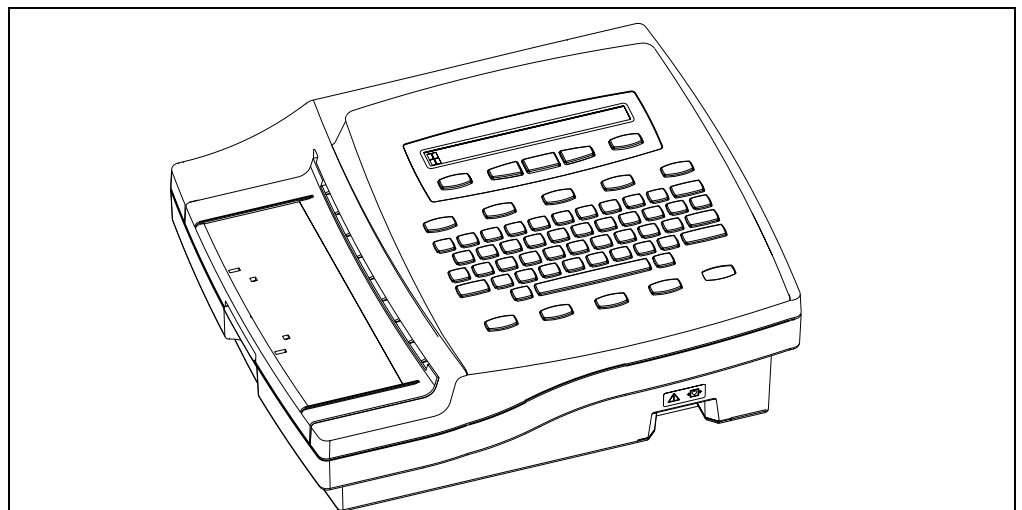

Figure 1-2
Atria 3100
Electrocardiograph



- Battery or AC operation
- Atria 3100: 2 x 40 character backlit LCD screen
Atria 6100: 640 x 480 backlit color LCD screen
- Thermal printer using 8.5 x 11, Z-fold paper
- Manual and automatic rhythm mode
- Standard or Cabrera lead format recording
- Stores (and analyzes on interpretive models) waveforms acquired during automatic mode
- Prints over 300 pages in manual mode at 25 mm/s with fully charged battery
- Battery continuously recharges while connected to AC power (except during printing)
- Selectable patient demographics
- Relative ECG trace gains of x1/2, x1, x2 (corresponds to 5, 10, and 20 mm/mV printer gains)

Interpretive Analysis Program

WARNING



Misdiagnosis. U.S. Federal law restricts this device to sale by or on the order of a physician. The Atria must only be used by qualified operators and any results interpreted by a qualified diagnostician.

The Atria is available with an optional University of Glasgow interpretive analysis program. Features include:

- Factoring in Age, Gender, and Race
More than 500 measurements are factored into each analysis. Criteria for abnormalities include age, race, and gender. Race, for example, is key in identifying hypertrophy and T-wave abnormalities.
- User-selectable QTc Formulas for diagnosis and pharmaceutical studies
To calculate QTc, select from Hodges, Bazett, Fridericia, or Framingham formulas.
- Retrospective Analysis Support
The Atria reanalyzes data after age, gender, race, drug therapy, or clinical classification are changed.

Refer to the ECG Interpretation Criteria Physician's Guide for complete information.

Using Multiple Electrical Apparatus

WARNING

Shock hazard. Connect the Atria only to non-medical equipment compliant with IEC 60950 or 60601-1.



In addition, the enclosure leakage current of non-medical equipment connected to the Atria must not exceed 150µA in fault condition.

If necessary, use an additional isolating transformer or floating power supply to maintain a proper enclosure leakage current and provide additional protection.

WARNING



Patient safety. Non-medical equipment connected to the Atria must not be within the patient's vicinity: 6 feet (1.83 m) beyond the perimeter of the bed, table, or chair, and 7 1/2 feet (2.29 m) above the floor.

WARNING



Misdiagnosis. Electromagnetic interference may cause trace noise or input overload conditions. This may be caused by the presence of strong EMI fields, or generated by RF noise on the line power, or by electronic, surgical, or diathermy instruments in close proximity to the Atria. Position the Atria away from other electrical or electronic equipment, if possible.

If used with, or around, other electrical or electronic equipment, always carefully monitor initial readings to verify normal operation.

The Atria is compliant with IEC 60601-1-2 EMC immunity requirements. Refer to "EMC Declaration Tables" on pg. 11-10.

To prevent excessive patient leakage current ensure all patient equipment meets certified IEC and ANSI/AAMI medical standards.

NOTE: The Atria patient leads are electrically isolated from ground and the device meets IEC and ANSI/AAMI medical standards for leakage current.

Password Protection

The Atria uses password protection to restrict administrative and directory access. For more information on enabling and setting the password, see "Password Protection" on pg. 4-1.

Help Menu

To access the **Help** menu:

1. Press **[ALT] + [H]**.
2. Use the navigation keys to select a topic and then press **[Select]** to print topic information.

NOTE: Help is available at any time except during alphanumeric entry (for example, when entering the patient's name).

Automatic Information Entry

To quickly enter user definable lists such as directory listings and email addresses type in the first few letters. To quickly access Atria menu items use the associated quick key for the item. For example, to select the menu item **Print**, press the letter **[P]** on the keyboard.

Paperless Workflow

Paperless mode requires the following settings:

- Communication options must be installed and configured.
- Set **Auto Print** to OFF.
- Set **Auto Send** to ON.

Refer to “Communications Setup” on pg. 5-1 to configure communication options. Refer to “Sequence” on pg. 4-5 to configure Auto Print and Auto Send.

External Connections

Equipotential Ground

The Atria Electrocardiograph is considered CLASS II (ungrounded) equipment.

The exposed metal on the Atria is not likely to become energized because all the exposed metal is double insulated from the internal live circuitry (i.e., will not become energized under single fault conditions). As a result, it is safer not to connect the exposed metal to the internal chassis or the functional earth of the Atria.

This method of protection is recognized by all national and international consensus standards and safety agencies. Since the exposed metal in the Atria cannot become energized by any fault of the internal live circuitry and cannot become energized as a result of differences in the ground potential (because the exposed metal is not connected to ground via any Protective Earth conductor), then there is no reason to provide voltage equalization.

Therefore, the equipotential ground contact is not connected to the exposed metal.

Input Power



WARNING

Patient shock. The Atria must only be used with a medical grade power cord connected to medical grade AC outlet.



WARNING

Trip hazard. Route all cables away from main work areas to minimize risk of tripping and injury.



WARNING

Shock hazard. Connect the Atria only to non-medical equipment compliant with IEC 60950 or 60601-1.

In addition, the enclosure leakage current of non-medical equipment connected to the Atria must not exceed 150 μ A in fault condition.

If necessary, use an additional isolating transformer or floating power supply to maintain a proper enclosure leakage current and provide additional protection.

WARNING



Misdiagnosis. Using unshielded or excessively long cables may cause or increase susceptibility to electromagnetic interference.

Always use the shortest possible shielded cables.

Caution



Equipment damage. The Atria must be operated only at the line voltage and frequency specified on the external medical grade power supply (part number: 010-1684-00).

The input power cable includes a 3-conductor, medical grade power cable. Using the two power cables supplied, connect line power, in the following order:

1. Connect the external power supply (part number: 010-1684-00) to the External Power Connector (labeled C, below) on the back of the Atria.
2. Connect the AC power cable to the external power supply.
3. Connect the AC power cable to a properly grounded, medical grade wall outlet.

Figure 2-1
Back Panel

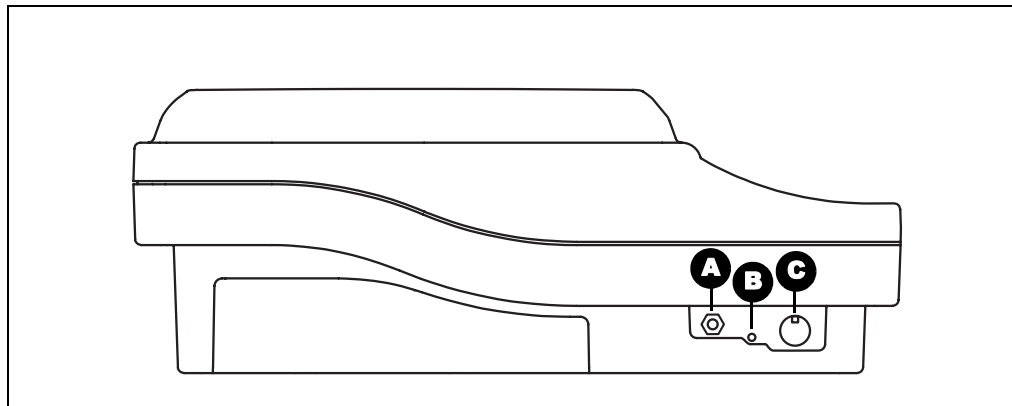

| Key | | |
|----------|---------------------------------|---|
| A | Equipotential grounding | Connect equipotential ground cable here. (See “Equipotential Ground” on pg. 2-1.) |
| B | Power indicator | The green LED indicates the Atria is connected to AC power. |
| C | External power connector | Connect cable from power external power supply here. NOTE: The Atria does not have an AC power switch. To shut off AC power, unplug the Atria from the AC outlet. |

NOTE: For communication connections refer to “Communications Setup” on pg. 5-1.

Patient Cable

Figure 2-2
Front View

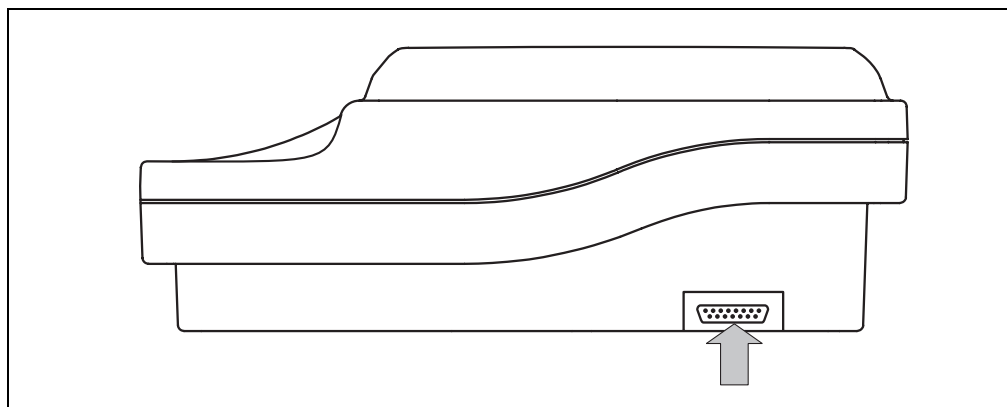

Connect the patient cable via connector on the front of the Atria.

Ensure the connector on the cable is arrow-side-up then firmly push the connector until the arrow point is aligned with the edge of the Atria.

Powering the Atria On and Off

Power On

Press **[On/Stby]** to power on the Atria. The Atria performs self-tests and displays the following:

- Current date and time
- Self-test errors

After completing self-tests, the Atria displays the **Home** screen.

Standby Mode

The Atria must be connected to AC power to go into Standby mode. At any time during operation, press **[On/Stby]**.

NOTE: The internal battery charges in Standby mode.

Power Off

To power off the Atria completely, disconnect the AC power cord and then press **[On/Stby]**.

The automatic power down feature may be temporarily turned off by changing the battery saver setting. For more information, see “Battery Saver Mode” on pg. 4-14.

NOTE: Automatic power down is disabled when the Atria is connected to a patient.

Power Indicator

A green light on the back of the Atria (see Figure 2-1 on pg. 2-2) is on whenever the Atria is receiving power from the external power source.

Charging the Battery



Caution

Data loss. The battery pack must be installed at all times for proper operation.

During normal operation, the following power indications are displayed:

| Display | Description | Action |
|-------------------|---|---|
| AC | Indicates the Atria is connected to AC power. | none |
| Bat | Indicates the Atria is not connected to AC power and is running on the battery. | none |
| Low | Indicates the Atria is running on battery power and less than 15 minutes of operating time remain. The Atria also beeps every 30 seconds as an audible low battery warning. | When Low displays, immediately connect the Atria to AC power to recharge the battery and prevent operation interruption. |
| Power down | Indicates the battery no longer has enough power to maintain normal operation and shuts off 5 seconds after the message is displayed. | Connect the Atria to AC power to resume operation. |

Loading Recording Paper

Caution



Warranty void. Using unapproved recording paper may damage the Atria and void the warranty. The Atria is intended for use only with approved ECG supplies.

Use only the following approved, thermal ECG paper:

- Assurance™, permanent trace, Z-fold. Guaranteed image integrity for 25 years when stored per manufacturer's specifications.
- HeartLine™, standard trace, Z-fold. Guaranteed image integrity 5 years when stored per manufacturer's specifications.

Loading Paper: Fixed Paper Door Models

Figure 2-3
Atria Paper Tray
Removed

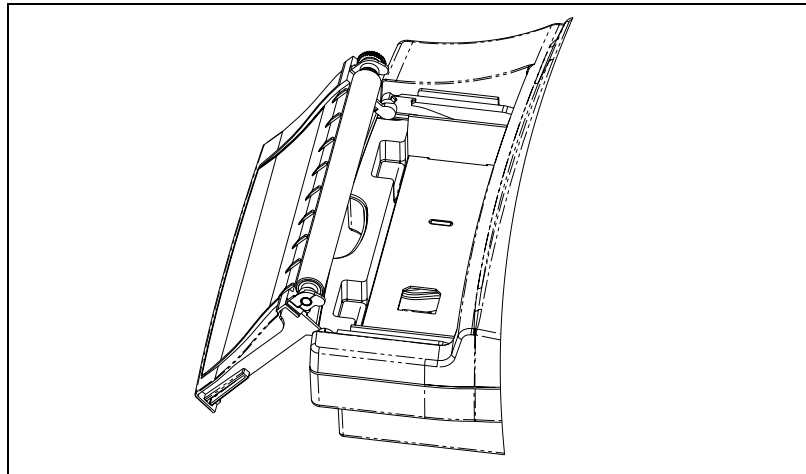

To load paper:

1. Open the paper tray door on the left side of the unit. With your left hand, firmly pull the door to the left until it opens.

The door pivots down when fully opened.

DO NOT ATTEMPT TO REMOVE THE DOOR FROM THE UNIT.

2. Place a stack of paper in the compartment so that the black queue mark on the lower left corner of the paper is visible.
3. With your right hand, lift the top sheet of paper.
4. Lift the door and slide the door back into the unit.

DO NOT INSERT THE DOOR AT AN ANGLE.

5. Pull the paper out so it covers the door.

IMPORTANT: THE EDGES OF THE PAPER MUST BE CENTERED BETWEEN AND PARALLEL TO THE DOOR GUIDES ON THE PAPER DOOR.

6. Slide the door firmly until it snaps into place.
7. Press **[On/Standby]** to power on the unit and then wait until the unit beeps.
8. Press **[Form Feed]** three to five times.

Ensure the paper tracking is straight. If the paper is not straight, repeat this procedure from Step 1, until the paper is straight.

9. Tear off extra pages at the perforation.

NOTE: You must select the correct paper type. The default paper setting is **Assurance**. If using HeartLine paper, see “Paper Type” on pg. 4-13 to change the setting.

Loading Paper: Removable Door Models

Figure 2-4
Atria Paper Tray
Removed

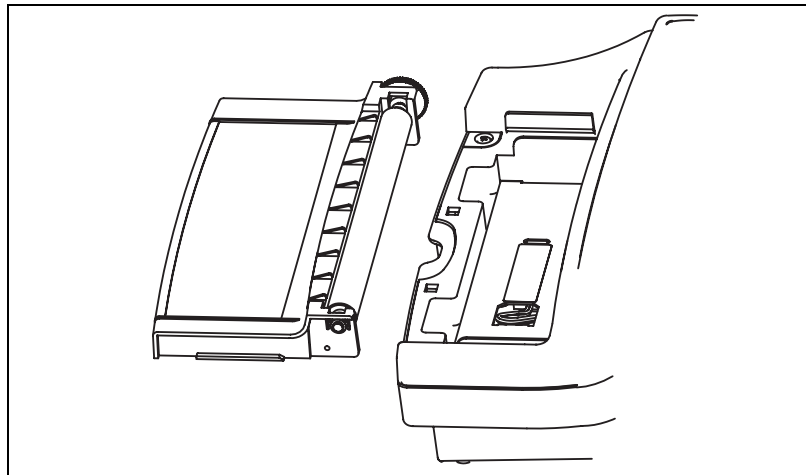

To load paper:

1. Remove the paper tray door on the left side of the Atria.
 - a. Squeeze paper door lever, in the middle of tray, until it clicks.
 - b. Pull out door completely, taking care not to drop the door.
2. Place a stack of paper into the compartment so that the black queue mark on the lower left corner of the paper is visible.
3. With your right hand, lift the top sheet of paper.
4. Align the door on the track, and slide the door most of the way into the unit. **DO NOT INSERT THE DOOR AT AN ANGLE.**

5. Pull the paper so it covers the door.

NOTE: The edges of the paper must be parallel to the lines printed on the paper door.

6. Slide the door into place until it clicks.
7. Press **[On/Standby]** to power on the unit and then wait until the unit beeps.
8. Press **[Form Feed]** three to five times. Ensure the paper is tracking straight. If the paper is not straight:
 - Press **[Form Feed]** a couple more times, until the paper tracking is straight.
 - If necessary, repeat this procedure from Step 1, until the paper is straight.
9. Tear off extra pages at the perforation.

NOTE: You must select the correct paper type. The default paper setting is **Assurance**. If using HeartLine paper, see “Paper Type” on pg. 4-13 to change the setting.

Chapter 3 *User Interface*

The Atria user interface consists of an LCD display and keyboard. There are two versions of the Atria keyboard. Both versions are illustrated below.

Figure 3-1
User Interface
(Keyboard Version 1)

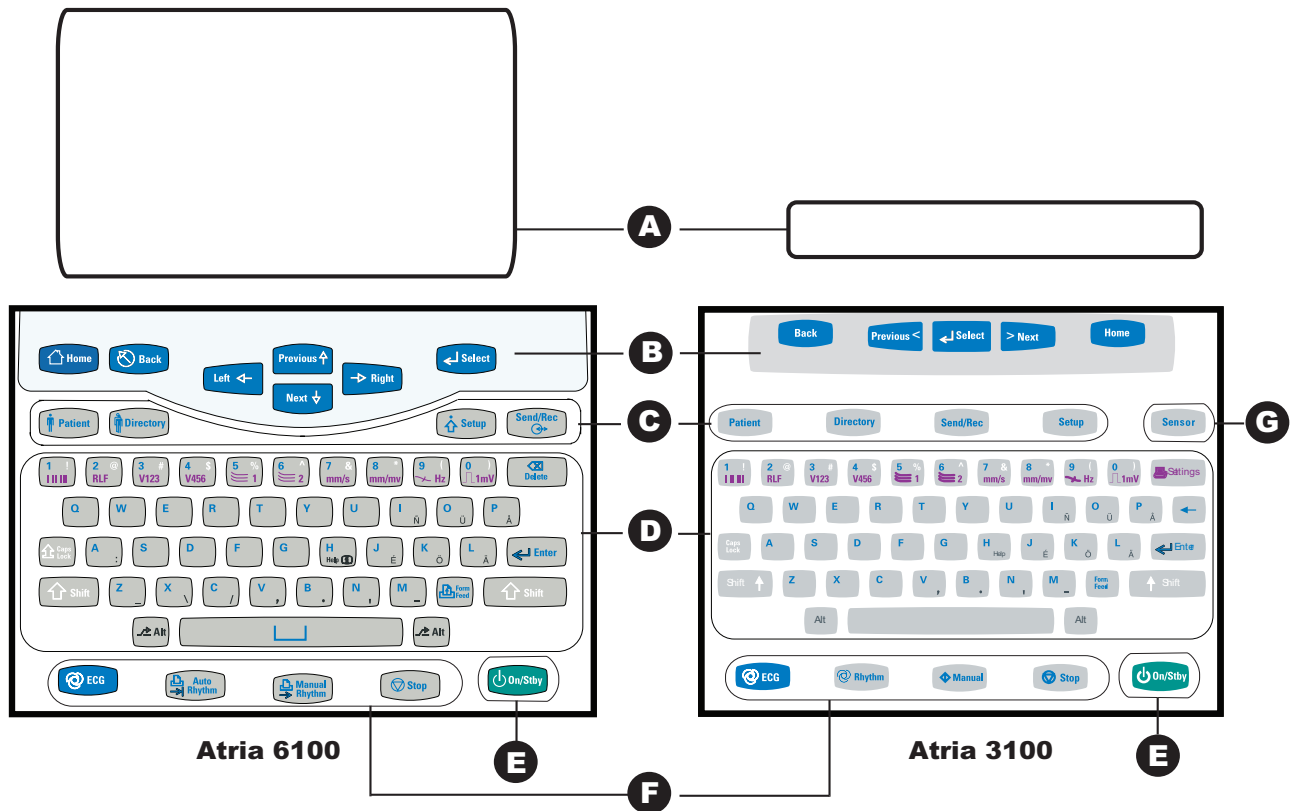
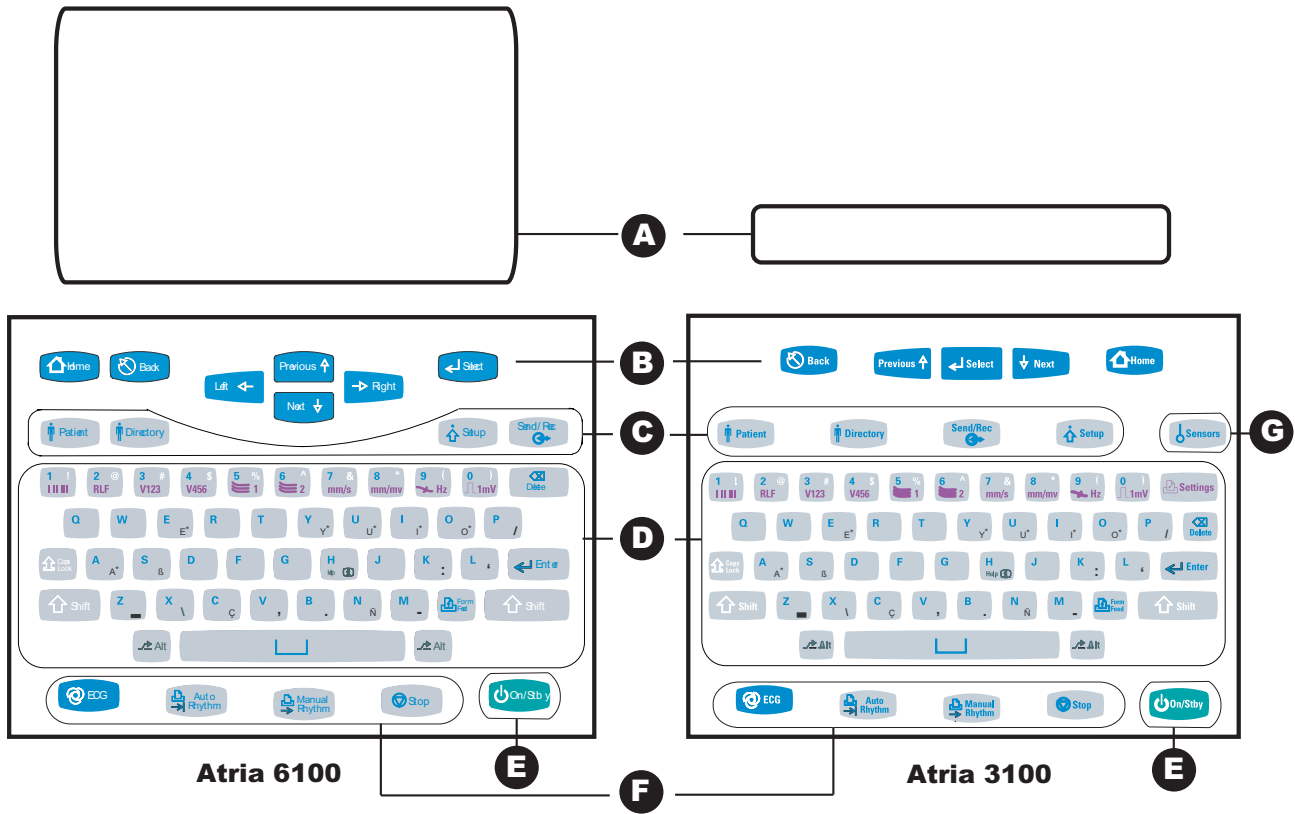

Figure 3-2
User Interface
(Keyboard Version 2)



| Key | |
|-----|---|
| A | Display (Atria 6100: Includes ECG Settings) |
| B | Navigation keys |
| C | Menus |
| D | Keyboard |
| E | Power |
| F | ECG Keys |
| G | Sensor (Atria 3100 only) |

Keyboard

The following table describes the Atria keys.

NOTE: Not all key functions are available on every screen.

| Function | Key | Description |
|--|------------------------------|---|
| Main Power | [On/Stby] | Powers on the Atria When the Atria is on, press this key to: <ul style="list-style-type: none"> • Power off the Atria when operating on battery power. • Go to Standby when connected to external power (The battery continues to charge.) |
| User At the Home screen | [Alt]+ [1] or [2] | Select either User 1 or User 2. See “Multiple Users” on pg. 4-1. |
| ECG Press [Stop] at any time stop printing and return to the Home screen | [ECG] | Acquire and print a 12-lead ECG (a series of reports using pre-programmed lead sequences and settings). |
| | [Auto Rhythm] | Print an auto rhythm report (a rhythm strip with a pre-selected number of pages using the leads currently selected). |
| | [Manual Rhythm] | Print a manual rhythm report (a continuous rhythm strip of the leads currently selected). This report runs until the [Stop] key is pressed. |
| ECG Settings (Number Keys) | [1], [2], [3], or [4] | To select pre-programmed lead triplets. The leads are printed on manual rhythm and auto rhythm reports. |
| | [5] or [6] | Custom lead 1 or Custom lead 2 to select user-defined leads. The leads are printed on manual rhythm and auto rhythm reports. See “Custom Lead Settings” on pg. 4-9 for setup information. |
| | [7] | Select paper speed (12.5, 25, or 50 mm/sec). |
| | [8] | Select ECG gain (5 mm/mV, 10 mm/mV, 20 mm/mV; L10, C5 mm/mV; or L20, C10 mm/mV). |
| | [9] | Toggles the upper ECG filter frequency response (40 or 150 Hz). |
| | [0] | For a 1 mV calibration pulse on auto or manual rhythm printouts. |

| Function | Key | Description |
|--------------------|------------------------------------|---|
| Navigation | [Back] | Return to the previous menu or display |
| | [Select] | Accept or edit the current selection |
| | [Previous]/[Next] | Scroll up or down |
| | [Left]/[Right] (Atria 6100) | Move cursor to left or right |
| | [Home] | Go to the Home (or main) display |
| Status | [Sensor] (Atria 3100) | Display Sensor status |
| Menu | [Patient] | Select a patient (current, new, or saved) |
| | [Directory] | Access stored patient records |
| | [Send/Rec] | Communication options |
| | [Setup] | Configure settings |
| Help | [Alt] + [H] | Help menu |
| Main Keyboard | [A] through [Z] | Alpha characters |
| | [1] through [0] | Numeric characters |
| | [Delete] | Delete one character |
| | [Enter] | Accept or edit the current selection |
| | [Form Feed] | Advance one sheet of paper |
| Special Characters | [Shift] + [1] | ! (exclamation point) |
| | [Shift] + [2] | @ (at sign) |
| | [Shift] + [3] | # (pound sign) |
| | [Shift] + [4] | \$ (dollar sign) |
| | [Shift] + [5] | % (percent) |
| | [Shift] + [6] | ^ (carrot) |
| | [Shift] + [7] | & (ampersand) |
| | [Shift] + [8] | * (asterisk) |
| | [Shift] + [9] | ((left parenthesis) |
| | [Shift] + [0] |) (right parenthesis) |

NOTE: Do not enter European (accented) characters in any password for this device.

| Function | Key | Description |
|--------------------|---|--|
| Special Characters | [Alt] + [E] (Keyboard V2) | Hold down [Alt] then press [E] to step through the settings: è (e grave) é (e acute) ê (e circumflex) ë (e umlaut) |
| | [Alt] + [Shift] + [E] (Keyboard V2) | Hold down [Alt] and [Shift] then press [E] to step through the settings: È (E grave) É (E acute) Ê (E circumflex) Ë (E umlaut) |
| | [Alt] + [Y] (Keyboard V2) | Hold down [Alt] then press [Y] to step through the settings: ý (y acute) ÿ (y umlaut) |
| | [Alt] + [Shift] + [Y] (Keyboard V2) | Ÿ (Y acute) |
| | [Alt] + [U] (Keyboard V2) | Hold down [Alt] then press [U] to step through the settings: ù (u grave) ú (u acute) û (u circumflex) ü (u umlaut) |
| | [Alt] + [Shift] + [U] (Keyboard V2) | Hold down [Alt] and [Shift] then press [U] to step through the settings: Û (U grave) Ú (U acute) Û (U circumflex) Ü (U umlaut) |
| | [Alt] + [O] (Keyboard V2) | Hold down [Alt] then press [O] to step through the settings: ò (o grave) ó (o acute) ô (o circumflex) õ (o tilde) ö (o umlaut) |
| | [Alt] + [Shift] + [O] (Keyboard V2) | Hold down [Alt] and [Shift] then press [U] to step through the settings: Ò (O grave) Ó (O acute) Ô (O circumflex) Õ (O tilde) Ö (O umlaut) |
| | [Alt] + [P] (Keyboard V2) | / (forward slash) |
| | [Alt] + [A] (Keyboard V1) | : (colon) |

| Function | Key | Description |
|--------------------|---|--|
| Special Characters | [Alt] + [A] (Keyboard V2) | Hold down [Alt] then press [A] to step through the settings: à (a grave) á (a acute) â (a circumflex) ã (a tilde) ä (a umlaut) å (a ring) |
| | [Alt] + [Shift] + [A] (Keyboard V2) | Hold down [Alt] and [Shift] then press [A] to step through the settings: À (A grave) Á (A acute) Â (A circumflex) Ã (A tilde) Ä (A umlaut) Å (A ring) |
| | [Alt] + [S] | ß (German double s) |
| | [Alt] + [K] (Keyboard V2) | : (colon) |
| | [Alt] + [L] (Keyboard V2) | ' (single quote mark) |
| | [Alt] + [Shift] + [L] (Keyboard V2) | " (double quote mark) |
| | [Alt] + [Z] | _ (underscore) |
| | [Alt] + [X] | \ (back slash) |
| | [Alt] + [C] (Keyboard V1) | / (forward slash) |
| | [Alt] + [C] (Keyboard V2) | Ç (c cedilla) |
| | [Alt] + [V] | , (comma) |
| | [Alt] + [Shift] + [V] | < (less than) |
| | [Alt] + [B] | . (period) |
| | [Alt] + [Shift] + [B] | > (greater than) |
| | [Alt] + [N] (Keyboard V1) | ' (single quote mark) |
| | [Alt] + [N] (Keyboard V2) | ñ (n tilde) |
| | [Alt] + [Shift] + [N] (Keyboard V2) | Ñ (N tilde) |
| | [Alt] + [M] | - (dash) |

Display Atria 6100

The Atria 6100 display has two types of screens, the **Home** screen and various menu screens.

WARNING



Misdiagnosis. Do not use Atria screen images for diagnosis. The screen image is provided for reference only. Use the printout to ensure accurate diagnosis.

Atria 6100 Home Screen

After the Atria is powered up it performs self-tests, and then displays the **Home** screen.

NOTE: Press **[Home]** from most menu screens to return to the **Home** screen.

Figure 3-3
Atria 6100
Home Screen

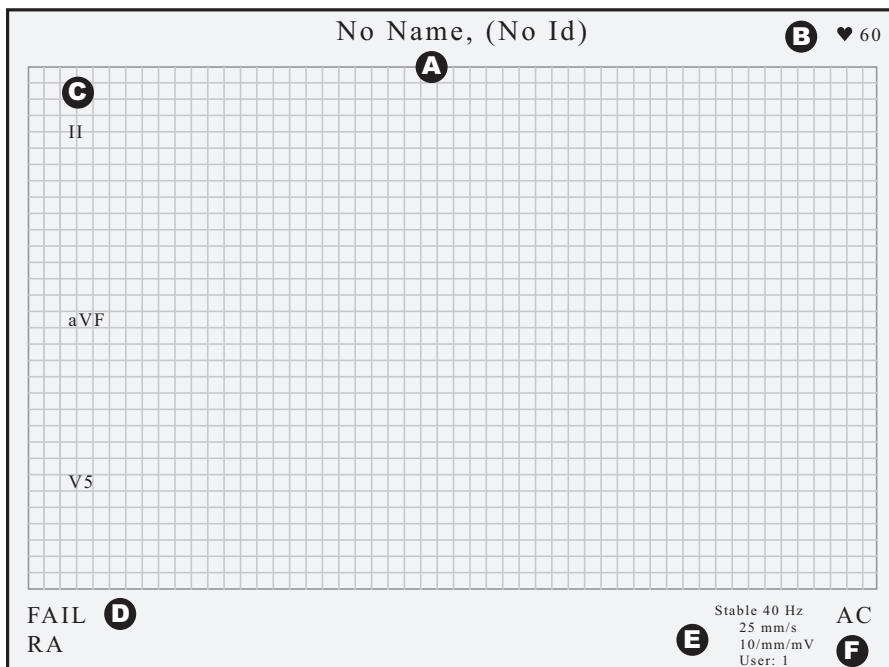

| Label | Text | Description |
|-------|-------------|--|
| A | Name and ID | Displays name and ID number for current patient. (If there is not a current patient, this field displays as No Name, (No Id) , and pressing ECG results in STAT ECG.) |
| B | Heart rate | Indicates heart rate. |

| Label | Text | Description |
|----------|------------------------------------|--|
| C | Selected lead configuration | Figure above shows default. Press keys 1 through 6 for alternate configurations. |
| D | Sensor status | Indicates signal quality. If signal quality is bad, the display indicates the problem (Fail, Drift, or Noise) and shows which sensor is affected. |
| E | Settings Information | Displays user settings. Press the key indicated to change: <ul style="list-style-type: none"> • [9] - Stable 40 Hz or 150 Hz • [7] - 25 mm/s, 50 mm/s, 12.5 mm/s • [8] - 10 mm/mV, 20 mm/mV, L=10 C=5, L=20 C=10, 5 mm/mV • [Alt] + [1] User 1 settings • [Alt] + [2] User 2 settings |
| F | Power Status | Indicates power source and status. AC - the Atria is connected to external power. Low - low battery Bat - the Atria is powered by the battery |

Atria 6100 Menu Screens

Use the Menu keys to go to one of the main menus:

- **[Patient]** — Enter patient demographics
- **[Directory]** — Display the patient directory
- **[Setup]** — Change system settings
- **[Send/Rec]** — Communications options

NOTE: Press **[ALT] + [H]** to access the **Help** menu.

Each menu or list item has an associated hot key. The hot key is indicated by the letter underlined on the list item. For example, the list item **Years** may be selected by pressing **[Y]**.

Some List fields have default settings. For example, the default setting for **Age Format** is **Years**.

The example below shows how to navigate a menu screen to enter patient demographics.

Figure 3-4
Atria 6100
Patient Source
Selection Menu

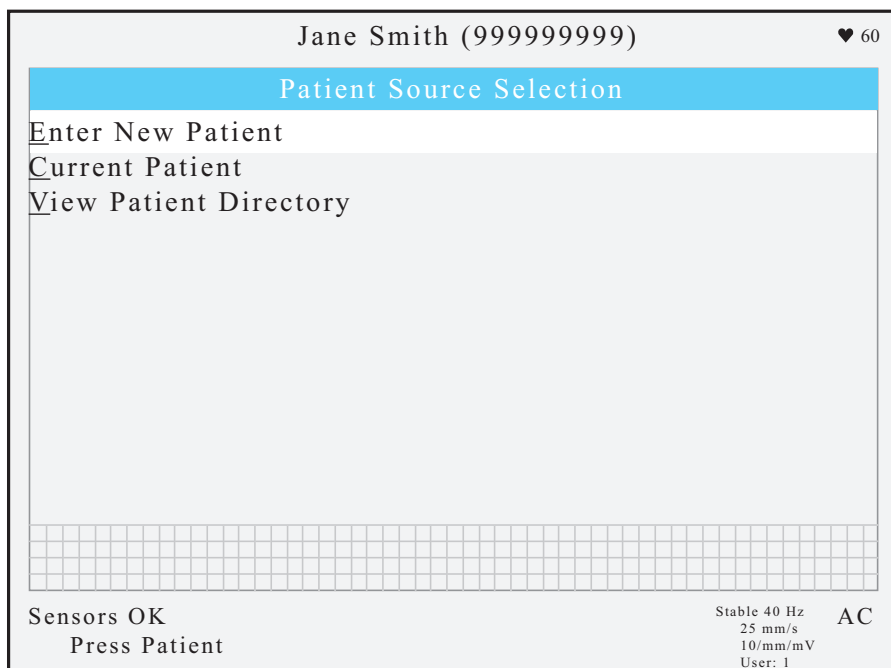

1. If the **Home** screen is not displayed, press **[Home]**.
2. Press **[Patient]**.
3. Press **[Select]**. The **Enter/Edit Patient ID** entry field displays.
4. Enter patient information and press **[Select]**. The next entry field automatically displays.

NOTE: To review or change an entry, press the **[Back]** key to go to the **Select Field to Edit** menu. Use **[Previous]** or **[Next]** and to scroll to a field and then press **[Select]** to enter or change the information.

5. When all demographic information is entered, press **[Home]** to return to the **Home** screen.

Display Atria 3100

The Atria 3100 display has two types of screens, the **Home** screen and various menu screens.

Atria 3100 Home Screen

After the Atria is powered up it performs self-tests, and then displays the **Home** screen.

NOTE: Press **[Home]** from most menu screens to return to the **Home** screen.

Figure 3-5
Atria 3100
Home Screen



| Label | Text | Description |
|-------|------------------------------------|--|
| A | Name and ID | Displays name and ID number for current patient. (If there is not a current patient, this field displays as No Name, (No Id) , and pressing ECG results in STAT ECG.) |
| B | Sensor status or heart rate | Indicates signal quality or heart rate. If sensors are not ok, the display indicates the problem (Fail, Drift, or Noise) and shows which sensor is affected. If sensors are ok, then heart rate is indicated here. |
| C | Suggested next step | Directs the user to the next logical step. |
| D | Power Status | Indicates power source and status. AC - unit is connected to external power. Low - low battery Bat - unit is powered by the battery |

Atria 3100 Menu Screens

Use the Menu keys to go to one of the main menus:

- **[Patient]** — Enter patient demographics
- **[Directory]** — Display the patient directory
- **[Setup]** — Change system settings
- **[Send/Rec]** — Communications options

NOTE: Press **[ALT] + [H]** to access the **Help** menu.

Some List fields have default settings. For example, the default setting for **Age Format** is **Years**.

The example below shows how to navigate a menu screen to enter patient demographics.

Figure 3-6
Atria 3100
Patient Source
Selection Menu

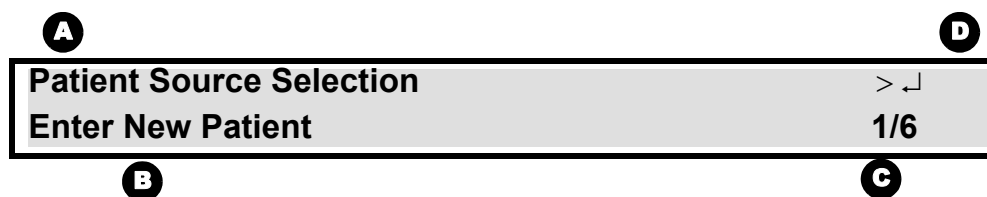

| Label | Text | Description |
|----------|-------------------------------------|---|
| A | Menu Title | Displays the menu title of the current menu or the menu selection. |
| B | Menu Items | Displays the sub-menu or the entry field for the menu selection. |
| C | Current Page/Available Pages | Displays the current page followed by the total number of pages in the current menu. |
| D | Navigation | Displays the acceptable navigation selections < (Previous) > (Next) <-> (Select) |

1. If the **Home** screen is not displayed, press **[Home]**.
2. Press **[Patient]**.
3. Press **[Select]** to display the **Patient ID** entry field.
4. Enter patient information and press **[Select]**. The next entry field automatically displays.

NOTE: To review or change an entry, press the **[Back]** key or use **[Previous]** or **[Next]** and to scroll to a field and then press **[Select]** to enter or change the information.

5. When all demographic information is entered, press **[Home]** to return to the **Home** screen.

Overview

The **Settings** menu sets defaults for each use. For example, to default to a gain of 5 mm/mV, press **[Setup]** then select **Waveform Preferences > Gain > 5 mm/mV**. For each use, the gain will default to 5 mm/mV.

Multiple Users

Most Atria settings (except for system settings and communication settings) can be configured for either User 1 or User 2:

For example, if the Atria used by two different doctors:

- Dr. Miller: Brief format interpretation, two copies of the ECG, ECG speed of 12.5 mm/sec and gain of 5 mm/mV.

Select User 1 and enter Dr. Miller's preferences.

- Dr. Carrera prefers the Full format interpretation, one copy of the ECG, ECG speed of 25 mm/sec and gain of 10 mm/mV.

Select User 2 and enter Dr. Carrera's preferences.

1. To determine the current user:
 - Atria 3100: Press **[Setup]**. The current user displays to the right of the menu title.
 - Atria 6100: The current user is shown in the lower right corner of the display.
2. Press **[Home]** and then press **[Alt] + [1]** to select User 1 or press **[Home]** and then press **[Alt] + [2]** to select User 2.

The Atria requires a restart to change users.

3. Press any key to restart.

Password Protection

Use a password to prevent unauthorized settings changes.

Refer to either:

- "Administrative Password" on pg. 4-13.
- "Directory Password" on pg. 4-14.

Setup Menu

The **Setup** menu includes the following items.

- **Print Setup Report**
- **ECG**
- **Waveform Preferences**
- **Rhythm**
- **Patient**
- **Directory**
- **System**
- **Send Receive**
- **Printer**
- **Print Communication Log**
- **Print System Statistics**
- **Product Keys**
- **Service Functions**

To go to the **Setup** menu, press **[Home]** and then press **[Setup]**.

NOTE: Configure settings for either User 1 or User 2.

Print Setup Report

Prints all the settings for the current user.

ECG Settings

The **ECG** menu includes the following items.

- **Report Format**
- **Sequence**
- **Interpretation Preferences**

Report Format

Displays up to three rhythm lead selections based on the 12-lead format selected.

| ECG Menu Items: Report Format | Description | Selections |
|--|---|---|
| Report Format (12-lead) | <p>Select the format to use for the report generated by pressing the [ECG] button.</p> <p>For sample printouts, see Chapter 9.</p> <ul style="list-style-type: none"> • STANDARD 4 CHANNEL—3 channel ECG with 1 rhythm lead • STANDARD 3 CHANNEL • STANDARD 3 + 3—3 channel ECG with 3 rhythm leads • STANDARD 6 CH 5S/LD—5 seconds per lead, 1 page total • STANDARD 6 CH 10S/LD—10 seconds per lead, 2 pages total • CABRERA 4 CHANNEL—1 rhythm lead • CABRERA 3 CHANNEL • CABRERA 3 + 3—3 channel ECG with 3 rhythm leads • CABRERA 6 CH 5S/LD— 5 seconds per lead, 1 page total • CABRERA 6 CH 10S/LD—10 seconds per lead, 2 pages total | STANDARD 4 CHANNEL STANDARD 3 CHANNEL STANDARD 3 + 3 STANDARD 6 CH 5S/LD STANDARD 6 CH 10S/LD CABRERA 4 CHANNEL CABRERA 3 CHANNEL CABRERA 3 + 3 CABRERA 6 CH 5S/LD CABRERA 6 CH 10S/LD |
| Rhythm Lead Channel 1 | <p>This selection displays for the following formats only:</p> <ul style="list-style-type: none"> • 4-channel • 3+3 format. <p>The rhythm lead displays at the bottom of the printout.</p> | LEAD I LEAD II LEAD III aVR aVL aVF V1 V2 V3 V4 V5 V6 -aVR |

| ECG | | |
|--------------------------------------|--|---|
| Menu Items: Report Format | Description | Selections |
| Rhythm Lead Channel 2 | This selection displays for the following formats only: <ul style="list-style-type: none"> • 3+3 format Rhythm leads display at the bottom of the printout. | LEAD I LEAD II LEAD III aVR aVL aVF V1 V2 V3 V4 V5 V6 -aVR |
| Rhythm Lead Channel 3 | This selection displays for the following formats only: <ul style="list-style-type: none"> • 3+3 format Rhythm leads display at the bottom of the printout. | LEAD I LEAD II LEAD III aVR aVL aVF V1 V2 V3 V4 V5 V6 -aVR |
| Print Rhythm Page | Enable a separate 10-second rhythm report as part of the ECG report. The rhythm page prints 10 seconds of all 12 leads. | 12 Leads at 25 mm/s 12 Leads at 50 mm/s OFF |
| Print Median Complex Page | For interpretive units only. Enable the Median Complex printout as part of the ECG report. | ON OFF |
| Number of Copies | Enter the number of report copies to print in addition to the automatic printout. Valid entries are 0 through 5. | [text entry] |

Sequence

Configure automatic functions.

| ECG Menu Items: Sequence | Description | Selections |
|-----------------------------|--|---|
| Wait for good data | <p>When enabled (ON), the system delays the ECG reports until the system has collected ten seconds of low noise waveform data (all electrodes must be connected). To force an immediate report, press [ECG] again when the system displays Waiting for Good Data. The report includes “Warning: Data quality may affect interpretation.”</p> <p>When disabled (OFF), the ECG report starts after 10 seconds of ECG waveform data, regardless of quality. No warning message is included.</p> <p>NOTE: The ECG report does not include waveform data for disconnected electrodes. Leads with disconnected electrodes are not used in the ECG analysis.</p> | <p>ON OFF</p> |
| Auto Print | <p>Sets ECG report print options (for thermal, plain paper, or both).</p> <ul style="list-style-type: none"> • ON—automatically print • Prompt—prompt before printing • OFF—automatically bypass printing | <p>ON Prompt OFF</p> |
| Auto Save | <p>Sets ECG reports save options.</p> <ul style="list-style-type: none"> • ON—automatically save • Prompt—prompt before saving | <p>ON Prompt</p> |
| Auto Send | <p>Requires the Communications option. See “Communications Setup” on pg. 5-1 and “Setup EMR Communications” on pg. 5-12.</p> <ul style="list-style-type: none"> • ON—automatically send • Prompt—prompt before sending • OFF—do not automatically send | <p>ON Prompt OFF</p> |
| Auto Email | <p>Requires the Communications option. Also requires, an SMTP server address, and an email address. See “Communications Setup” on pg. 5-1 and “Setup Email” on pg. 5-10.</p> <p>NOTE: By default, automatic email uses the first email address.</p> <ul style="list-style-type: none"> • ON—automatically email • Prompt—prompt before sending email • OFF—do not automatically send email | <p>ON Prompt OFF</p> |

Interpretation Preferences

Settings below are available only on interpretive units.

| ECG Menu Items: Interpretation Preferences | Description | Selections |
|---|--|--|
| Analysis Statements | Select the format for the Analysis Statements <ul style="list-style-type: none"> • BRIEF—Displays minimal explanations in mixed case (for example, “Normal ECG”) • FULL—Displays longer explanations in upper case (for example, “NORMAL ECG”). Also includes reason statements. | BRIEF FULL |
| Print Interpretation on Original | Enables analysis statements on the original copy of the ECG report printout. | ON OFF |
| Print Interpretation on Copies | Enables analysis statements on additional copies of the printed ECG report. | ON OFF |
| Bradycardia Limit | Heart rates below the set adult rate limit are labeled Bradycardia. Rate limit range is 41 to 69. | [text entry] |
| Tachycardia Limit | Heart rates above the set adult rate limit are labeled Tachycardia. Rate limit range is 81 to 129. NOTE: Tachycardia limits are age dependent for neonatal and pediatric patients. For neonatal and pediatric patients, the Atria interpretive software disregards the Tachycardia Limit setting and uses predefined limits (between 100 and 180, depending upon age). For more information see Chapter 3, “Heart Rate”, in the Physician’s Guide. | [text entry] |
| QTc Formula | Select the QTc formula (it displays at the bottom of the ECG printout): For additional information on the QTc formulas, see “QT Interval” on page 4-3 of the Physician’s Guide. | Hodges (Default) Bazett Fridericia Framingham |

Waveform Preferences

Configure the appearance of the waveform settings at power on.

| Waveform Preferences Menu Items | Description | Selections |
|---------------------------------|--|--|
| Speed | Set the chart paper speed. | 12.5 mm/s 25 mm/s 50 mm/s |
| Gain | Set the waveform gain. <ul style="list-style-type: none"> • 5 mm/mV • 10 mm/mV (Default) • 20 mm/mV • L=10 C=5—standard gain for limb leads, half the standard gain for chest leads • L=20 C=10—double the standard gain for limb leads, standard gain for chest leads | 5 mm/mV 10 mm/mV 20 mm/mV L=10 C=5 L=20 C=10 |
| Artifact Filter | Select the upper frequency response. <ul style="list-style-type: none"> • 150 Hz—provides the most accurate recording and should be used when little or no noise is present. <p>NOTE: The American Heart Association's 1990 Recommendations for Standardization and Specifications in Automated Electrocardiography: Bandwidth and Signal Processing pertaining to high-frequency response for both adult and pediatric recordings are met when using the 150 Hz setting.</p> <ul style="list-style-type: none"> • 40 Hz—reduces muscle artifact and high frequency environmental noise for a smoother trace but less fine detail. <p>This filter setting applies only to the printed report and displayed ECG. The data analyzed by the measurement and interpretation software is not affected.</p> <p>For additional information, see "40 Hz Artifact Filter" on pg. 11-9.</p> | 150 Hz 40 Hz |

| Waveform Preferences Menu Items | Description | Selections |
|--|--|---|
| Baseline Filter | <p>Select the low frequency response</p> <ul style="list-style-type: none"> • STABLE Baseline—Baseline Stabilization Filter. Suppresses most baseline wander interference while providing an accurate ECG reproduction (no distortion of the ST segment.) This filter applies to the printed report, displayed ECG, and the data analyzed. • 0.05 Hz—Use the 0.05 Hz filter when signal delay is unacceptable. <p>NOTE: Cardiac Science Corp. recommends use of the STABLE Baseline filter except when a signal delay of 1.5 seconds is unacceptable.</p> <p>NOTE: Both the 0.05 Hz and STABLE Baseline selections meet the American Heart Association's 1990 Recommendations for Standardization and Specifications in Automated Electrocardiography: Bandwidth and Signal Processing) pertaining to low-frequency response in electrocardiography.</p> | <p>STABLE Baseline 0.05 Hz</p> |
| Line Filter | <p>Filter electrical interference from AC line voltage.</p> <p>NOTE: The line filter should be on. Turn off only if necessary.</p> | <p>ON OFF</p> |
| Pacer Enhancement | <p>Displays pacemaker signals as artificial spikes on the display and printouts (the positive spike is at least 10 mm).</p> | <p>ON OFF</p> |
| Lead Group | <p>Select the lead triplet. The selected leads print on the manual rhythm and the auto rhythm reports.</p> | <p>I II III RVF V123 V456 Custom 1 Custom 2</p> |

Rhythm

To print rhythm reports for the selected lead group ([1] through [4] for presets or [5] and [6] for custom settings):

- Press **[Manual Rhythm]** or **[Auto Rhythm]**.

The **Rhythm** menu includes the following items:

- **Auto Rhythm Pages**
- **Setup Custom 1**
- **Setup Custom 2**

Setup Auto Rhythm

Enter the number of pages for an Auto Rhythm Report (1 to 10).

Custom Lead Settings

The Atria has two custom lead configurations:

- Custom 1
- Custom 2

Both configurations are available when automatic rhythm or manual rhythm is selected.

WARNING



False readings. The lead status check does not detect lead reversals. Always ensure the lead placement used is for the lead configuration selected.

| Rhythm Menu Items: Setup Custom 1 (and 2) | Description | Selections |
|--|---|--|
| Set Up Custom 1 (or 2) | <p>The custom lead format used for: [Auto Rhythm] or [Manual Rhythm] Custom 1 is the default displayed lead set.</p> <p>NOTE: Selecting the ALTERNATE CHEST LEADS format will cause all standard ECG printouts to include alternate chest lead settings until another custom lead format is selected (i.e., press any of the keys [1] through [4]).</p> | <p>CUSTOM 3-CHANNEL STANDARD LIMB 6-CHANNEL STANDARD PRECORDIAL 6-CHANNEL CUSTOM 6-CHANNEL STANDARD 12- CHANNEL CABRERA LIMB 1-3 CABRERA LIMB 4-6 CABRERA 6-CHANNEL CABRERA 12-CHANNEL ALTERNATE CHEST LEADS</p> |
| Channels 1 through 6 | <p>For CUSTOM 3-CHANNEL format, select leads for channels 1 through 3.</p> <p>For CUSTOM 6-CHANNEL format, select leads for channels 1 through 6.</p> | <p>LEAD I LEAD II LEAD III aVR aVL aVF V1 V2 V3 V4 V5 V6 -aVR</p> |

| Rhythm Menu Items: Setup Custom 1 (and 2) | Description | Selections |
|--|--|---|
| Channels 7 through 12 | For ALTERNATE CHEST LEAD (3X4, 1R) format select leads for channels 7 through 12. | V1 V2 V3 V4 V5 V6 V7 V8 V9 V2R V3R V4R V5R V6R V7R V8R V9R |

Patient Settings

The **Patient** menu sets the patient demographic fields displayed when entering patient demographics.

NOTE: The following fields affect waveform analysis: Age, Gender, Race, Medication, and Class.

Demographic field options:

- **OFF**—disables a field. The field does not display when entering patient demographics.
- **ON** or **ON, CLEAR**—enables a field and clears previously entered information. The field displays when entering patient demographics.
- **ON, HOLD**—enables a field and retains previously entered information. The previously entered information is saved until the field is re-entered.

| Patient Menu Items | Description | Selections |
|---|---|---|
| Last Name First Name Date of Birth Age Age Format Gender Race Medication 1 Medication 2 Class 1 Class 2 Height Weight Systolic BP Diastolic BP | Select the patient information fields to display in the Enter New Patient menu. | ON OFF |
| Department Room Technician Physician User Field | Select the local fields to display in the Enter New Patient menu. | ON, CLEAR ON, HOLD OFF |
| User Field Label | Displays if User Field is ON, CLEAR or ON, HOLD . Backspace to clear the field and then enter up to 15 alphanumeric characters. The User Field Label renames the User Field. The new name is displayed when entering patient demographics and is printed on patient demographics reports. The User Field may be used for anything. For example, use the field for the referring physician's name. | [text entry] |
| V3 Placement | Pediatric recording of V4R only. | ON, CLEAR ON, HOLD OFF |
| Comments | Enter comments regarding the patient. | ON OFF |

Directory Settings

The patient directory is always sorted by date, with the most recent saved records at the top. The field displayed for each patient may be selected as:

- **View by ID**
- **View by Name**
- **View by Room**

System Settings

Use the **System** menu to set display preferences, password protections and battery life settings.

| System Menu Items | Description | Selections |
|--------------------------------|---|---|
| User 1-2 Select | Selects either User 1 or User 2. After a new user is selected, the Atria must restart for the settings to take effect. System settings apply to both User 1 and User 2. For more information on configuring users, see "Multiple Users" on pg. 4-1. | 1 2 |
| Date Format | Select the format for current date and date of birth. | MM/DD/YYYY DD.MM.YYYY YYYY.MM.DD |
| Date | Enter the current date. | [text entry] |
| Time | Enter the current time using a 24-hour format. NOTE: The time setting must be updated during a time change (e.g., Daylight Saving Time). If the communications option is installed and configured, then update the time zone GMT, too. For more information, see the note about UTC/GMT Time Zone Offset on page 5-4. | [text entry] |
| Height Units | Select the units to use for patient height. • IN. —Inches • CM. —Centimeters | IN. CM. |
| Weight Units | Select the units to use for patient weight. • LB. —Pounds • KG. —Kilograms | LB. KG. |
| Inst. Name | Enter the medical facility name (up to 30 characters). The information displays at the bottom of each printout. | [text entry] |
| Paper Type | Select the type of paper to automatically set the correct printing contrast. | Assurance HeartLine |
| Paper Size | Select the size of the paper. | A (8.5 x 11) A4 |
| Administrative Password | Set an administrative password to restrict Setup menu settings. (When set to ON the system prompts for a password, enter password up to 15 characters). | ON OFF |

| System Menu Items | Description | Selections |
|--|--|--|
| Directory Password | Set a directory password to restrict all directory options except Enter New Patient (see “Working with Patient Records” on pg. 8-1 for a list of directory options). (When set to ON the system prompts for a password, enter password up to 15 characters). | ON OFF |
| AC Mains Frequency | Labels ECG records with the AC line frequency and selects the appropriate line filter. See “Line Filter” on pg. 4-8. Ensure the frequency selected is correct for your region. | 50 Hz 60 Hz |
| Battery Saver Mode | When the battery saver mode is ON, the Atria automatically powers down after the interval set in the Battery Saver Timeout field. NOTE: The battery saver mode is disabled when the Atria is connected to a patient. | ON OFF |
| Battery Saver Timeout | Sets the number of seconds before the Battery Saver Mode starts. (Maximum setting 999 seconds.) | [text entry] |
| Keypad Revision | Select the keypad revision. | Revision 1 Revision 2 |
| Adjust Contrast Press Shift-Previous/Next | Press [Shift] + [Previous] or [Shift] + [Next] to adjust screen contrast anytime after power up. To continue press [Select] . | -- |
| Waveform Grid (Atria 6100 only) | Displays or hides the waveform grid. | ON OFF |

**WARNING**

Misdiagnosis. Electromagnetic interference may cause trace noise or input overload conditions. This may be caused by the presence of strong EMI fields, or generated by RF noise on the line power, or by electronic, surgical, or diathermy instruments in close proximity to the Atria. Position the Atria away from other electrical or electronic equipment, if possible.

If used with, or around, other electrical or electronic equipment, always carefully monitor initial readings to verify normal operation.

The Atria is compliant with IEC 60601-1-2 EMC immunity requirements. Refer to “EMC Declaration Tables” on pg. 11-10.

External communications are optional on the Atria.

For assistance in determining which options are available on your Atria, or to purchase additional options, call Customer Service at (800) 777-1777 or (608) 764-1919.

Base communications options include:

- Serial Communications (RS232)
- Wired Ethernet
- USB
- Analog Out

The following features require the Communications options:

- Email
- Fax
- Plain paper printing
- EMR communications

Additional communication options include:

- Internal Fax/Modem
- BlueTooth connection
- 802.11 network connection
- PPP connection

NOTE: Wireless options transmit at 2.4 GHz. Other nearby wireless devices may cause interference. If possible, move or turn off other devices to minimize potential interference.

Setting up any of the communications options listed above may require assistance from the Network Administrator or IT department.

Equipment Connections

WARNING



Trip hazard. Route all cables away from main work areas to minimize risk of tripping and injury.

Figure 5-1
Back Panel

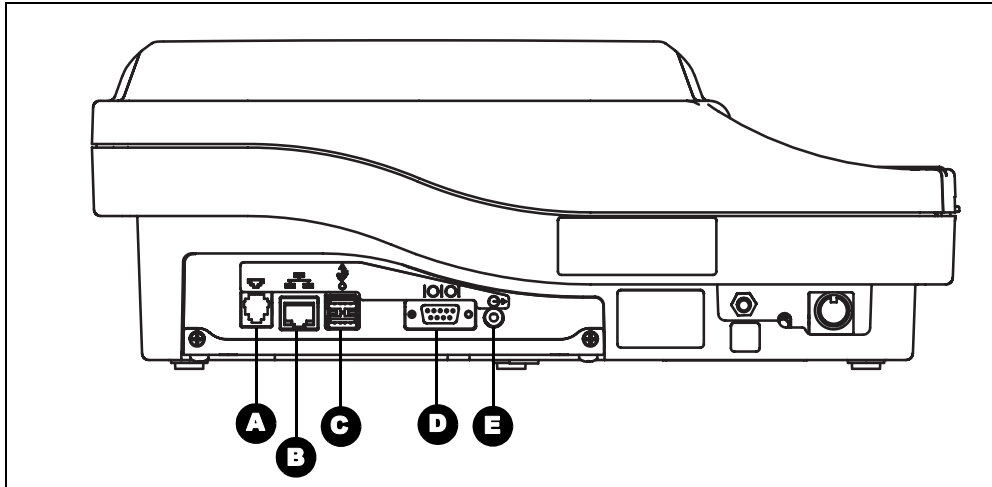

Key



| | | |
|----------|-----------------------------|--|
| A | Modem | RJ11 port to connect telephone cable. |
| B | Network | RJ45 port to connect network cable. NOTE: Do not insert the telephone cable in the Network port. |
| C | USB host¹ | USB type A port to connect USB printer or USB wireless adapter. |
| D | Serial | RS-232 a 9pin serial port to connect external fax/modem or direct connection to management system. |
| E | Analog output | Analog port to connect a monitor or other device. (Contact Technical Support for approved cables). |

¹The Atria conforms to the all safety and essential performance standards. Every effort has been made to ensure the Atria will be safe when used with systems containing other equipment. When Atria is connected to another device using a USB cable, it is important to ensure the cable will not create excessive radio frequency emissions. To minimize this risk, a ferrite cable emissions reducer (p/n 040-1508-00) is available as an Atria accessory (see the Accessories List for ordering instructions) and must be used with any USB cable connected to the Atria. Follow the installation instructions supplied with the ferrite cable emission reducer.

Grounding

All connected equipment must be IEC 60950 approved or equivalent. Consult a qualified technician to verify equipment compatibility.

Network Setup

The following communication options require network setup:

- Email
- Printing to network printers
- Sending to EMR via network connection
- Sending to shared location on network

NOTE: Press **[ALT] + [H]** to access the **Help** menu. Select **Network Setup** for additional information.

Atria Network Configuration

The facility network must be set up before connecting the Atria to the network. Use these instructions to configure Ethernet and 802.11 networks.

1. Press **[Home]** and then press **[Setup]**.
2. Select **Send Receive > Setup Network Connection**.

ETHERNET CONNECTION SETUP

To set up the network using an RJ-45 Ethernet connection

1. Select **Network Type > Ethernet > Use DHCP**:
 - (Recommended) Select **ON** for dynamic IP address assignment.
 - Select **OFF** for fixed IP address assignment.
2. Enter the following:
 - a. When DHCP is **OFF** enter:
 - **IP address** (IP Address for the Atria, typically assigned by the network administrator.)
 - **Subnet Mask** (typically 255.255.255.0).
 - **Gateway** (IP address for the Gateway.)

b. **UTC/GMT Time Zone Offset**

- The default is 6 for Central Standard Time
- For other time zones, use the Time Zone listed on your computer.

NOTE: The Windows UTC/GMT Time Zone Offsets are the inverse of the Atria. For example, Windows Central Standard Time is -6, but the Atria notates Central Standard Time as 6. (The opposite is also true: Perth, Australia is +8 in Windows and is -8 for the Atria.)

Decrease the time zone value by one hour on the Atria during Daylight Saving Time (or Summer Time period). Refer to “Time” on pg. 4-13 to change the current time setting.

During this period, the displayed current time in Atria and the network will match, but the time zone values will be different.

802.11 AND ETHERNET/802.11 CONNECTION SETUP

The Atria uses an 802.11g USB adapter for either a 802.11b or 802.11g networks. The Atria automatically scans all channels to find the correct channel used by the access point at a given location.

Use the **Ethernet/802.11** selection to set up both an Ethernet and a 802.11 connection. The system will send the data over a wireless network if a connection is available. If a wireless connection is not available, connect a network cable to send the record.

1. Select **Network Type > 802.11 > Use DHCP** or **Network Type > Ethernet/802.11 > Use DHCP**.
 - (Recommended) Select **ON** for dynamic IP address assignment.
 - Select **OFF** for fixed IP address assignment.
2. Select a setting for **Wireless Security**:
 - **None** (Turn off Wireless security)
 - **WEP** (Wired Equivalent Privacy)

When Wireless Security is WEP: Select the setting for **Wireless Authentication**:

- **open**
- **shared**
- **WPA or WPA2 Personal** (Wi-Fi Protected Access)
- **Supplicant Config** (custom configuration)
- **WPA or WPA2 Enterprise** (Wi-Fi Protected Access)

3. Enter the following:
 - a. When DHCP is **OFF** enter:
 - **IP address** (IP Address for the Atria, typically assigned by the network administrator.)
 - **Subnet Mask** (typically 255.255.255.0).
 - **Gateway** (IP address for the Gateway.)
 - b. Select appropriate options based on the Wireless Security settings. Refer to the table below.

| Wireless Security Setting | Setting Options |
|--|--|
| None | Wireless SSID¹ Wireless Channel² UTC/GMT Time Zone Offset⁴ |
| WEP | Wireless Authentication Wireless SSID¹ Wireless Channel² Encryption key 1 Encryption key 2 Encryption key 3 Encryption key 4 UTC/GMT Time Zone Offset⁴ |
| WPA or WPA2 Personal | Wireless SSID¹ WPA/WPA2 Passphrase³ UTC/GMT Time Zone Offset⁴ |
| Supplicant Config For more information on configuring and alternative security option see "Security Settings: Supplicant Configuration" on pg. 5-6. | UTC/GMT Time Zone Offset⁴ |
| WPA or WPA2 Enterprise | Wireless SSID¹ WPA/WPA2 Enterprise ID WPA/WPA2 Enterprise Password³ UTC/GMT Time Zone Offset⁴ |
| ¹ The Wireless SSID , and the WPA/WPA2 Passphrase is either SSID or DSSID as configured on the wireless access point. ² The Wireless Channel is configured on the wireless access point. ³ The WPA/WPA2 Enterprise ID , and the WPA/WPA2 Enterprise Password is configured on the RADIUS Authentication server. ⁴ See the Time Zone instructions and note on 5-4 for configuring the UTC/GMT Time Zone Offset . | |

PPP SETUP

Use the PPP setting to connect the Atria to a PPP Server.

1. Select **Network Type > Ethernet > Use DHCP**:
 - (Recommended) Select **ON** for dynamic IP address assignment.
 - Select **OFF** for fixed IP address assignment.
2. Enter the following:
 - a. When DHCP is **OFF** enter:
 - **IP address** (IP Address for the Atria, typically assigned by the network administrator.)
 - **Subnet Mask** (typically 255.255.255.0)
 - **Gateway** (IP address for the Gateway)
 - b. **PPP Phone Number** (phone number of the PPP Server)
 - c. **PPP Phone Type** (select **TOUCH TONE** or **Pulse**)
 - d. **PPP User** (user name set up on the PPP server)
 - e. **PPP Password** (the password set up for the PPP user)
 - f. **UTC/GMT Time Zone Offset**
 - The default is 6 for Central Standard Time
 - For other time zones, use the Time Zone listed on your computer.
 - See the Time Zone instructions and note on 5-4 for configuring the **UTC/GMT Time Zone Offset**.

Security Settings: Supplicant Configuration

Use the Supplicant Configuration setting to configure the Atria with a custom configuration when the standard security options are not compatible with your wireless network. Use the Supplicant Configuration option if your wireless network requires the use of digital certificates.

To configure a supplicant configuration complete the following steps:

- Create a supplicant configuration file.
- Install the configuration file on the Atria.
- Install the digital certificate on the Atria.
- Configure the Atria to use the supplicant configuration.

CREATE A SUPPLICANT CONFIGURATION FILE

- On a PC, use a text editor to create a configuration file.
 - a. Follow the examples in the “Wireless Network Custom Configuration Examples” in the Atria help page or the WPA_suppllicant Reference Manual on the CD.
 - b. Specify the name and location of the digital certificate.
 - c. Save the file with the name: **config**

NOTE: Do not use a file extension for the configuration file.

- d. Copy the configuration file to a blank USB device.

INSTALL THE SUPPLICANT CONFIGURATION FILE

1. Insert the USB device containing the supplicant configuration file into the USB port on the back of the Atria.
2. Press **[Home]** and then press **[Setup]**.
3. Select **Service Functions** from the **Setup** menu.
4. The Atria displays a warning message, press **[Enter]**.
5. Use the navigation keys to select **Copy wpa supplicant cfg from usb** and then press **[Enter]**.

The system copies the file and displays a message indicating the transfer was successful.

6. Press **[On/Stby]** twice to reboot the Atria.

INSTALL THE DIGITAL CERTIFICATE ON THE ATRIA

1. Export the required certificate to a file on a PC. Use the pem format.
2. Copy the certificate file to a blank USB device.
3. Insert the USB device containing the certificate file into the USB port on the back of the Atria.
4. Press **[Home]** and then press **[Setup]**.
5. Select **Service Functions** from the **Setup** menu.

The Atria displays a warning message.

6. Press **[Enter]**.
7. Use the navigation keys to select **Copy wpa supplicant cert from usb** and then press **[Enter]**.

The system copies the file and displays a message indicating the transfer was successful.

8. Press **[On/Stby]** twice to reboot the Atria.

CONFIGURE THE ATRIA TO USE THE SUPPLICANT CONFIGURATION

1. Press **[Home]** and then press **[Setup]**.
2. Select **Send Receive > Setup Network Connection** from the **Setup** menu.
3. Select the following options:
 - a. **Network Type** select **802.11**.
 - b. **Use DHCP** select **ON** or **OFF**.
 - c. **Wireless Security** select **Supplicant Config**.
4. To complete the setup, configure Email, see “Setup Email” on pg. 5-10 and EMR Communications “Setup EMR Communications” on pg. 5-12.

External Printer Setup



WARNING

Shock hazard. Plain paper printers must be compliant with IEC 60950.

External printing requires network setup. See “Network Setup” on pg. 5-3.

Atria Printer Configuration

Plain paper printing is available for all printing except Manual and Auto Rhythm printouts.

1. Press **[Home]** and then press **[Setup]**.
2. Select **Printer > Plain Paper Printing** and either:
 - **Local** (USB or BlueTooth).
 - **Network** (Ethernet or 802.11)
 - **Off** (No printing)
3. Select the **Default Printer**:
 - **Thermal** (Atria)
 - **Plain Paper** (external printer).

FOR LOCAL PRINTERS ONLY:

4. Select **Printer Type**:
 - **PCL3 (DeskJet)**
 - **Postscript**
 - **PCL5 (LaserJet)**
5. Select **Find Local Printers**:
 - **Do Not Find Local Printers**

- **Start Find Local Printers**—This starts the process to find local printers.
 - The Atria automatically selects the printer. If the Atria finds more than one printer, use the navigation buttons to select the printer, and then press **[Select]**.

FOR NETWORKED PRINTERS ONLY:

6. Enter the **Printer IP address**
7. Select **Printer Type**:
 - **PCL3 (DeskJet)**
 - **Postscript**
 - **PCL5 (LaserJet)**

Printer Connection

1. Setup the printer per manufacturer's instructions.
2. Connect printer to Atria. Refer to "Equipment Connections" on pg. 5-2.
 - Ethernet network—Connect network cable to RJ45 port (printer must also be connected to network).
 - Wireless network—Connect the 802.11 USB adapter.
 - USB printer—Connect to USB port.
 - BlueTooth printer—Connect BlueTooth adapter to USB port.
 - PPP network—For an internal modem: Connect the phone cable. For an external modem: Connect the modem and phone cable.

Verify Printer Operation

NOTE: In order to perform this procedure: the patient cable must be plugged in and **Setup > ECG > Sequence > Auto Print** is set to **ON** and **Setup > ECG > Sequence > Auto Save** is set to **ON**.

- Press **[Home]** then press **[ECG]** twice.
 - The Atria automatically prints the ECG on the default printer. To configure the default printer select **Setup > Printer > Default Printer**.

Setup Fax



WARNING

Misdiagnosis. Records sent by fax may not be suitable for diagnostic use due to the low resolution of some fax receiving equipment.

Enter up to four 20-digit fax numbers (include outside line access number, if necessary).

1. Connect telephone line to the RJ11 port.

NOTE: See “Equipment Connections” on pg. 5-2 for Atria connection diagrams. The modem will not work if phone cord is connected to the network port).

2. Press **[Home]** and then press **[Setup]**.
3. Select **Send Receive > Setup Fax > Enabled** and then select either **TOUCH TONE** or **Pulse**.
4. For each fax, enter a fax number and description.
5. Verify fax operation:
 - a. Press **[Home]** then press **[ECG]** twice.
 - b. Select **Fax ECG**.
 - c. Select the fax destination and verify the receiving fax machine successfully prints out the ECG.

Setup Email



WARNING

Misdiagnosis. ECG reports images viewed or printed in .pdf format at a size other than 100% may be appear distorted.

Network setup is required in order to use the email option. See “Network Setup” on pg. 5-3.

Refer to “Equipment Connections” on pg. 5-2.

- For Ethernet network, connect to network via RJ45 port.
- For 802.11, connect to the 802.11 USB port.

The Atria emails ECG reports in .pdf format.

1. Press **[Home]** and then press **[Setup]**.

-
-
2. Select **Send Receive > Email > Enabled** and complete the following entries:
 - a. **SMTP Server Address** enter in the format: nnn.nnn.nnn.nnn.
 - b. **Email Comment** enter **ON** to add an optional single line to the body of the email.
 - c. **Sender Address** enter the “from” address.
 - d. **Email ‘Reply to’** (Atria 3100) or **Reply to Address** (Atria 6100) to enter the address for replies.
 - e. For each email address, enter the **Email Destination Label** and descriptions.

NOTE: **Email Address #1** is the default address. See “Auto Email” on pg. 4-5.

3. Verify email operation:
 - a. Press **[Home]** then press **[ECG]** twice.
 - b. Select **Email ECG** and then select the email destination.
 - c. Verify the ECG email was successfully received.

Setup EMR Communications

Network setup is required in order to send records to an EMR system or a shared location on the network. See “Network Setup” on pg. 5-3 and “Equipment Connections” on pg. 5-2.

Set up Web Services

Follow the instructions below to configure communication with an EMR system such as Heartcentrix® or the Pyramis® ECG Database Management system (version 6.1 or later).

When the Atria is configured to communicate to an EMR system:

- The Atria can send ECG records to the EMR system.
- The Atria can retrieve previous ECG records from the EMR system.
- If the EMR system supports order-entry the Atria can retrieve orders from the EMR system.

For more information see “Sending ECG Records to an EMR System” on pg. 8-7 and “Retrieving ECG Records and Orders from an EMR System with Web Services” on pg. 8-9.

NOTE: To connect to the web via a network, configure this device for the network. Refer to the appropriate section in Network Setup for wired ethernet, 802.11, wireless, or PPP network setup.

CONFIGURE WEB SERVICE

1. Press **[Home]** and then press **[Setup]**.
2. Select **Send Receive > Setup EMR Connection**.
3. Select **EMR Connection > Web Services**
4. Select **EMR Description** and enter the name of the server, or a text description of the EMR the Atria will connect to.
5. Select **Web Services URL/IP** and enter the URL components as follows:
 - a. For a secure server, enter **https://** otherwise, enter **http://**.
 - b. Enter the IP address of the server followed by a slash (/).
 - c. Enter the pathname followed by a slash (/).
 - d. Enter the server application name.

For example: **https://198.24.137.22/heartcentrixapi/userwebapi.asmx**.

6. Enter the **Web Services Provider ID**.

For more information, see your EMR administrator.

7. Enter the **Institution Number**.

The Institution number is transmitted to the EMR system with the ECG record. Enter **1**, unless the server services multiple institutions.

8. Enter a **Device ID**.

The Device ID is transmitted to the EMR system with the ECG record. Enter a unique number to identify this specific ECG device.

REGISTER THE ATRIA WITH THE WEB SERVER

1. Press **[Home]** and then press **[Setup]**.
2. Select **Send Receive > Register Device with Web Services**.
3. Enter the **Web Services Provider ID**.

For more information, see your EMR administrator.

4. Enter the **Web User ID**.
5. Enter the **Web Password**.
6. Verify the Atria is connected to the network with either a 802.11 or an ethernet cable.
7. Press **[Send/Rec]**.

After a few seconds the Atria displays a list of one or more institutions.

8. Select the institution that matches the **Institution ID** entered in step 7., “Configure Web Service” on pg. 5-12.
9. Press **[Send/Rec]** to send the registration.

NOTE: If the Atria reports errors, the communications log contains more information regarding the errors. To print the communications log: Press **[Setup]** and then select **Print Communications Log**. For more information, press **[ALT] + [H]** to access the **Help** menu and select **Troubleshooting > Communications**.

DOWNLOAD THE EMR-SUPPLIED CUSTOM HEADER

NOTE: The Atria must be registered before performing this procedure, see “Register the Atria with the Web Server” on pg. 5-13

1. Press **[Home]** and then press **[Send/Rec]**.
2. Select **Get Custom Header**.

After a few seconds the Atria displays a list of one or more custom headers.

3. Select the appropriate custom header.

The Atria prompts to restart.

NOTE: If the Atria reports errors, the communications log contains more information regarding the errors. To print the communications log: Press **[Setup]** and then select **Print Communications Log**. For more information, press **[ALT] + [H]** to access the **Help** menu and select **Troubleshooting > Communications**.

4. Press any key.

The Atria restarts with the new custom header. The Atria is ready to communicate with the EMR System.

**WARNING**

Explosion hazard. Do not use in the presence of flammable anesthetics, other gasses that support combustion, or in a high-oxygen atmosphere.

**WARNING**

Misdiagnosis. Electromagnetic interference may cause trace noise or input overload conditions. This may be caused by the presence of strong EMI fields, or generated by RF noise on the line power, or by electronic, surgical, or diathermy instruments in close proximity to the Atria. Position the Atria and the patient cable away from other electrical or electronic equipment, if possible.

If used with, or around, other electrical or electronic equipment, always carefully monitor initial readings to verify normal operation.

The Atria is compliant with IEC 60601-1-2 EMC immunity requirements. Refer to “EMC Declaration Tables” on pg. 11-10.

**WARNING**

Misdiagnosis. Using unshielded or excessively long cables may cause or increase susceptibility to electromagnetic interference.

Always use the shortest possible shielded cables.

Overview

Patient preparation consists of the following steps:

1. Patient preparation. See “Patient Preparation” on pg. 6-2.
2. Skin preparation. See “Skin Preparation” on pg. 6-2.
3. Apply sensors.
 - For placement information, see “Resting ECG Lead Placement & Coding Chart” on pg. 6-4 or “Alternative Lead Placements” on pg. 6-8.
 - For sensor-specific instructions, see “Disposable Resting ECG Sensors” on pg. 6-5 or “Reusable ECG Sensors” on pg. 6-6.
4. Apply sensors and connect the patient cable and lead wires before entering patient information this allows the sensors to adhere, stabilize, and improve conductivity. See “Connecting Cables and Lead Wires” on pg. 6-8.

Patient Preparation

The following steps are necessary for patient comfort and to minimize muscle artifacts:

- Assure the patient there is no danger or discomfort involved.
- Explain that full cooperation will produce a valuable diagnostic record.
- Ensure the patient is comfortable and relaxed.
 - Lay the patient on a cot or padded table large enough to support both arms and legs.
 - Arms should rest at the side and the legs should lie flat and not touching.
 - Support the head with a pillow.
 - Avoid cold drafts and cover the patient with a blanket to prevent shivering (leave the chest and sensor sites exposed).

Skin Preparation

Refer to the “Resting ECG Lead Placement & Coding Chart” on pg. 6-4 for details on where sensor sites are located.

For information on alternate chest lead and other lead placements, see “Alternative Lead Placements” on pg. 6-8.

1. Use the thumb and forefinger to part hair when necessary. Clipping or shaving may be required.
2. If skin has lotion on it or the patient is diaphoretic, clean skin with alcohol and abrade slightly with a dry gauze.
3. Ensure the skin is completely dry.

Sensor Application

WARNING



False Readings. The lead status check does not detect lead reversals.

Always ensure the correct lead placement is used for the lead configuration selected.

WARNING



Misdiagnosis. Dirty, compromised, or unprepared skin may cause incorrect readings.

Before applying sensors, ensure the skin is clean, unbroken, and properly prepared.

WARNING



Infection. Lead placement on compromised skin may cause infection.

Before applying sensors, ensure the skin is clean, unbroken, and properly prepared.

Caution



Patient skin irritation. When applying sensors, skin preparation, electrolyte solution, or electrode material may cause skin irritation. **Monitor the electrode site and, if irritation occurs, use alternative electrolyte or electrodes.**

Apply sensors according to the instructions on the following pages (for additional lead placement options, see “Alternative Lead Placements” on pg. 6-8).

For information on using disposable sensors, see “Disposable Resting ECG Sensors” on pg. 6-5. For information on using reusable sensors, see “Reusable ECG Sensors” on pg. 6-6.

NOTE: Apply sensors and connect the patient cable and lead wires before entering patient information this allows the sensors to adhere, stabilize, and improve conductivity.

Resting ECG Lead Placement & Coding Chart

| | LEAD CODING AND MEASUREMENTS | | | | | | | | | | | | | | | | | | | | | | | | | | | | | | | | | | | | | | | | | | | | | | | | | | | | | | | | | | | | | | |
|--|-------------------------------------|------------------------------|--|-------------------------------|----------------|-------------------------------|----------------|-------------------------------|----------------|---|----------------|-------------------------------|----------------|-------------------------------|----|-----------|--|------|------------------------------|----------------|----------------------------|----------------|----------------------------|----------------|----------------------------|----------------|----------------------------|----------------|----------------------------|----------------|----------------------------|-------|-------|-----|----------------|-------|-------|--------|----------------|-------|-------|-------|----------------|-------|-------|-------|----------------|-------|-------|--------|----------------|-------|-------|--------|---|------|------------------------------|--------|-------------|---------|-------------|----------|-------------|
| AHA STANDARD LIMB LEADS | | AHA COLOR CODE | IEC STANDARD LIMB LEADS | | | | | | | | | | | | | | | | | | | | | | | | | | | | | | | | | | | | | | | | | | | | | | | | | | | | | | | | | | | | |
| <table border="1" style="width: 100%; border-collapse: collapse;"> <thead> <tr> <th>LEAD</th> <th>SENSORS CONNECTED / MEASURED</th> </tr> </thead> <tbody> <tr> <td>LEAD I</td> <td>LA-RA</td> </tr> <tr> <td>LEAD II</td> <td>LL-RA</td> </tr> <tr> <td>LEAD III</td> <td>LL-LA</td> </tr> </tbody> </table> | LEAD | SENSORS CONNECTED / MEASURED | LEAD I | LA-RA | LEAD II | LL-RA | LEAD III | LL-LA | | <table border="1" style="width: 100%; border-collapse: collapse;"> <thead> <tr> <th>LEAD</th> <th>LOCATION</th> <th>BAND</th> <th>LABEL</th> </tr> </thead> <tbody> <tr> <td>RL</td> <td>RIGHT LEG</td> <td>GREEN</td> <td></td> </tr> <tr> <td>LL</td> <td>LEFT LEG</td> <td>RED</td> <td></td> </tr> <tr> <td>RA</td> <td>RIGHT ARM</td> <td>WHITE</td> <td></td> </tr> <tr> <td>LA</td> <td>LEFT ARM</td> <td>BLACK</td> <td></td> </tr> <tr> <td>V₁</td> <td>CHEST</td> <td>BROWN</td> <td>RED</td> </tr> <tr> <td>V₂</td> <td>CHEST</td> <td>BROWN</td> <td>YELLOW</td> </tr> <tr> <td>V₃</td> <td>CHEST</td> <td>BROWN</td> <td>GREEN</td> </tr> <tr> <td>V₄</td> <td>CHEST</td> <td>BROWN</td> <td>BLUE</td> </tr> <tr> <td>V₅</td> <td>CHEST</td> <td>BROWN</td> <td>ORANGE</td> </tr> <tr> <td>V₆</td> <td>CHEST</td> <td>BROWN</td> <td>VIOLET</td> </tr> </tbody> </table> | LEAD | LOCATION | BAND | LABEL | RL | RIGHT LEG | GREEN | | LL | LEFT LEG | RED | | RA | RIGHT ARM | WHITE | | LA | LEFT ARM | BLACK | | V ₁ | CHEST | BROWN | RED | V ₂ | CHEST | BROWN | YELLOW | V ₃ | CHEST | BROWN | GREEN | V ₄ | CHEST | BROWN | BLUE | V ₅ | CHEST | BROWN | ORANGE | V ₆ | CHEST | BROWN | VIOLET | <table border="1" style="width: 100%; border-collapse: collapse;"> <thead> <tr> <th>LEAD</th> <th>SENSORS CONNECTED / MEASURED</th> </tr> </thead> <tbody> <tr> <td>LEAD I</td> <td>L-R</td> </tr> <tr> <td>LEAD II</td> <td>F-R</td> </tr> <tr> <td>LEAD III</td> <td>F-L</td> </tr> </tbody> </table> | LEAD | SENSORS CONNECTED / MEASURED | LEAD I | L-R | LEAD II | F-R | LEAD III | F-L |
| LEAD | SENSORS CONNECTED / MEASURED | | | | | | | | | | | | | | | | | | | | | | | | | | | | | | | | | | | | | | | | | | | | | | | | | | | | | | | | | | | | | | |
| LEAD I | LA-RA | | | | | | | | | | | | | | | | | | | | | | | | | | | | | | | | | | | | | | | | | | | | | | | | | | | | | | | | | | | | | | |
| LEAD II | LL-RA | | | | | | | | | | | | | | | | | | | | | | | | | | | | | | | | | | | | | | | | | | | | | | | | | | | | | | | | | | | | | | |
| LEAD III | LL-LA | | | | | | | | | | | | | | | | | | | | | | | | | | | | | | | | | | | | | | | | | | | | | | | | | | | | | | | | | | | | | | |
| LEAD | LOCATION | BAND | LABEL | | | | | | | | | | | | | | | | | | | | | | | | | | | | | | | | | | | | | | | | | | | | | | | | | | | | | | | | | | | | |
| RL | RIGHT LEG | GREEN | | | | | | | | | | | | | | | | | | | | | | | | | | | | | | | | | | | | | | | | | | | | | | | | | | | | | | | | | | | | | |
| LL | LEFT LEG | RED | | | | | | | | | | | | | | | | | | | | | | | | | | | | | | | | | | | | | | | | | | | | | | | | | | | | | | | | | | | | | |
| RA | RIGHT ARM | WHITE | | | | | | | | | | | | | | | | | | | | | | | | | | | | | | | | | | | | | | | | | | | | | | | | | | | | | | | | | | | | | |
| LA | LEFT ARM | BLACK | | | | | | | | | | | | | | | | | | | | | | | | | | | | | | | | | | | | | | | | | | | | | | | | | | | | | | | | | | | | | |
| V ₁ | CHEST | BROWN | RED | | | | | | | | | | | | | | | | | | | | | | | | | | | | | | | | | | | | | | | | | | | | | | | | | | | | | | | | | | | | |
| V ₂ | CHEST | BROWN | YELLOW | | | | | | | | | | | | | | | | | | | | | | | | | | | | | | | | | | | | | | | | | | | | | | | | | | | | | | | | | | | | |
| V ₃ | CHEST | BROWN | GREEN | | | | | | | | | | | | | | | | | | | | | | | | | | | | | | | | | | | | | | | | | | | | | | | | | | | | | | | | | | | | |
| V ₄ | CHEST | BROWN | BLUE | | | | | | | | | | | | | | | | | | | | | | | | | | | | | | | | | | | | | | | | | | | | | | | | | | | | | | | | | | | | |
| V ₅ | CHEST | BROWN | ORANGE | | | | | | | | | | | | | | | | | | | | | | | | | | | | | | | | | | | | | | | | | | | | | | | | | | | | | | | | | | | | |
| V ₆ | CHEST | BROWN | VIOLET | | | | | | | | | | | | | | | | | | | | | | | | | | | | | | | | | | | | | | | | | | | | | | | | | | | | | | | | | | | | |
| LEAD | SENSORS CONNECTED / MEASURED | | | | | | | | | | | | | | | | | | | | | | | | | | | | | | | | | | | | | | | | | | | | | | | | | | | | | | | | | | | | | | |
| LEAD I | L-R | | | | | | | | | | | | | | | | | | | | | | | | | | | | | | | | | | | | | | | | | | | | | | | | | | | | | | | | | | | | | | |
| LEAD II | F-R | | | | | | | | | | | | | | | | | | | | | | | | | | | | | | | | | | | | | | | | | | | | | | | | | | | | | | | | | | | | | | |
| LEAD III | F-L | | | | | | | | | | | | | | | | | | | | | | | | | | | | | | | | | | | | | | | | | | | | | | | | | | | | | | | | | | | | | | |
| AUGMENTED LIMB LEADS | | IEC COLOR CODE | AUGMENTED LIMB LEADS | | | | | | | | | | | | | | | | | | | | | | | | | | | | | | | | | | | | | | | | | | | | | | | | | | | | | | | | | | | | |
| <table border="1" style="width: 100%; border-collapse: collapse;"> <thead> <tr> <th>LEAD</th> <th>SENSORS CONNECTED / MEASURED</th> </tr> </thead> <tbody> <tr> <td>aVR</td> <td>RA and (LA-LL)</td> </tr> <tr> <td>aVL</td> <td>LA and (RA-LL)</td> </tr> <tr> <td>aVF</td> <td>LL and (RA-LA)</td> </tr> </tbody> </table> | LEAD | SENSORS CONNECTED / MEASURED | aVR | RA and (LA-LL) | aVL | LA and (RA-LL) | aVF | LL and (RA-LA) | | <table border="1" style="width: 100%; border-collapse: collapse;"> <thead> <tr> <th>LEAD</th> <th>LOCATION</th> <th>BAND</th> <th>LABEL</th> </tr> </thead> <tbody> <tr> <td>N</td> <td>RIGHT LEG</td> <td>BLACK</td> <td></td> </tr> <tr> <td>F</td> <td>LEFT LEG</td> <td>GREEN</td> <td></td> </tr> <tr> <td>R</td> <td>RIGHT ARM</td> <td>RED</td> <td></td> </tr> <tr> <td>L</td> <td>LEFT ARM</td> <td>YELLOW</td> <td></td> </tr> <tr> <td>C₁</td> <td>CHEST</td> <td>WHITE</td> <td>RED</td> </tr> <tr> <td>C₂</td> <td>CHEST</td> <td>WHITE</td> <td>YELLOW</td> </tr> <tr> <td>C₃</td> <td>CHEST</td> <td>WHITE</td> <td>GREEN</td> </tr> <tr> <td>C₄</td> <td>CHEST</td> <td>WHITE</td> <td>BROWN</td> </tr> <tr> <td>C₅</td> <td>CHEST</td> <td>WHITE</td> <td>BLACK</td> </tr> <tr> <td>C₆</td> <td>CHEST</td> <td>WHITE</td> <td>VIOLET</td> </tr> </tbody> </table> | LEAD | LOCATION | BAND | LABEL | N | RIGHT LEG | BLACK | | F | LEFT LEG | GREEN | | R | RIGHT ARM | RED | | L | LEFT ARM | YELLOW | | C ₁ | CHEST | WHITE | RED | C ₂ | CHEST | WHITE | YELLOW | C ₃ | CHEST | WHITE | GREEN | C ₄ | CHEST | WHITE | BROWN | C ₅ | CHEST | WHITE | BLACK | C ₆ | CHEST | WHITE | VIOLET | <table border="1" style="width: 100%; border-collapse: collapse;"> <thead> <tr> <th>LEAD</th> <th>SENSORS CONNECTED / MEASURED</th> </tr> </thead> <tbody> <tr> <td>aVR</td> <td>R and (L-F)</td> </tr> <tr> <td>aVL</td> <td>L and (R-F)</td> </tr> <tr> <td>aVF</td> <td>F and (R-L)</td> </tr> </tbody> </table> | LEAD | SENSORS CONNECTED / MEASURED | aVR | R and (L-F) | aVL | L and (R-F) | aVF | F and (R-L) |
| LEAD | SENSORS CONNECTED / MEASURED | | | | | | | | | | | | | | | | | | | | | | | | | | | | | | | | | | | | | | | | | | | | | | | | | | | | | | | | | | | | | | |
| aVR | RA and (LA-LL) | | | | | | | | | | | | | | | | | | | | | | | | | | | | | | | | | | | | | | | | | | | | | | | | | | | | | | | | | | | | | | |
| aVL | LA and (RA-LL) | | | | | | | | | | | | | | | | | | | | | | | | | | | | | | | | | | | | | | | | | | | | | | | | | | | | | | | | | | | | | | |
| aVF | LL and (RA-LA) | | | | | | | | | | | | | | | | | | | | | | | | | | | | | | | | | | | | | | | | | | | | | | | | | | | | | | | | | | | | | | |
| LEAD | LOCATION | BAND | LABEL | | | | | | | | | | | | | | | | | | | | | | | | | | | | | | | | | | | | | | | | | | | | | | | | | | | | | | | | | | | | |
| N | RIGHT LEG | BLACK | | | | | | | | | | | | | | | | | | | | | | | | | | | | | | | | | | | | | | | | | | | | | | | | | | | | | | | | | | | | | |
| F | LEFT LEG | GREEN | | | | | | | | | | | | | | | | | | | | | | | | | | | | | | | | | | | | | | | | | | | | | | | | | | | | | | | | | | | | | |
| R | RIGHT ARM | RED | | | | | | | | | | | | | | | | | | | | | | | | | | | | | | | | | | | | | | | | | | | | | | | | | | | | | | | | | | | | | |
| L | LEFT ARM | YELLOW | | | | | | | | | | | | | | | | | | | | | | | | | | | | | | | | | | | | | | | | | | | | | | | | | | | | | | | | | | | | | |
| C ₁ | CHEST | WHITE | RED | | | | | | | | | | | | | | | | | | | | | | | | | | | | | | | | | | | | | | | | | | | | | | | | | | | | | | | | | | | | |
| C ₂ | CHEST | WHITE | YELLOW | | | | | | | | | | | | | | | | | | | | | | | | | | | | | | | | | | | | | | | | | | | | | | | | | | | | | | | | | | | | |
| C ₃ | CHEST | WHITE | GREEN | | | | | | | | | | | | | | | | | | | | | | | | | | | | | | | | | | | | | | | | | | | | | | | | | | | | | | | | | | | | |
| C ₄ | CHEST | WHITE | BROWN | | | | | | | | | | | | | | | | | | | | | | | | | | | | | | | | | | | | | | | | | | | | | | | | | | | | | | | | | | | | |
| C ₅ | CHEST | WHITE | BLACK | | | | | | | | | | | | | | | | | | | | | | | | | | | | | | | | | | | | | | | | | | | | | | | | | | | | | | | | | | | | |
| C ₆ | CHEST | WHITE | VIOLET | | | | | | | | | | | | | | | | | | | | | | | | | | | | | | | | | | | | | | | | | | | | | | | | | | | | | | | | | | | | |
| LEAD | SENSORS CONNECTED / MEASURED | | | | | | | | | | | | | | | | | | | | | | | | | | | | | | | | | | | | | | | | | | | | | | | | | | | | | | | | | | | | | | |
| aVR | R and (L-F) | | | | | | | | | | | | | | | | | | | | | | | | | | | | | | | | | | | | | | | | | | | | | | | | | | | | | | | | | | | | | | |
| aVL | L and (R-F) | | | | | | | | | | | | | | | | | | | | | | | | | | | | | | | | | | | | | | | | | | | | | | | | | | | | | | | | | | | | | | |
| aVF | F and (R-L) | | | | | | | | | | | | | | | | | | | | | | | | | | | | | | | | | | | | | | | | | | | | | | | | | | | | | | | | | | | | | | |
| CHEST LEADS | | | CHEST LEADS | | | | | | | | | | | | | | | | | | | | | | | | | | | | | | | | | | | | | | | | | | | | | | | | | | | | | | | | | | | | |
| <table border="1" style="width: 100%; border-collapse: collapse;"> <thead> <tr> <th>LEAD</th> <th>SENSORS CONNECTED / MEASURED</th> </tr> </thead> <tbody> <tr> <td>V₁</td> <td>V₁ and (LA-RA-LL)</td> </tr> <tr> <td>V₂</td> <td>V₂ and (LA-RA-LL)</td> </tr> <tr> <td>V₃</td> <td>V₃ and (LA-RA-LL)</td> </tr> <tr> <td>V₄</td> <td>V₄ and (LA-RA-LL)</td> </tr> <tr> <td>V₅</td> <td>V₅ and (LA-RA-LL)</td> </tr> <tr> <td>V₆</td> <td>V₆ and (LA-RA-LL)</td> </tr> </tbody> </table> | LEAD | SENSORS CONNECTED / MEASURED | V ₁ | V ₁ and (LA-RA-LL) | V ₂ | V ₂ and (LA-RA-LL) | V ₃ | V ₃ and (LA-RA-LL) | V ₄ | V ₄ and (LA-RA-LL) | V ₅ | V ₅ and (LA-RA-LL) | V ₆ | V ₆ and (LA-RA-LL) | | | <table border="1" style="width: 100%; border-collapse: collapse;"> <thead> <tr> <th>LEAD</th> <th>SENSORS CONNECTED / MEASURED</th> </tr> </thead> <tbody> <tr> <td>C₁</td> <td>C₁ and (L-R-F)</td> </tr> <tr> <td>C₂</td> <td>C₂ and (L-R-F)</td> </tr> <tr> <td>C₃</td> <td>C₃ and (L-R-F)</td> </tr> <tr> <td>C₄</td> <td>C₄ and (L-R-F)</td> </tr> <tr> <td>C₅</td> <td>C₅ and (L-R-F)</td> </tr> <tr> <td>C₆</td> <td>C₆ and (L-R-F)</td> </tr> </tbody> </table> | LEAD | SENSORS CONNECTED / MEASURED | C ₁ | C ₁ and (L-R-F) | C ₂ | C ₂ and (L-R-F) | C ₃ | C ₃ and (L-R-F) | C ₄ | C ₄ and (L-R-F) | C ₅ | C ₅ and (L-R-F) | C ₆ | C ₆ and (L-R-F) | | | | | | | | | | | | | | | | | | | | | | | | | | | | | | | | |
| LEAD | SENSORS CONNECTED / MEASURED | | | | | | | | | | | | | | | | | | | | | | | | | | | | | | | | | | | | | | | | | | | | | | | | | | | | | | | | | | | | | | |
| V ₁ | V ₁ and (LA-RA-LL) | | | | | | | | | | | | | | | | | | | | | | | | | | | | | | | | | | | | | | | | | | | | | | | | | | | | | | | | | | | | | | |
| V ₂ | V ₂ and (LA-RA-LL) | | | | | | | | | | | | | | | | | | | | | | | | | | | | | | | | | | | | | | | | | | | | | | | | | | | | | | | | | | | | | | |
| V ₃ | V ₃ and (LA-RA-LL) | | | | | | | | | | | | | | | | | | | | | | | | | | | | | | | | | | | | | | | | | | | | | | | | | | | | | | | | | | | | | | |
| V ₄ | V ₄ and (LA-RA-LL) | | | | | | | | | | | | | | | | | | | | | | | | | | | | | | | | | | | | | | | | | | | | | | | | | | | | | | | | | | | | | | |
| V ₅ | V ₅ and (LA-RA-LL) | | | | | | | | | | | | | | | | | | | | | | | | | | | | | | | | | | | | | | | | | | | | | | | | | | | | | | | | | | | | | | |
| V ₆ | V ₆ and (LA-RA-LL) | | | | | | | | | | | | | | | | | | | | | | | | | | | | | | | | | | | | | | | | | | | | | | | | | | | | | | | | | | | | | | |
| LEAD | SENSORS CONNECTED / MEASURED | | | | | | | | | | | | | | | | | | | | | | | | | | | | | | | | | | | | | | | | | | | | | | | | | | | | | | | | | | | | | | |
| C ₁ | C ₁ and (L-R-F) | | | | | | | | | | | | | | | | | | | | | | | | | | | | | | | | | | | | | | | | | | | | | | | | | | | | | | | | | | | | | | |
| C ₂ | C ₂ and (L-R-F) | | | | | | | | | | | | | | | | | | | | | | | | | | | | | | | | | | | | | | | | | | | | | | | | | | | | | | | | | | | | | | |
| C ₃ | C ₃ and (L-R-F) | | | | | | | | | | | | | | | | | | | | | | | | | | | | | | | | | | | | | | | | | | | | | | | | | | | | | | | | | | | | | | |
| C ₄ | C ₄ and (L-R-F) | | | | | | | | | | | | | | | | | | | | | | | | | | | | | | | | | | | | | | | | | | | | | | | | | | | | | | | | | | | | | | |
| C ₅ | C ₅ and (L-R-F) | | | | | | | | | | | | | | | | | | | | | | | | | | | | | | | | | | | | | | | | | | | | | | | | | | | | | | | | | | | | | | |
| C ₆ | C ₆ and (L-R-F) | | | | | | | | | | | | | | | | | | | | | | | | | | | | | | | | | | | | | | | | | | | | | | | | | | | | | | | | | | | | | | |

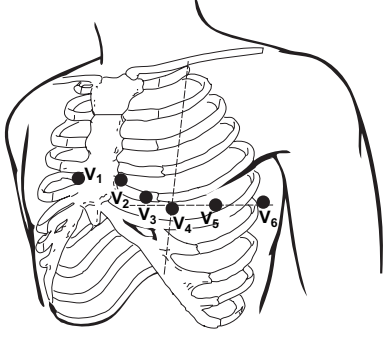
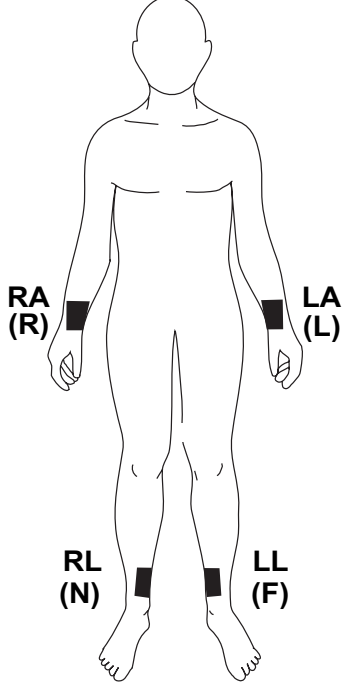
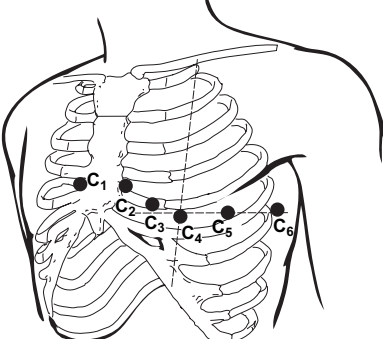
| PLACEMENT OF THE CHEST SENSORS | PLACEMENT OF THE LIMB SENSORS |
|---|--|
| AHA | |
|  |  |
| IEC | |
|  | <p>C₁ Fourth intercostal space at right margin of sternum</p> <p>C₂ Fourth intercostal space at left margin of sternum</p> <p>C₃ Midway between position C₂ and position C₄</p> <p>C₄ Fifth intercostal space at junction of left midclavicular line</p> <p>C₅ At horizontal level of position C₄ at left anterior axillary line</p> <p>C₆ At horizontal level of position C₄ at left midaxillary line</p> |

Disposable Resting ECG Sensors

CardioSens[®] disposable sensors are more effective than bulbs, plates, straps, creams, and gels. CardioSens disposable sensors reduce cross-contamination and infection and improve diagnostic results.

Disposable sensors must be stored according to the guidelines on the packaging and must not be used after the expiration date. Always store opened packages of disposable sensors in a sealed container (to avoid contamination and quick dry-out).

Orient the sensors to minimize twist stress when the clip and lead wire is attached.

Caution



Baseline drift. Never mix patient electrode types or brands. Dissimilar metals or other incompatibilities may cause considerable baseline drift and may increase trace recovery time after defibrillation.

Applying Limb Sensors

1. Expose arms and legs of the patient.
2. Place sensors firmly on the prepared limb sites. Choose fleshy areas above the inside wrists and ankles, not on the bone (see Figure 6-1). Point arm sensor leads toward the elbow. Point leg leads toward chest.
3. Clip leads to the sensors. Ensure the leads do not pass twist stress onto the electrodes.

Figure 6-1
*Disposable Limb Sensor
on Arm*

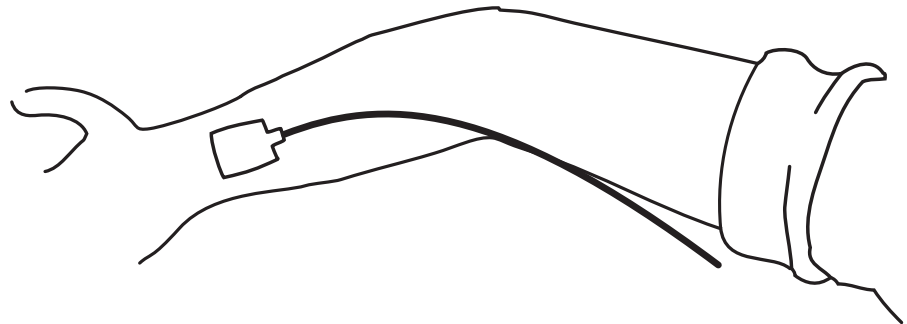

Applying Chest Sensors

1. Expose the patient's chest.
2. Locate the six V-lead or C-lead positions on the patient's chest (See "Resting ECG Lead Placement & Coding Chart" on pg. 6-4.).
3. Apply the sensors firmly on the prepared chest lead placements, ensuring the leads conform to body contours and no strain is placed on the sensors.

Reusable ECG Sensors

Caution



Baseline drift. Never mix patient electrode types or brands. Dissimilar metals or other incompatibilities may cause considerable baseline drift and may increase trace recovery time after defibrillation.

Electrolyte

NOTE: Watches or jewelry may be damaged by contact with electrolyte.

Cardiac Science Corporation recommends using Signa gel[®] electrode gel with reusable sensors because it provides excellent conductivity between the skin and sensor.

Reusable sensors (Welsh bulbs and limb plates) must be kept clean. Dirt or electrolyte build-up may degrade ECG quality:

- Wash after each use (use a mild dish soap if necessary)
- Never use a metallic pad to clean plates and Welsh bulbs (to avoid damaging the plating)
- Discard if corroded.

Applying limb plates

Caution



Patient skin irritation. Limb Plates may contain nickel, a material that can cause skin irritation. Monitor the electrode site and, if irritation occurs, use an alternate electrode.

1. Expose the arms and legs of the patient.
2. Connect sensor straps to the “ears” of the limb plates.

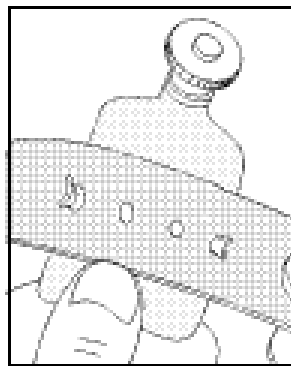

3. Squeeze out a small amount of Signa gel electrode gel on limb plate as illustrated. Spread it evenly over the limb plate surface. Apply the same amount of electrolyte to each sensor.

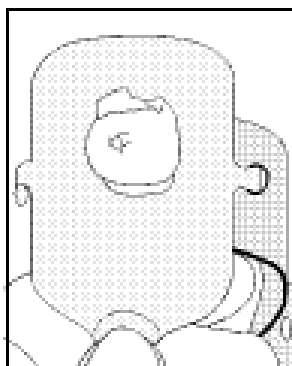

4. Place sensors firmly on the limb sites. Choose fleshy areas above wrists and ankles. Position so the limb plate will not press against the body or table when the patient is relaxed. On arms, the screws should point downward toward the feet. On legs, the screws should point upward, toward chest.
5. Without stretching the strap, wrap it around the limb until a hole lines up with a sensor “ear.” Then stretch the strap and fasten it with the next hole.
6. Connect the limb leads to the four limb plates.

Applying Welsh bulb chest sensors

Caution



Patient skin irritation. Welsh bulb sensors may contain nickel, a material that can cause skin irritation. Monitor the electrode site and, if irritation occurs, use an alternate electrode.

1. Connect the 6 Welsh bulb sensors to the V-leads (C-leads) on the patient cable.
2. Locate the 6 V-lead (C-lead) positions on the patient’s chest (see “Resting ECG Lead Placement & Coding Chart” on pg. 6-4).
3. Squeeze out a drop of Signa gel electrode gel at each sensor site. Use a tongue depressor to spread the electrolyte (ensure it does not touch the electrolyte from another site).
4. Apply the sensors by squeezing the rubber bulb and allowing suction to hold the sensor in place. Only a small dimple should remain on the bulb when it is released.
5. Ensure the leads conform to the body contours and no strain is placed on the sensors.
6. Wipe off any residual electrolyte and check again to ensure electrolyte from one site does not touch another site.

Connecting Cables and Lead Wires

After applying sensors, connect the lead wires from the patient cable to the sensors. Make sure the lead cables follow the contours of the patient's body and lie flat.

Make sure the patient cable is plugged securely into the connector on the front of the Atria (see "Patient Cable" on pg. 2-3).

Alternative Lead Placements

Pediatric Lead Placement

NOTE: Refer to "Acquiring an ECG Using Pediatric Lead Placements" on pg. 7-3 for detailed instructions on acquiring an ECG using pediatric lead placement.

When acquiring a pediatric ECG, an alternative to the standard V₃ (C₃) placement may be used. Place the sensor in the V_{4R} (C_{4R}) position. This is across the sternum from V₄ (C₄). See Figure 6-2 for location. Improper placement will result in inaccurate waveform labeling.

Select the corrected V₃ (C₃) placement in the **Edit Patient Data** display (see "Enter Patient Demographics" on pg. 7-2). If V₃ (C₃) is placed in the V_{4R} (C_{4R}) position, select **V4R** for **V3 Placement** for proper printout labeling.

Figure 6-2
Pediatric Chest Lead
Placement

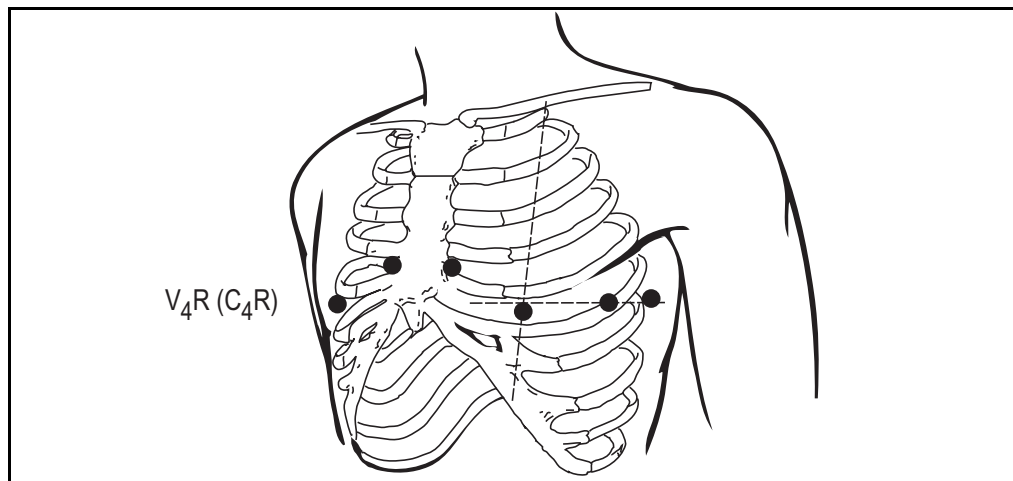

Alternate Chest Lead

NOTE: Refer to "Acquiring an ECG Using Alternative Lead Placements" on pg. 7-6 for detailed instructions on acquiring an ECG using alternate chest lead placement.

Acquire a standard 12-lead ECG according to the “Resting ECG Lead Placement & Coding Chart” on pg. 6-4.

For the Alternate Chest Lead ECG, retain the placement of the limb sensors. Reposition the chest sensors using 6 of the placements described in the table “Placement Options” on pg. 6-9. Configure leads as desired.

NOTE: The lead configuration for the Alternate Chest Lead is completely customizable. The example shown below is only one of many possible lead configurations. See “Custom Lead Settings” on pg. 4-9 for additional information.

NOTE: Lead configuration may also contain any of the standard chest leads, if desired.

| Alternate Placement | Description |
|---|---|
| V ₂ R (C ₂ R) position | fourth intercostal space at right margin of sternum |
| V ₃ R (C ₃ R) position | midway between position V ₂ R (C ₂ R) and position V ₄ R (C ₄ R) |
| V ₄ R (C ₄ R) position | fifth intercostal space at junction of right midclavicular line |
| V ₅ R (C ₅ R) position on right | horizontal level with V ₄ R (C ₄ R) at right anterior axillary line |
| V ₆ R (C ₆ R) position on right | horizontal level with V ₄ R (C ₄ R) and V ₅ R (C ₅ R) at right midaxillary line |
| V ₇ (C ₇) position | horizontal level with V ₆ (C ₆) at posterior axillary line |
| V ₈ (C ₈) position | horizontal level with V ₆ (C ₆) and V ₇ (C ₇) at mid scapular line |
| V ₉ (C ₉) position | horizontal level with V ₇ (C ₇) and V ₈ (C ₈) next to spinal column |
| V ₇ R (C ₇ R) position | horizontal level with V ₆ R (C ₆ R) at posterior axillary line |
| V ₈ R (C ₈ R) position | horizontal level with V ₆ R (C ₆ R) and V ₇ R (C ₇ R) at mid scapular line |
| V ₉ R (C ₉ R) position | horizontal level with V ₇ R (C ₇ R) and V ₈ R (C ₈ R) next to spinal column |

Figure 6-3
Placement Options

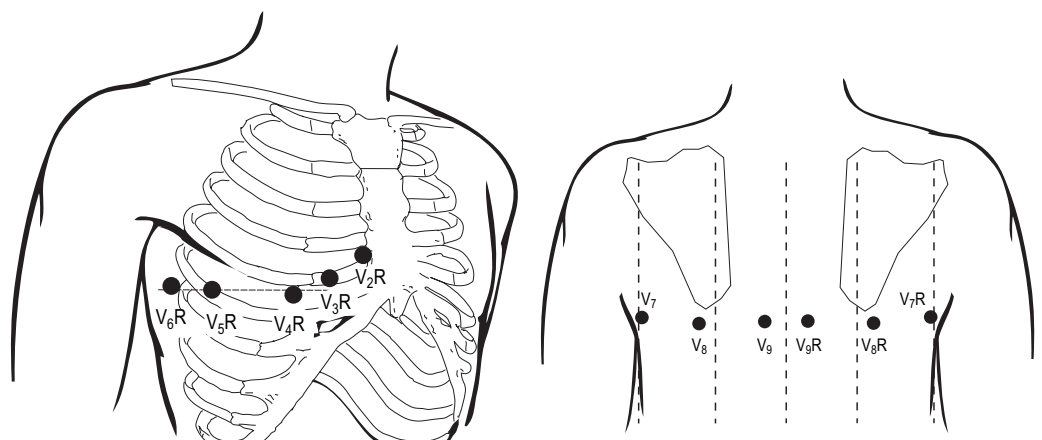

Acquiring a Stat ECG

The Atria does not require patient demographic information for an immediate ECG. Enter patient demographic information at any time. (See “ECG Tips” on pg. 7-4.)

If no patient ID is entered, the Atria prints “#STAT#, date, time” in the **Patient ID** field.

To acquire a stat ECG:

1. Prepare the patient for the recording. See “Patient Preparation” on pg. 6-1.
2. Press **[On/Stby]** if necessary.
3. Verify the patient’s heart rate displays on the **Home** screen. If the Atria does not display the heart rate, check the problem leads listed on the display. Replace faulty electrodes if necessary.
4. Press **[ECG]** twice to acquire a stat ECG report.

NOTE: Pressing **[ECG]** twice overrides the “Wait for Good Data” message and may result in a flat-line ECG because the Atria hasn’t acquired enough good data.

Recommended Workflow

If possible enter patient demographic information before performing tests. Patient demographic information also may be entered after acquisition.

WARNING



Misdiagnosis. Some patient information directly affects ECG analysis. Your patient’s physician uses this information when interpreting ECG reports. Likewise, an interpretive Atria provides more accurate and complete analysis statements when you enter complete patient information.

Prepare the Patient

Prepare the patient for the recording, see Chapter 6, “Patient Preparation”.

Enter Patient Demographics

Once patient demographics are entered, it is not necessary to immediately acquire an ECG. The Atria allows multiple patients to be entered at the same time. When acquiring an ECG for a particular patient, select the appropriate patient from the patient directory.

1. Press **[On/Stby]** if necessary.
2. Perform one of the following:
 - Press **[Patient]** select **Enter New Patient** and enter the new information as prompted.
 - Press **[Directory]** select **Enter New Patient** the new information as prompted.
 - Press **[Directory]** select **View Patient Directory** and select an existing patient. Edit the existing information as necessary

NOTE: For a complete description of the patient demographic fields, see “Patient Demographics” on pg. 7-7.

Acquire ECG

NOTE: Press **[Stop]** at any time to halt an ECG.

1. Press **[Home]**.
2. Verify the patient’s heart rate displays on the **Home** screen. If the Atria does not display the heart rate, check the problem leads listed on the display. Replace faulty electrodes if necessary.
3. Press **[ECG]**.
4. Use the navigation buttons to display **Acquire ECG, current patient data** then press **[Select]**.

NOTE: If patient demographics are in the process of being entered, the Atria prompts to use those demographics for the ECG. If not used, the demographics are not saved.

NOTE: The recorder speed, gain and frequency response settings can be temporarily modified if necessary. See “Change Recorder Speed, Gain, Frequency Response” on pg. 7-5.

Acquiring an ECG Using Pediatric Lead Placements

In order to use pediatric lead placements, the V3 placement feature must be enabled. See “V3 Placement” on pg. 4-12. To configure the Atria to always acquire ECGs using pediatric lead refer to “ECG Settings” on pg. 4-2.

1. Prepare the pediatric patient, refer to:
 - Chapter 6, “Patient Preparation.”
 - “Pediatric Chest Lead Placement” on pg. 6-8.
2. Follow steps for “Acquiring ECG Reports” on pg. 7-1.
 - For **V3 Placement**, select **V4R**.

NOTE: In the **Edit Patient Data** field, change the **Age Format** to months and enter the patient’s age in months, or enter the **Date of Birth**, and the Atria calculates the age automatically.

3. Verify the patient’s heart rate displays on the Home screen. If heart rate does not display, view problem leads on the display. Replace faulty electrodes as necessary.
4. Enter patient demographics.

NOTE: To acquire a stat ECG, press **[ECG]** and then press **[Select]** or **[ECG]** to select **Acquire STAT ECG for a new patient**.

5. Press **[ECG]**.
6. Use the navigation buttons to display **Acquire ECG, current patient data** then press **[Select]**.

ECG Reports

The Atria automatically includes a formatted 12-lead report with demographics in any ECG printout. Additionally, an Atria with the optional interpretation feature automatically prints the interpretive analysis on the report (this feature can be disabled).

The Atria can also automatically print the following pages with the ECG:

- Rhythm page
- Copies of ECG, with or without analysis
- Median complex report (interpretive Atria only)

For more information on enabling these reports, or to disable automatic printing, see “Report Format” on pg. 4-2.

Plain Paper Printing

The Atria can be configured to print ECGs to a plain paper printer.



Caution

Data loss. Always check plain paper printouts before disconnecting the patient and ending the procedure.

Printing Problems (Thermal Printer)

If the Atria runs out of paper or if the paper jams while printing an ECG, either reload the paper and continue printing, or press **[Stop]** to save the record without printing.

For paper loading instructions see “Loading Recording Paper” on pg. 2-5 or press **[ALT] + [H]** to access the **Help** menu and then select **Loading Paper**.

Saving Reports

The Atria automatically saves ECGs. If the Atria is set up for network access, the ECG can also be automatically sent or emailed. For more information, see “Sequence” on pg. 4-5.

NOTE: To disable automatic saving of ECG reports, see “Auto Save” on pg. 4-5.

After the ECG has been saved, the **Patient Review** menu is displayed. See “How to Display a Patient Record” on pg. 8-2.

ECG Tips

Patient Data and Interpretation

- Enter all patient information. Some patient information directly affects ECG analysis. The physician uses this information when interpreting ECG reports. Also, an interpretive Atria provides more accurate and complete analysis statements when patient information is complete.
- Enter patient information at any time (either before or after the ECG). Changing age, gender, race, medication or clinical classification after acquisition, causes the interpretive Atria to prompt to reanalyze the data. Any changes in interpretation are included in future printouts. If the data is not reanalyzed, edits are not saved.

Acquiring a Clean Trace

- To obtain a clean trace with very little noise, ensure **Wait for Good Data** is set to **ON** in the **ECG** menu. If there is a problem during a recording, the Atria displays a message. If necessary, override the error message and continue recording by pressing the **[ECG]** key again (for more information, see “Wait for good data” on pg. 4-5).

NOTE: If **Wait for Good Data** is set to **ON** in the **ECG** menu, then it is possible to press **[ECG]** prior to connecting the patient. The Atria waits until all leads are connected and the acquired ECG traces settle (the Atria detects good data) before automatically starting the ECG.

Change Recorder Speed, Gain, Frequency Response

To temporarily change print settings for the current patient use the following shortcuts:

| Key | Description | Selections |
|------------|---|--|
| [7] | Select paper speed | 12.5 mm/s 25 mm/s 50 mm/s |
| [8] | Selects the ECG gain | 5mm/mV 10 mm/mV 20 mm/mV L10,C5 mm/mV L20, C10 mm/mV |
| [9] | Toggles the upper ECG filter frequency response | 40 Hz 150 Hz |

NOTE: The updated settings remain in effect until changed again or the Atria is restarted.

Acquiring a Rhythm Report

The Atria does not save rhythm report data.

1. Select the leads:
 - Keys **[1]** through **[4]** select preconfigured lead groups.
 - Keys **[5]** and **[6]** select user-customized lead settings. For more information, see “Custom Lead Settings” on pg. 4-9.
2. Press **[Auto Rhythm]** to print a rhythm strip for a predefined number of pages. See “Rhythm” on pg. 4-9.
3. Press **[Manual Rhythm]** to print a manual rhythm strip. Press **[0]** to place a 1 mV simulated calibration pulse on the printout.
4. To stop printing:
 - Press **[Stop]** to cancel printing at any time.
 - Press **[ECG]** to interrupt printing and begin another report.

Acquiring an ECG Using Alternative Lead Placements

The Alternate Chest Lead ECG allows acquisition of right chest leads and expanded left chest leads.

The standard ECG is an important part of the Alternate Chest Lead ECG. If acquiring an Alternate Chest Lead ECG, run a standard resting ECG before continuing (for more information, see “Acquiring a Stat ECG” on pg. 7-1).

Configure either CUSTOM LEAD 1 or CUSTOM LEAD 2 for the desired lead placement (see “Custom Lead Settings” on pg. 4-9).

1. Prepare the patient (See “Patient Preparation” on pg. 6-2.).
2. Attach electrodes according to the specific instructions for each lead configuration (see “Alternative Lead Placements” on pg. 6-8).
3. Press the **[5]** or **[6]** key to select the custom lead format.

NOTE: If alternate chest lead is selected, then **Alternate Chest Electrodes** displays on the **Home** screen. The message **Alternate Chest Lead ECG** or **RIGHT CHEST LEAD ECG** prints in place of the interpretation. Additionally, Atria uses the alternate chest lead format for standard and rhythm printouts until another custom lead format is selected.

4. Verify the patient’s heart rate displays on the **Home** screen. If the Atria does not display the heart rate, check the problem leads listed on the display. Replace faulty electrodes if necessary.
5. Press **[Auto Rhythm]** or **[Manual Rhythm]**.

NOTE: To obtain an alternate chest lead ECG, press **[ECG]**. The printout will be in the current configured ECG format using the selected leads.

Patient Demographics

WARNING



Misdiagnosis. Some patient information directly affects ECG analysis. Your patient's physician uses this information when interpreting ECG reports. Likewise, an interpretive Atria provides more accurate and complete analysis statements when you enter complete patient information.

- Press **[Patient]**.
 - To enter a new patient: select **Enter New Patient** and enter patient demographics.
 - To change an existing patient: select **View Patient Directory** and select a patient from the list to **Edit Demographics**.

NOTE: Recommended workflow is to enter patient information before acquiring an ECG, since this information affects both physician analysis and computer analysis.

The patient demographic fields are described on the following pages.

| Field | Description | Settings |
|----------------------|---|--|
| Patient ID | Enter a unique identifier for the patient. 20 characters | [text entry] |
| Last Name | Patient last name. 20 characters | [text entry] |
| First Name | Patient first name. 20 characters | [text entry] |
| Date Of Birth | Enter Year (4 digits), Month (2 digits), Day (2 digits). Date of Birth automatically enters Age and *Age Format . | [text entry] |
| Age | 3 numeric characters (range = 0-129 years, 0-99 months, 0-365 days) Not editable if Date of Birth was entered. | [text entry] |
| Age Format | Not editable if Date of Birth was entered. | YEARS MONTHS DAYS |
| Gender | Enter the gender of the patient. | blank MALE FEMALE |

| | | |
|---------------------|--|---|
| Race | Enter the patient's race. | blank BLACK CAUCASIAN ASIAN OTHER RACE UNKNOWN |
| Medication 1 | Select medication taken by the patient. | blank NO MEDICATION UNKNOWN DIGITALIS DIURETIC BETA BLOCKER QUINIDINE PROCAINAMIDE AMIODARONE DISOPYRAMIDE LIDOCAINE OTHER ANTIARRHYTHMIC PSYCHOTROPIC STEROID CALCIUM BLOCKERS NITRATES ACE INHIBITORS ALPHA BLOCKERS OTHER MEDICATION |
| Medication 2 | This field is not displayed if Medication 1 is left blank, or NO MEDICATION, UNKNOWN, OTHER MEDICATION is selected. | [see MEDICATION 1 list above] |
| Class 1 | Patient's cardiac, lung, or endocrine conditions. For ECG waveform analysis, it is better to select NORMAL or UNKNOWN than to leave this field blank. | blank NORMAL UNKNOWN MYOCARDIAL INFARCTION MYOCARDIAL ISCHEMIA HYPERTENSION CONGENITAL HEART DISEASE RHEUMATIC HEART DISEASE PERICARDITIS RESPIRATORY DISEASE IMPLANTED PACER ENDOCRINE DISEASE PULMONARY EMBOLISM POST CARDIAC SURGERY CARDIOMYOPHTHY OTHER |
| Class 2 | This field will not appear if Class 1 is left blank, or NORMAL, UNKNOWN, OTHER is selected. | [see CLASS 1 list above] |
| Height | Enter height using the units displayed. Enter up to 3 numeric characters. (Range = 0-96 in. or 0-244 cm) | [text entry] |

| | | |
|---------------------|---|---------------------|
| Weight | Enter weight using the units displayed. Enter up to 3 numeric characters. (Range = 0- 550 lb. or 0-249 kg.) | [text entry] |
| Systolic BP | Enter the systolic blood pressure limit. Enter up to 3 numeric characters. (Range = 0 – 250) | [text entry] |
| Diastolic BP | Enter the diastolic blood pressure limit. Enter up to 3 numeric characters. (Range = 0 – 250) | [text entry] |
| Department | Enter a department number to identify your department within a facility. Enter up to 5 numeric characters. (Range 1 – 32000) | [text entry] |
| Room | Enter a room number to identify your location within a facility. Enter up to 7 alphanumeric characters | [text entry] |
| Technician | Enter the name of the technician who acquired the ECG. Enter up to 20 alphanumeric characters. | [text entry] |
| Physician | Enter the name of the patient's physician. Enter up to 20 alphanumeric characters. | [text entry] |
| User Field | A user-defined field. You may label this field; see "Patient Settings" on pg. 4-11. A possible use might be to identify the referring physician. Enter up to 15 alphanumeric characters. | [text entry] |
| V3 Placement | Use only for pediatric reports. For more information on pediatric lead placement, see "Pediatric Lead Placement" on pg. 6-8. | STANDARD V4R |
| Comments | Use this field to input additional patient information as needed. Enter up to 25 alphanumeric characters. | [text entry] |

Working with Patient Records

Use the **Directory** menu to create new patient records, access existing records, or to work with some or all patient records at once. You can use the **Directory** menu to print a directory report, print ECGs, create demographic records, and delete patient records.

To access the **Directory** menu:

1. Press **[Home]** and then press **[Directory]**.
2. Press **[Next]** or **[Previous]** to scroll through the directory options:
 - **View Entire Patient Directory**—Lists all the saved patient records
 - **View Open Orders**—Lists only demographic-only records (no attached ECG).
 - **View Pending Records**—Lists only records that have not completed their lifecycle on the device.

NOTE: Pending records are demographic-only records, records marked as **Hold**, or records that have not been printed (if communication is disabled), or records that have not been sent (if communication is enabled).

- **Enter New Patient**—Creates one or more patient files before recording ECGs. (For more information, see “Enter Patient Demographics” on pg. 7-2).
- **Print All New ECGs**—Print all ECGs in the directory not yet printed (their Record Status is not **Pr**).
- **Print Entire Directory**—Prints all records in the directory.
- **Print Open Orders**—Prints only demographic-only records (no attached ECG).
- **Print Pending Records**—Prints only records that have not completed their lifecycle on the device.
- **Show Directory Status**—Shows all demographics-only, unprinted, or unsent records.

NOTE: If **Show Directory Status** is not listed in the directory, then the directory does not contain demographics-only, unprinted or unsent records

- **Delete All Records**—Permanently deletes all records.



Caution

Data loss. Deleting a patient record permanently removes the record. Once deleted, a record can not be recovered.

How to Display a Patient Record

1. Press **[Home]** and then press **[Directory]**.
2. Select **View Patient Directory** and then select a patient.

The **ECG Review** menu displays.

NOTE: The system also automatically displays the **ECG Review** menu after taking an ECG.

NOTE: Additional communications menu items may be displayed, depending on the options available and set up. See “Communications Setup” on pg. 5-1.

3. Press **[Select]** to select the displayed option.
 - **Acquire New ECG on Same Patient**—The Atria acquires a new ECG using the current patient’s demographics.
 - **Print copy of this ECG**—Prints a copy of the saved ECG.

NOTE: If the directory contains additional unprinted ECGs, a prompt is displayed to print all unprinted ECGs or only the current ECG.

- **Print Plain Paper ECG**—Only available if a external printer has previously been configured.
- **Edit Demographics**—Update patient demographics. For more information on patient demographic fields, see “Patient Demographics” on pg. 7-7.

NOTE: If you edit age, gender, race, medication, or clinical classification after acquisition, an interpretive Atria provides the option to reanalyze the data. Any changes in interpretation are included in future printouts. If you do not reanalyze the data, edits are not saved.

- **Change Speed, Gain, or Filter**—Change printer speed, signal gain, or filter settings. Print settings for saved records can be changed once the record is reprinted (changes affect the selected record only).

NOTE: These settings can be changed at the **Home** screen using the **[7]**, **[8]**, or **[9]** keys before ECG acquisition.

- **Print Median Complex Report**—To review the averaged beats for a record on an interpretive Atria, the median complex is used as the basis for all computerized analyses.

NOTE: Chart speed is fixed at 50 mm/s and the artifact filter is always off.

- **Print Measurement Matrix**—To review the numerical data for a record. The measurement matrix contains numerical data, such as P wave duration (“PDUR”) derived from the median complex for the record.

NOTE: This report is available on an interpretive Atria only. For detailed information on this report, see “Measurement Matrix” on pg. 12-1.

- **Print Rhythm Report**—Prints a rhythm report (12-leads, all 10 seconds of the ECG data).
- **Show Status**—Shows the date and time of the record and record status. The status of a record is important, especially when transmitting to an EMR system. Record status determines which records are retained if the directory becomes full (see “Automatic deletion when the Directory is full” on pg. 8-6).

The table below details record status codes:

| Code | Record Status | Detail |
|---------------|----------------------|--|
| Demogr | Demographics Only | The record contains only patient demographic information. The record does not contain an ECG report. |
| Order | Downloaded Order | The record is downloaded, unfilled (demographics-only) order from the EMR System. |
| ECG | 12-Lead | The record contains a 12-lead ECG. |
| RtE | Alternate Chest Lead | The record contains an Alternate Chest Lead (non-standard) ECG. |
| Pr | Printed | The ECG record has been printed by the Atria electrocardiograph. |
| St | Sent | The record has been sent to an EMR system or a network location. |
| Rv | Received | The record is an ECG downloaded from the EMR System. |

| Code | Record Status | Detail |
|------|---------------|--|
| Hold | Hold | Prevents sending the record if Send All New or Selected ECGs is selected. Prevents auto-deletion of the record. |

- **Delete Record**—Deletes the selected patient record.



Caution

Data loss. Deleting a patient record permanently removes the record. Once deleted, a record can not be recovered.

Enter New Patient

To create one or more patient files prior to recording any ECGs, use the **Enter New Patient** selection in the directory. This feature allows you to input demographics into the directory in advance of taking an ECG, which later reduces the time required to acquire the report.

1. Press **[Directory]**.
2. Press **[Next]** to scroll to **Enter New Patient**.
3. Press **[Select]**.
4. The **DisplayMenu>Edit Patient Data** display appears. Enter the patient's ID number, last name, first name, date of birth, gender, and as many other fields as required or as time will allow.

Atria automatically creates a file for the patient.

Print Directory

To print all patient records currently stored in the directory, select the **Print Directory** option in the directory.

1. Press **[Directory]**.
2. Press **[Next]** to scroll to **Print Directory**.
3. Press **[Select]**.

Atria prints all the records in the directory (see sample printout in Chapter 9).

Print All New ECGs

To print all ECGs in the directory which have not been printed yet (i.e., Record Status is not PR), select the **Print All New ECGs** option in the directory.

1. Press **[Directory]**.
2. Press **[Next]** to scroll to **Print All New ECGs**.
3. Press **[Select]**.

Atria prints all ECGs which have not printed previously.

Show Directory Status

To view a sum of all unprinted, unsent (with the communications option), or demographics-only records, use the **Show Directory Status** option in the directory.

NOTE: If **Show Directory Status** is not listed in the directory, then the directory does not contain demographics-only, unprinted, or unsent (with the communications option) records.

1. Press **[Directory]**.
2. Press **[Next]** to scroll to **Show Directory Status**.
3. Press **[Select]**. Atria displays total number of unprinted records.
4. Press **[Next]** to display total number of demographics-only records.
5. To print unprinted records, scroll to **Records to print** and press **[Select]** twice. Or, scroll to **ECGs to Acquire** and press **[Select]** twice.

The list of records in the directory displays, with the demographics-only records listed first.

6. To send unsent records, scroll to **Records to send** and press **[Select]** twice.

Delete All Records

NOTE: The below information is for use by authorized personnel only.

With Atria, it is possible to delete all contents in the directory.



Caution

Data loss. Deleting a patient record permanently removes the record. Once deleted, a record can not be recovered.

1. Press **[Directory]**.
2. Press **[Next]** to scroll to **Delete All Records**.
3. Press **[Select]**.
4. **Loss of Data.** Continuing with the following steps will permanently erase all saved records. To cancel the request and return to the **Directory** menu, press **[Select]**.
5. Press **[Next]**.
6. Press **[Select]**.
7. Press **[Next]**.
8. Press **[Select]**.

Automatic deletion when the Directory is full

If you create a new record when the directory is full, the Atria deletes an older record to make room for the new record. There are rules based on record status which determine which records are automatically deleted. The oldest record with the proper status is deleted.

Atria without communication options:

- If the Atria is not configured for communication with an EMR system, then any record with status **Pr** may be deleted.
- Records with status **Demogr** (demographics-only records) are never deleted.
- Records without status **Pr** (unprinted records) are never deleted.

Atria with communication options:

- If the Atria is configured for communication with an EMR system, then a record with status **St** may be deleted.
- Records with status **Demogr** or **Order** (demographics-only records) are never deleted.
- Records without status **St** (unsent records) are never deleted.
- Records with status **Hold** are never deleted.

A **Directory Full** message displays if a new patient is started and all records in the directory do not meet any of the automatic deletion criteria. A new record is allowed only if one of the following actions is taken:

- Print at least one unprinted record
- Send at least one unsent record (Atria with communication option only)
- Acquire at least one demographics-only record
- Delete at least one record from the directory

When the directory is full you may, however, obtain ECG printouts. These will not be stored in the directory unless storage space is available.

Communications Options

Sending ECG Records to an EMR System

NOTE: Using the send feature requires the communications option. See “Communications Setup” on pg. 5-1.

Use the send feature to send the record to either the EMR system or network share, based on the EMR connection setting (see “Setup EMR Communications” on pg. 5-12).

The Atria can send records in a batch or as all new records. Follow the instructions under “Send All New or Selected ECGs”.

Alternatively, you have can review each records to send. In reviewing the send status for each record, you have the option of placing individual records on hold, which prevents the record from being sent (until its status is changed again). To send selected records only, first follow the instructions under “Select Records to Send”, then continue with “Send All New or Selected ECGs”.

SEND ALL NEW OR SELECTED ECGS

1. Press [**Send/Rec**].
2. Press [**Select**].

Atria displays the status of the transmissions.

SELECT RECORDS TO SEND

This menu allows you to review each record for send status. For each record, you may select to send or place the record on hold. The send status defaults to send. You may change the send status for a record at any time.

1. Press **[Send/Rec]**.
2. Select **Select Records to Send**.
3. Review send status.
4. To change send status:
 - a. Select the record to change status.
 - b. Select **Hold** or **Send** and press **[Select]**.

Fax a Patient Record

WARNING



Misdiagnosis. ECG reports images viewed or printed in .pdf format at a size other than 100% may be appear distorted.

Also, records sent by fax may not be suitable for diagnostic use due to the low resolution of some fax receiving equipment.

Patient records can only be faxed if the fax option is enabled and properly set up. Refer to the beginning of Chapter 5 for general communications setup and “Setup Fax” on pg. 5-10.

1. Press **[Home]**.
2. Press **[Patient]**.
3. Select **View Patient Directory**.
4. Scroll down and select the desired patient.

The **ECG Review** menu displays.

5. Select **Fax ECG**.
6. Select the desired fax destination.

Email a Patient Record

WARNING



Misdiagnosis. ECG reports images viewed or printed in .pdf format at a size other than 100% may be appear distorted.

Also, records sent by fax may not be suitable for diagnostic use due to the low resolution of some fax receiving equipment.

Patient records can only be emailed if the email option is enabled and properly set up. Refer to the beginning of Chapter 5 for general communications setup and “Setup Email” on pg. 5-10.

1. Press **[Home]**.
2. Press **[Patient]**.
3. Select **View Patient Directory**.
4. Scroll down and select the desired patient.

The **ECG Review** menu displays.

5. Select **Email ECG**.
6. Select the desired email destination.

Retrieving ECG Records and Orders from an EMR System with Web Services

NOTE: Using the record retrieval feature requires communications option. See “Communications Setup” on pg. 5-1.

Use the record retrieval feature to receive ECG record or orders from the EMR system, based on the EMR connection setting (see “Set up Web Services” on pg. 5-12).

Follow the instructions below to retrieve records from an EMR system such as Heartcentrix[®] or the Pyramis[®] ECG Database Management system (version 6.1 or later) or other compatible data management system.

If the EMR system supports order entry, then the Atria can retrieve orders from this system.

RETRIEVING ORDERS

1. Press **[Home]**.
2. Press **[Send/Rec]**.
3. Select **Get Patient Orders**.
4. Specify the criteria for the orders:

NOTE: Entries are not case sensitive.

- a. To receive all current orders, leave all fields blank.
 - b. To receive orders for a given department only, select the appropriate department.
 - c. To receive a specific order, enter the order number in **Order #**.
 - d. To receive orders for a specific patient, enter the patient ID (MRN) in **ID#**.
5. Press **[Send/Rec]**.

After a few seconds the Atria displays a list of all orders that meet the criteria specified above.

6. Select the orders:
 - a. To select all records, hold down **[Alt]** and then press **[1]**.
 - b. To de-select all records, hold down **[Alt]** and then press **[2]**.
 - c. To select or de-select individual records, highlight the record and press **[Select]**.

Selected records display with a brace (Atria 3100) or a checkmark (Atria 6100) in front of the record.

7. Press **[Send/Rec]**.

After a few seconds the Atria begins downloading the records and indicates the progress of the download.

NOTE: If the system has previously downloaded orders that are not yet filled and these orders become obsolete, then the old orders are automatically removed from the system during this procedure. Obsolete orders are orders which have been cancelled, or orders that have already been fill by another electrocardiograph.

RETRIEVING ECG RECORDS

1. Press **[Home]**.
2. Press **[Send/Rec]**.
3. Select **Get ECGs**.
4. Specify the criteria for the orders:

NOTE: Entries are not case sensitive.

- a. To receive all ECG records available (up to the maximum directory size), leave all fields blank.
 - b. To receive all ECG records for a specific patient, enter the patient ID (MRN) or patient name.
5. Press **[Send/Rec]**.

After a few seconds the Atria displays a list of all ECG records that meet the criteria specified above.

6. Select the orders:
 - a. To select all records, hold down **[Alt]** and then press **[1]**.
 - b. To de-select all records, hold down **[Alt]** and then press **[2]**.
 - c. To select or de-select individual records, highlight the record and press **[Select]**.

Selected records display with a brace (Atria 3100) or a checkmark (Atria 6100) in front of the record.

7. Press **[Send/Rec]**.

After a few seconds, the Atria begins downloading the records and indicates the progress of the download.

NOTE: If the Atria reports errors, the communications log contains more information regarding the errors. To print the communications log: Press **[Setup]** and then select **Print Communications Log**. For more information, press **[ALT] + [H]** to access the **Help** menu and select **Troubleshooting > Communications**.

NOTE: The sample reports in this chapter are from the Atria 6100. They are identical to the reports for the Atria 3100.

Setup Report

The Setup Report is a list of all current settings. The sample Setup Report printouts (below and following page) lists the settings as they are set at the factory.

Setup:Waveform Preferences
Speed: 25 mm/s
Gain: 10 mm/mV
Artifact Filter: 40 Hz
Baseline Filter: STABLE Baseline
Line Filter: ON
Pacer Enhancement: OFF
Lead Group: Custom 1

Setup:Directory
View Directory: View By Id
Setup:Auto Rhythm
Auto Rhythm Pages: 1

SETUP REPORT Page 1/2
08/11/2006 12:48:24

Setup:System
User 1-2 Select: 1
Date Format: MM/DD/YYYY
Date: 08/11/2006
Time: 12:48:24
Language: English
Height Units: IN.
Weight Units: LB.
Inst. Name:

Setup:ECG:Report Format
12 Lead Format: STANDARD 4 CHANNEL

| | | | | | | | | | | | | | | | | | | | | | | | | | | | | | | | | | | | |
|--------------------------------------|---------------------------|-------------------------------|------------------------------|---------------------------|------------------------|----------------------------|-------------------------------|----------------------------|--------------------|------------------------|---------------------|-----------------------|-------------------------------|----------------------------|----------------------------|---------|----------------|------------|----------|------------------|-------------------|-------------|--------------|-------------|-------------|------------------|-------------------|-----------------|-----------|-----------------------|----------------------|-----------------|-------------------|-------------|--|
| Paper Type: Assurance | Paper Size: A (8.5 x 11) | Administrative Password: OFF | Diagnostic Password: OFF | AC Mains Frequency: 60 Hz | Battery Saver Mode: ON | Battery Saver Timeout: 900 | Keyboard Revision: Revision 2 | Adjust Contrast | Setup:Patient | Custom Header ID: 0000 | Custom Header Name: | Default Custom Header | Last Name: ON | First Name: ON | Date of Birth: ON | Age: ON | Age Format: ON | Gender: ON | Race: ON | Medication 1: ON | Medication 2: OFF | Class 1: ON | Class 2: OFF | Height: OFF | Weight: OFF | Systolic BP: OFF | Diastolic BP: OFF | Department: OFF | Room: OFF | Technician: ON; CLEAR | Physician: ON; CLEAR | User Field: OFF | V3 Placement: OFF | Comment: ON | |
| Setup:ECG:Interpretation Preferences | Analysis Statement: BRIEF | Print Interp. on Original: ON | Print Interp. on Copies: OFF | Bradycardia Limit: 60 | Tachycardia Limit: 100 | QTc Formula: Hodges | Setup:Custom 1 | Custom 1: CUSTOM 3-CHANNEL | Channel 1: LEAD II | Channel 2: aVF | Channel 3: VS | Setup:Custom 2 | Custom 2: STANDARD 12-CHANNEL | Setup:Printhead Resistance | Printhead Resistance: 107% | | | | | | | | | | | | | | | | | | | | |

Serial #A3100-000000
Atria 3100 Int. rev#P0000007 #1.000.0000

BURDICK REORDER NO#REF 716-0237-00

BURDICK

Standard 12-Lead, 6-Channel ECG, Brief Statements

03/17/2006 9:20:26

Galiner, Deborah
ID: 1297764

D.O.B.: 12/02/1964 41 YEARS

FEMALE

Meds: DIURETIC

Class: UNKNOWN

Dr: Jenkins

Tech: Frederick

| | |
|----------------|-------------|
| Vent. Rate: | 90 bpm |
| RR Interval: | 666 ms |
| PR Interval: | 140 ms |
| QRS Duration: | 86 ms |
| QT Interval: | 310 ms |
| QTc Interval: | 362 ms |
| QT Dispersion: | 24 ms |
| P-R-T AXIS: | 33° 52° 54° |

Sinus rhythm
rS₁(V1) - probable normal variant
Left ventricular hypertrophy
Extensive ST-T changes may be due to hypertrophy and/or ischemia
* Unconfirmed Analysis *

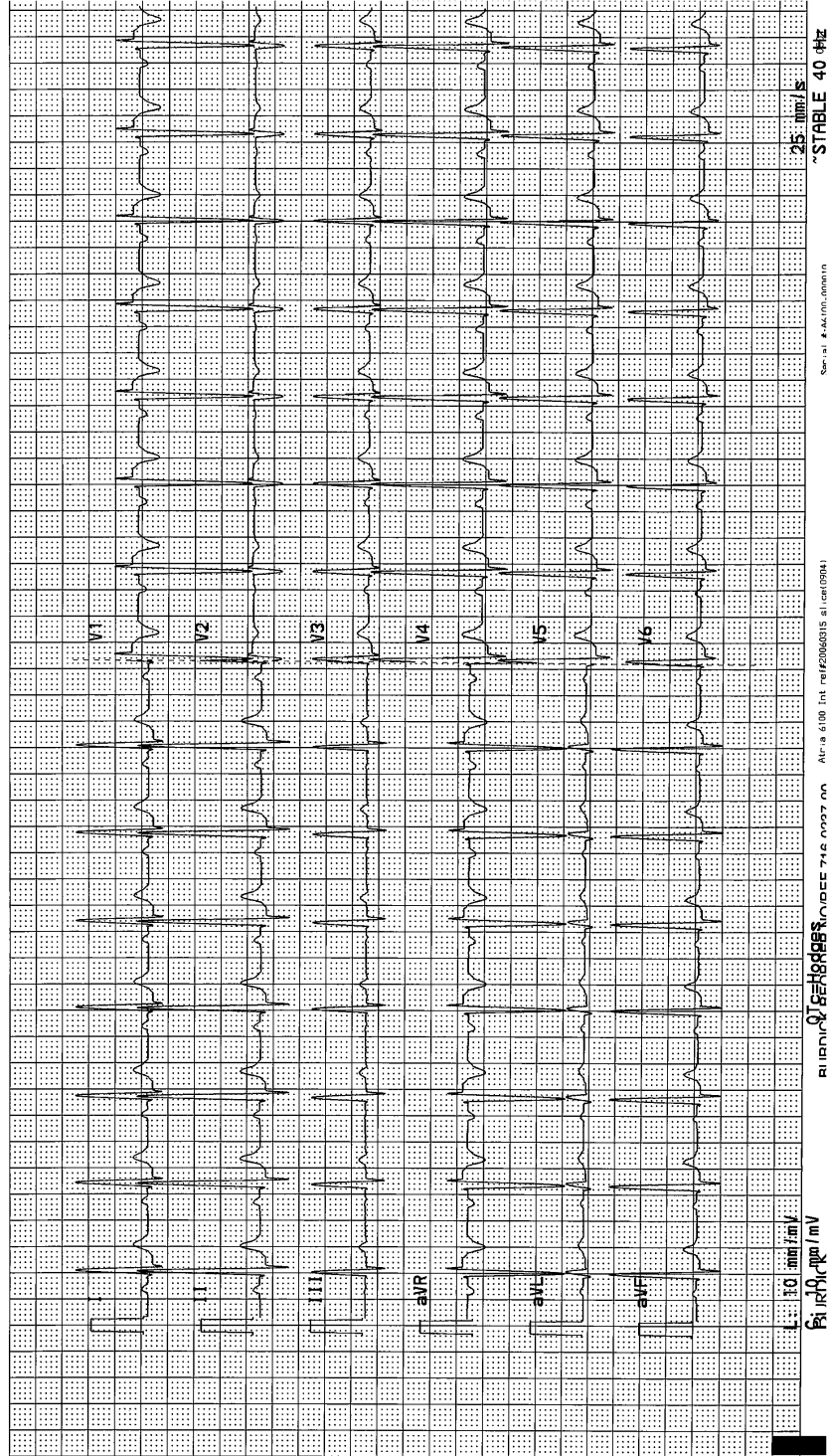

Median Complex, Brief Statements

03/17/2006 9:20:26

Sinus rhythm
 rSr'(V1) - probable normal variant
 Left ventricular hypertrophy
 Extensive ST-T changes may be due to hypertrophy and/or ischemia:
 Abnormal ECG * Unconfirmed Analysis *

Gallner, Deborah
 ID: 1297764

D.O.B.: 12/02/1964 41 YEARS

FEMALE

Meds: DIURETIC
 Class: UNKNOWN
 Dr: Jenkins
 Tech: Frederick

Vent. Rate: 90 bpm
 RR Interval: 666 ms
 PR Interval: 140 ms
 QRS Duration: 86 ms
 QT Interval: 310 ms
 QTc Interval: 362 ms
 QT Dispersion: 24 ms
 P-R-T AXIS: 33° 52° 54°

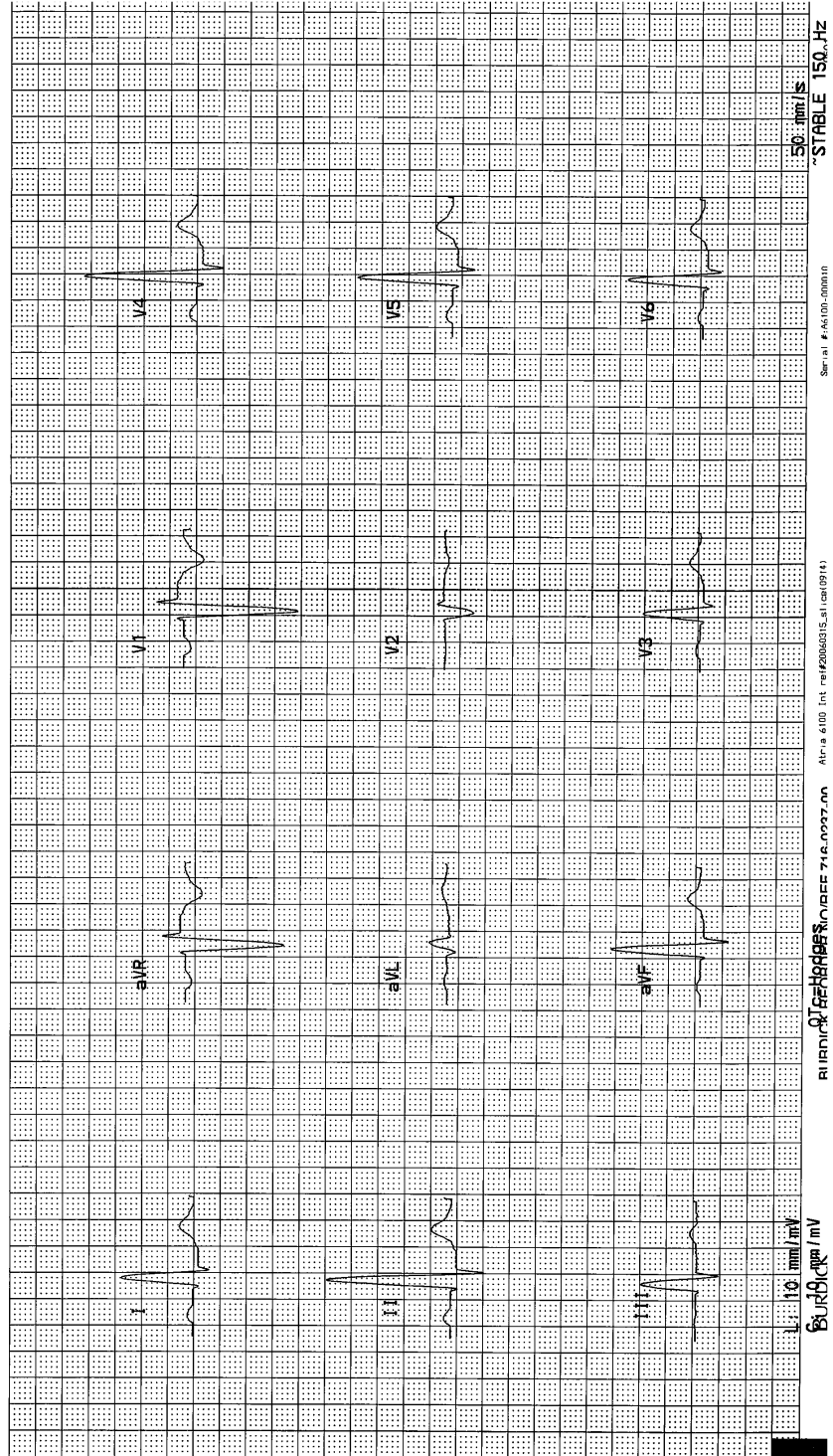

Serial #A4100-008010
 Atria 6100 Int. rev#20060315_41108(0914)
 RUIRRIQZ 66784665 0185EE 716.0097.00

Chapter **10** *Troubleshooting*

This chapter lists common problems and recommended solutions. For additional questions contact Cardiac Science Technical Support at (800) 777-1777 or (608) 764-1919.

Basic Troubleshooting

| PROBLEM | PROBABLE CAUSE |
|--|--|
| The Atria will not power up. | <ul style="list-style-type: none"> • The Atria is not connected to external power (refer to “Back Panel” on pg. 2-2 for connection information). • Battery is not installed or has no charge. • Faulty power cord. • AC outlet not functional. • Faulty external power supply. |
| The Atria beeps twice or emits abnormal beeping sounds. | <ul style="list-style-type: none"> • Function or key is not allowed (for example, the end of a list or field is reached). |
| The Atria has “frozen.” The Atria does not respond to key strokes and the display does not change. | <ul style="list-style-type: none"> • Press and hold the [On/Stby] key for five seconds or until the Atria shuts off. To continue with normal operation, press [On/Stby] again to restart the Atria. |
| The Atria display is completely blank. | <ul style="list-style-type: none"> • Press the [On/Stby] key to restart the Atria. If no response, verify the Atria is plugged in and press [On/Stby] again. • The Atria is in maintenance mode ([On/Stby] key was pressed twice when powering on). Press the [On/Stby] key once to restart the Atria. • Contrast is too light or dark. Press [Form Feed] to verify the Atria is on, and then press [Shift] + [Previous] to lighten the display or press [Shift] + [Next] to darken the display. |

| PROBLEM | PROBABLE CAUSE |
|--|--|
| The Atria will not send records via modem/fax function not working. | <ul style="list-style-type: none"> • Verify the Atria is connected to a phone jack. • Verify the Atria contains an internal fax/modem; contact your local representative or Cardiac Science Corp. Technical Support Department for assistance. • Verify the phone number and description fields are correctly filled in. These are found in the Setup > Send Receive > Setup FAX menu item. • Verify the correct phone type and connection type are selected in the Setup > Send Receive > Setup FAX menu item. • Verify the phone cord is functioning. |
| The Atria displays "Directory Full" message. | <ul style="list-style-type: none"> • Records in the directory are either demographics-only, have not been printed or have not been sent (with the communications option). See "Automatic deletion when the Directory is full" on pg. 8-6 for more information. |
| All printouts show Alternate Chest Lead ECG or RIGHT CHEST LEAD ECG. | <ul style="list-style-type: none"> • Custom 1 or Custom 2 is configured to Alternate Chest Lead. Configure setting to any other format (see "Custom Lead Settings" on pg. 4-9). |

Trace Problems

Before troubleshooting trace problems, ensure the following:

- Good quality electrodes are used
- The electrodes are not dried out
- The skin is properly prepared and the electrodes are applied correctly, with good contact to the skin
- Electrodes are not dirty
- Lead wires are securely attached to all electrodes
- The ECG cable is securely plugged into the Atria

| PROBLEM | PROBABLE CAUSE |
|--|--|
| Waveforms are flat for all leads and/or "OVERLOAD" message will not clear. | <ul style="list-style-type: none"> • Acquiring ECG too quickly. Pressing [ECG] twice prevents the Atria from waiting for good data before printing ECG. Press [ECG] one time only. • Faulty patient cable. • Electrical interference from an external source is causing noise spikes. |
| Waveform is flat for one or more leads (all others are OK) and/or "OVERLOAD" message will not clear. | <ul style="list-style-type: none"> • Acquiring ECG too quickly. Pressing [ECG] twice prevents the Atria from waiting for good data before printing ECG. Press [ECG] one time only. • Electrode is being pulled, tapped or pressed. • Faulty lead wire(s) or patient cable. |
| Baseline is drifting in waveform for one or more leads. | <ul style="list-style-type: none"> • Use of dissimilar sensors or sensors not recommended for use with the Atria. • Sensors need to sit longer on skin. |
| Trace is "noisy." The waveform is not a single, clean line. | <ul style="list-style-type: none"> • AC interference from lighting, cables, or equipment near patient. • Improper AC Mains Frequency setting in the System menu. • Improper Line Filter setting in Setup > Waveform Preferences. |
| Occasional noise or artifact in the waveform for one or more leads. | <ul style="list-style-type: none"> • Patient movement. • Muscle tremor noise. • Electrical interference. • Sensors need to sit longer on skin. • Ineffective Baseline Filter setting in Setup > Waveform Preferences. |
| Incorrect heart rate printed and/or displayed. | <ul style="list-style-type: none"> • Waveform is a bigeminal rhythm. • QRS amplitude and T wave amplitude are almost the same. |
| Incorrect or missing measurements on the printout. | <ul style="list-style-type: none"> • Undetermined P-wave or P-T coupling. • Unusual waveform pattern. |

Printing

NOTE: For information on troubleshooting your plain paper printer, refer to the printer's Operator Manual.

| PROBLEM | PROBABLE CAUSE |
|---|---|
| Paper jammed or misaligned. | <ul style="list-style-type: none"> The Atria not used for extended period of time with paper installed. Reload paper, see "Loading Recording Paper" on pg. 2-5. |
| Print quality is very light. | <ul style="list-style-type: none"> The Atria is being used with unapproved paper. Use only Cardiac Science Corporation -approved paper. Paper type in use is Assurance, but paper type selected in system settings is HeartLine. Change paper type in settings to Assurance (see "Paper Type" on pg. 4-13). |
| Print quality is very dark. | <ul style="list-style-type: none"> The Atria is being used with unapproved paper. Use only Cardiac Science Corporation -approved paper. Paper type in use is HeartLine, but paper type selected in system settings is Assurance. Change paper type in settings to Standard (see "Paper Type" on pg. 4-13). |
| Problems using full format paper. | <ul style="list-style-type: none"> Load paper (see "Loading Recording Paper" on pg. 2-5) Ensure the paper is at top-of-form by pressing [Form Feed] and waiting until the paper stops. If Out of Paper message is displayed, press [Select]. Press [Manual Rhythm]. When printing starts, press [Stop]. Again, press [Manual Rhythm]. When printing starts, press [Stop]. |
| Report is printing STAT in the Patient ID field of the report. | <ul style="list-style-type: none"> No patient last name and ID number was entered for the patient. |

Recognizing and Reducing ECG Artifacts

OVERLOAD message

Defibrillating the patient will interfere with the Atria sensors and may result in loss of the trace or erratic trace deflections. The **OVERLOAD** message indicates the waveforms may not be accurate.

An overload condition may also be caused by:

- Dried out electrodes
- Improperly prepared skin
- Improperly applied electrodes, with poor skin contact
- Dirty electrodes

The condition must be corrected before the overload condition clears.

Rapid, large and erratic deflections

A broken wire in the patient lead or a poorly applied sensor may cause rapid, large and erratic trace deflections.

Motion artifact

Patient movement and muscle tremor may result in abnormal traces. To minimize this artifact, toggle the artifact filter to 40 Hz, using the **[9]** key.

In addition, try to gain the patient's cooperation in staying very relaxed and still. Sometimes, somatic tremor is unavoidable but its effects may be minimized by having the patient place his/her hands under the buttocks.

Figure 10-1
Somatic Tremor and
Patient Movement Artifact

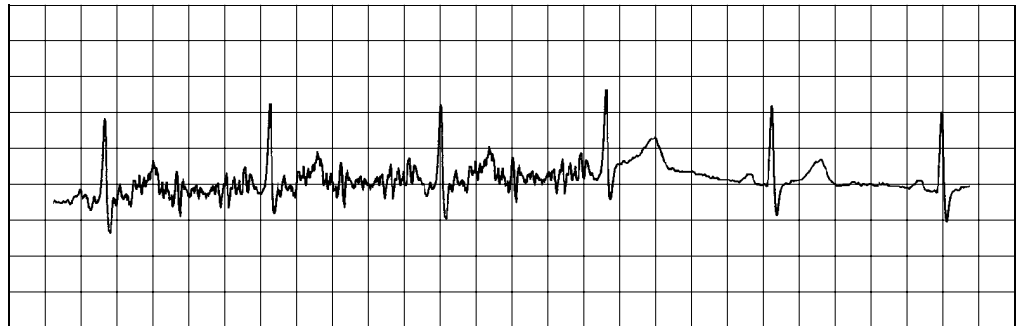

Baseline wander

Normally, the baseline will stabilize within a few seconds. The following conditions may also cause an baseline wander:

- Patient breathing
- Dried out or peeling off electrodes
- Improperly prepared skin
- Improperly applied electrodes, with poor skin contact
- Dirty electrodes
- Body motion

Fix the faulty electrode, or turn on the Stable Filter to correct.

Figure 10-2
*Poorly Affixed Sensor
Artifact*

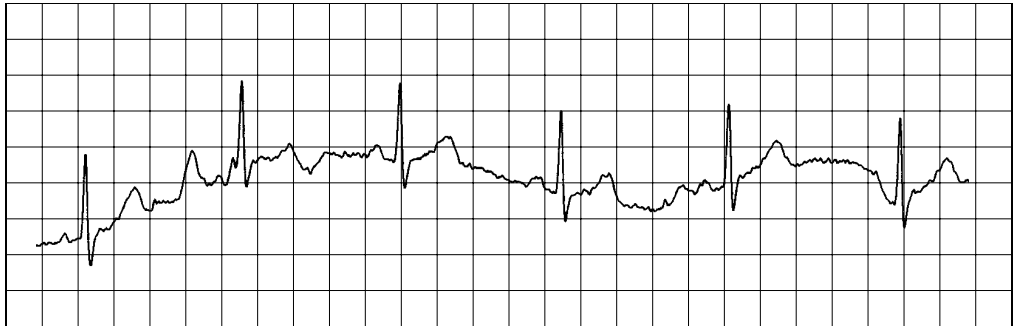

Electrical Interference

Electrical interference may produce a wide baseline. Its amplitude depends on the strength of the current source and the lead being recorded. In any one lead, the amplitude of the interfering signal is uniform.

Figure 10-3
*Electrical Interference
Artifact*

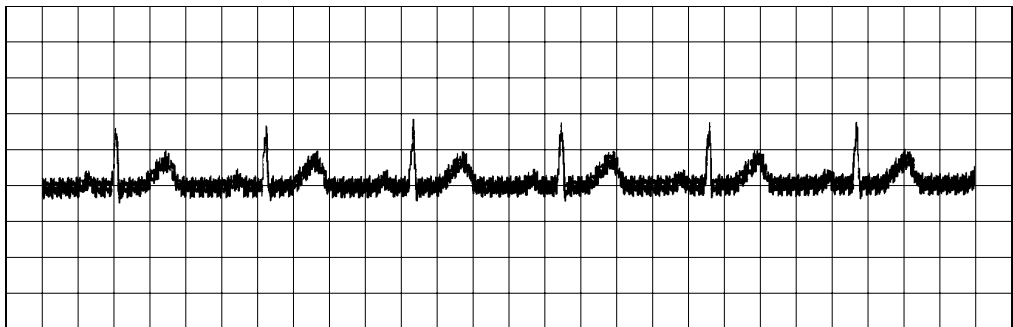

To reduce electrical interference:

- Keep the power cord away from the patient and patient cable.
- Connect the Atria to a properly grounded wall outlet.
- Arrange the patient cable leads together, closely following the body contour.
- Turn on line filter. Check **[Setup]** and then select **Waveform Preferences > Line Filter**. For more information, see “Line Filter” on pg. 4-8.
- Ensure Diathermy or X-ray equipment in adjacent rooms is not operating. Other electrical equipment including electric beds, televisions, and lighting fixtures may also generate interference (even when not in use).
- Try moving the patient to another place in the room. Sometimes, electrical wiring in walls and ceilings causes interference.
- Operate the Atria from battery power.

Chapter **11** *Maintenance and Service*

Cardiac Science Corporation recommends performing the following routine maintenance procedures per the schedule listed or as needed.

Once per Shift

Clean and Disinfect

Clean and disinfect the Atria at least once per shift, or as needed.

Caution



Equipment damage. Do not use ether, bleach, acetone, benzene, or similar solvents to clean the Atria, cables, or sensors.

Only use the following cleaning agents: 3M™ 23H, PDI® Nice Pak® Sani-System, or Virex II™.

Caution



Equipment damage. Do not immerse the Atria, cables, or sensors in any type of fluid.

If the Atria is immersed in, or comes in contact with, large quantities of fluid, immediately discontinue use and contact a qualified service technician.

Caution



Equipment damage. Do not hot sterilize Atria, cables, or sensors.

ATRIA EXTERIOR

To Clean and Disinfect:

- Use a clean damp cloth to apply a disinfectant listed above.

PATIENT CABLE AND REUSABLE SENSORS

To Clean and Disinfect:

- Use a clean damp cloth to apply a disinfectant listed above.

PRINTHEAD

Caution



Equipment Damage. Abrasive cleaners or harsh chemicals may damage the printhead.

If cleaning is required use a lint free swab dampened with isopropyl alcohol.

Check the printout to ensure the printing is legible and dark. Light printing (particularly at the baseline) may indicate a dirty printhead.

Inspect for Damage

WARNING



Hazardous voltage. The interior of the Atria may retain hazardous voltages even after the Atria is shut off and the power cord disconnected.

There are no internal user serviceable parts other than the battery. Do not remove any other cover or try to disassemble the Atria. If the Atria appears damaged, immediately discontinue use and contact a qualified service technician.

WARNING



Misdiagnosis. Operating a damaged Atria or using worn or damaged cables or connectors may cause incorrect or unreliable readings.

If the Atria appears damaged, immediately discontinue use and contact a qualified service technician.

Immediately replace worn or damaged cables or sensors.

Before each use, or at least once per shift, Check the Atria, cables, and sensors for wear or damage. This includes:

- **Atria housing**—Ensure the housing is clean and undamaged. Check for dents, bulges, or cracks.
- **Power cords**—(including the plugs, jacks and outlet). Ensure the power cords are not worn or damaged. Specifically, check for loose, cracked, or bent connectors at the plug ends and cuts, nicks, or fraying of the cords.
- **Wall outlet**—Check the wall outlet for cracks or other damage.
- **Other cables and sensors**—Check all other cables and sensors for loose, bent or cracked connectors and cuts, nicks or fraying of the cords.

Testing

The Atria performs a self-test at power up. No additional testing or calibration is necessary.

Check the Patient cable

If the patient cable appears damaged in any way (including nicks, cuts, bulging, or fraying), contact your local representative for replacement.

- Visually inspect the cable for cracks, stress marks and broken or bent pins.
- Connect the patient cable to the ECG and attach each sensor lead to an electronic heart signal simulator. (If a simulator is not available, a test subject may be used.)
- Check the signal transmission through the cable by flexing the cable and electrode lead wires and observing the ECG rhythm for irregular tracings.

NOTE: If using a test subject, be sure not to disturb the sensor site since common baseline artifact will occur. This should not be confused as a broken wire.

Testing the battery

The Atria automatically monitors battery status. No additional battery tests or calibration are required.

If the battery does not retain a charge for more than 30 minutes of operation, Refer to “Battery” on pg. 11-4.

WARNING



Fire or explosion. Never remove the battery pack and attempt to recharge using an external battery charger.

Annually

A complete safety and component check must be performed annually by a qualified service technician.

The testing must include a 1 mV calibration pulse test to verify the gain hardware is properly calibrated.

Component Replacement

The Battery and Patient Cable are the only user replaceable component on the Atria.

WARNING



Hazardous voltage. The interior of the Atria may retain hazardous voltages even after the Atria is shut off and the power cord disconnected.

There are no internal user serviceable parts other than the battery. Do not remove any other cover or try to disassemble the Atria. If the Atria appears damaged, immediately discontinue use and contact a qualified service technician.

Battery

WARNING



Fire or explosion. Never remove the battery pack and attempt to recharge using an external battery charger.

WARNING



Fire, explosion, or contamination. Properly dispose of batteries in accordance with local regulations. Burning, heating, or improper disposal may cause explosion, fire, or contamination.

Caution



Loss of data. The battery pack must be installed at all times for proper operation. Operating without a battery pack may result in lost data.

Caution



Patient injury. Do not remove the battery within the patient vicinity.

WARNING



Shock hazard. Verify the external power cord is disconnected before removing or replacing battery. A blank display is not a reliable indication of disconnected external power.

To replace the battery:

1. Disconnect external power.
2. Pull out the paper door and remove the paper.

Figure 11-1
*Atria Paper Tray
and Paper Removed*

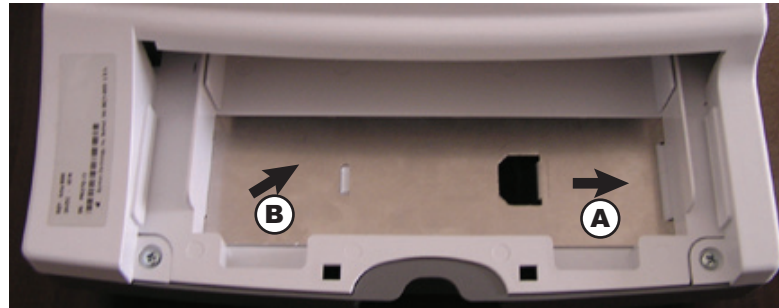

3. Remove the battery cover plate.
 - a. Slide the plate toward the front of the Atria.
 - b. Lift up the back end of the plate to remove.

Figure 11-2
*Removing Atria
Battery Cover Plate*

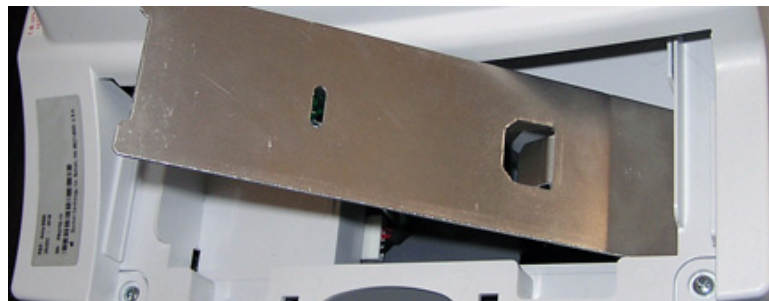
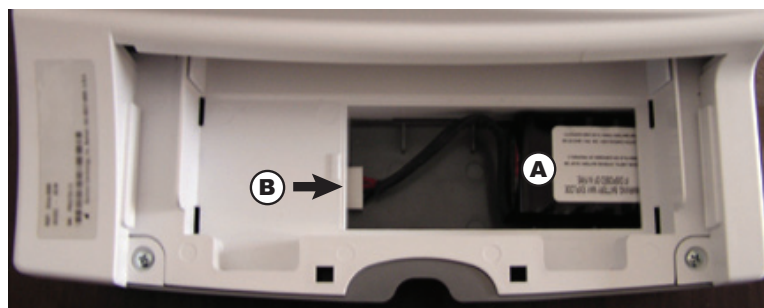

Figure 11-3
*Removing Atria
Battery Cover Plate*



4. Remove battery pack:
 - a. Slide the battery pack out of the battery compartment.
 - b. Disconnect the connector.

Caution



Equipment damage. Do not disconnect the plug by pulling the lead wires. This could cause loose or broken connections.

5. Insert the new battery into the battery compartment.

WARNING



Fire or explosion hazard. Use only an approved replacement battery pack. Replace the battery pack only with the battery specified on the label inside the battery compartment.

6. Slide the connector onto the jack. Ensure the plug is fully connected.

NOTE: Ensure the connector is oriented correctly. Do not force the connector onto the jack.

7. Slide the battery cover plate back into position (slide the front tabs in first).
8. Reload the paper and then replace the paper tray cover (see “Loading Recording Paper” on pg. 2-5).
9. Reconnect external power.

Notice to Responsible Service Personnel

The contents of this document are not binding. If you find a significant difference between this service information and your Atria, please contact Cardiac Science Technical Support. We reserve the right to improve or modify products without amending this document or advising the user.

We recommend consulting authorized personnel for all service and repairs, and using only approved replacement parts. Cardiac Science Corp. will not otherwise assume responsibility for material quality, workmanship, or any consequences thereof if approved replacement parts are not used.

This product has been carefully designed and manufactured to provide a high degree of safety and dependability. However, we can not guarantee against the failure or deterioration of components due to aging and normal use.

Performance Disclosures

WARNING



Explosion hazard. Do not use in the presence of flammable anesthetics, other gasses that support combustion, or in a high-oxygen atmosphere.

WARNING



Patient injury or death. Do not use the Atria for unattended or continuous patient monitoring. The Atria has no audible or visible alarms and change to patient condition may not be immediately known.

The Atria is only intended for short-term ECG waveform acquisition.

WARNING



Electromagnetic interference. Position the Atria away from other electrical or electronic equipment, if possible. The presence of strong EMI fields, or generated by RF noise on the line power, or by electronic, surgical, or diathermy instruments in close proximity to the Atria may cause trace noise or input overload conditions.

If used with, or around, other electrical or electronic equipment, always carefully monitor initial readings to verify normal operation.

The Atria is compliant with IEC 60601-1-2 EMC immunity requirements. Refer to “EMC Declaration Tables” on pg. 11-10.

WARNING



Misdiagnosis. U.S. Federal law restricts this device to sale by or on the order of a physician. The Atria must only be used by qualified operators and any results interpreted by a qualified diagnostician.

WARNING



False readings. The lead status check does not detect lead reversals. Always ensure the correct lead placement is used for the lead configuration selected.

NOTE: Deviations from the technical specification ranges listed can affect device performance.

The Atria is tested for IEC 60601-1-2 electromagnetic compatibility. The failure criterion for the device is, “undetectable interference with the ECG trace which could result in misdiagnosis.” While the device passes the relevant standards, it may exhibit evidence of interference when subjected to electrostatic discharges, high voltage transients or high voltage surges, as defined in IEC 801-2, IEC 801-4 and IEC 801-5. The interference from a single event will demonstrate as a sharp noise spike on the ECG trace. The clinician will not confuse such a noise spike with the heart beat waveforms and there is no hazard of misdiagnosis. In the unlikely situation the equipment is placed in an environment where such interference events are common, either the equipment or the interference source may be moved.

Battery pack

Under normal conditions, a fully charged battery pack provides adequate power to print a minimum of 300 pages of data at paper speed of 25 mm/sec; or a minimum of 55 minutes of continuous acquisition and printing.

A fully discharged battery pack will completely recharge in approximately 6 hours.

Heart rate detection

The Atria heart rate meter is specified to function in the range of 30 to 250 bpm with a tolerance of $\pm 10\%$ or ± 5 bpm, whichever is greater. Question marks (???) appear on the printout if the heart rate is out of the specified range.

WARNING



Patient injury or death. Do not use the Atria for unattended or continuous patient monitoring. The Atria has no audible or visible alarms and change to patient condition may not be immediately known.

The Atria is only intended for short-term ECG waveform acquisition.

40 Hz Artifact Filter



WARNING

Misdiagnosis. Using an artifact filter may affect the ECG output; the physician is responsible for taking this into account when reviewing and interpreting the ECG.

The primary purpose of the 40 Hz artifact filter is to remove skeletal muscle artifacts, i.e., undesired signals. The filter provides a better signal quality when high-frequency noise appears. However, the filter could also lower the peak of the QRS complex, as well as smooth some subtle details of ECG signals. For example, this may occur with left ventricular hypertrophy and with pediatric signals. The physician should take into account the effect of the artifact filter when reviewing such cases.

The 40 Hz artifact filter does not affect the automatic 12-lead measurement and interpretation analysis, but may affect the printed waveform. To view the full bandwidth signal for an ECG, change the artifact filter to 150 Hz; for more information, see “How to Display a Patient Record” on pg. 8-2. Additionally, you may change the default settings on your Atria to acquire new ECGs using the 150 Hz filter; refer to “Artifact Filter” on pg. 4-7.

Pacemaker Detection and Suspension

Unlike ECG signals, pacer signals are sharp and narrow impulses. External interference spikes sometimes mimic the shape of pacer impulses. Although this is a rare occurrence, it can obstruct accurate pacer detection.

When interference occurs, it causes an over-detection of possible pacer events, and could result in interpretation errors. Pacer detection suspension is designed to prevent possible interpretation errors due to interference for pacing patients. However, the detection suspension will not affect interpretation reports for patients who do not carry pacemakers.

NOTE: If spikes appear while pacer detection is suspended, refer to Chapter 10 for information on eliminating electrical interference. Once you have eliminated the source of the interference, proceed with ECG acquisition.

EMC Declaration Tables

WARNING



Electromagnetic interference. Position the Atria away from other electrical or electronic equipment, if possible. The presence of strong EMI fields, or generated by RF noise on the line power, or by electronic, surgical, or diathermy instruments in close proximity to the Atria may cause trace noise or input overload conditions.

If used with, or around, other electrical or electronic equipment, always carefully monitor initial readings to verify normal operation.

The Atria is compliant with IEC 60601-1-2 EMC immunity requirements. Refer to “EMC Declaration Tables” below.

The Atria is intended for use in the electromagnetic environment specified below.

Electromagnetic Emissions

| Emissions test | Compliance | Electromagnetic environment - guidance |
|---|------------|--|
| RF emissions CISPR 11 | Group 1 | The Atria uses RF energy only for its internal function. Therefore, its RF emissions are very low and are not likely to cause any interference in nearby electronic equipment. |
| RF emissions CISPR 11 | Class B | The Atria is suitable for use in all establishments. |
| Harmonic emissions IEC 61000-3-2 | Class B | |
| Voltage fluctuations/ flicker emissions IEC 61000-3-3 | Complies | |

Electromagnetic Immunity

| Immunity test | IEC 60601 test level | Compliance level | Electromagnetic environment - guidance |
|--|--|--|--|
| Electrostatic discharge (ESD) IEC 61000-4-2 | ±6 kV contact ±8 kV air | ±6 kV contact ±8 kV air | Floors should be wood, concrete or ceramic tile. If floors are covered with synthetic material, the relative humidity should be at least 30%. |
| Electrical fast transient/burst IEC 61000-4-4 | ±2 kV for power supply lines ±1 kV for input/output lines | ±2 kV for power supply lines ±1 kV for input/output lines | Mains power quality should be typical of a commercial or hospital environment. |
| Surge IEC 61000-4-5 | ±1kV differential mode ±2 kV common mode | ±1kV differential mode ±2 kV common mode | Mains power quality should be typical of a commercial or hospital environment. |
| Voltage dips, short interruptions and voltage variations on power supply input lines IEC 61000-4-11 | <5% U_T (<95% dip in U_T) for 0,5 cycle 40% U_T (60% dip in U_T) for 5 cycles 70% U_T (30% dip in U_T) for 25 cycle <5% U_T (<95% dip in U_T) for 5 sec | <5% U_T (<95% dip in U_T) for 0,5 cycle 40% U_T (60% dip in U_T) for 5 cycles 70% U_T (30% dip in U_T) for 25 cycle <5% U_T (<95% dip in U_T) for 5 sec | Mains power quality should be typical of a commercial or hospital environment. If the Atria user requires continued operation during power mains interruptions, then the Atria must be powered from an uninterruptible power supply or a battery. |
| Power frequency (50/60 Hz) magnetic field IEC 61000-4-8 | 3 A/m | 3 A/m | Power frequency magnetic fields should be at levels characteristic of a typical location in a typical commercial or hospital environment. |
| NOTE 1: U_T is the a.c. mains voltage prior to application of the test level. | | | |

| Immunity test | IEC 60601 test level | Compliance level | Electromagnetic environment - guidance |
|--|--|---|---|
| <p>Conducted RF IEC 61000-4-6</p> <p>Radiated RF IEC 61000-4-3</p> | <p>3 Vrms 150 kHz to 80 MHz</p> <p>3 V/m 80 MHz to 2,5 GHz</p> | <p>3 V^c</p> <p>3 V/m^c</p> | <p>Portable and mobile RF communications equipment should be used no closer to any part of the Atria, including cables, than the recommended separation distance calculated from the equation applicable to the frequency of the transmitter.</p> <p>Recommended separation distance</p> $d = 1.2 \sqrt{P}$ <p>$d = 1.2 \sqrt{P}$ 80 MHz to 800 MHz</p> <p>$d = 2.3 \sqrt{P}$ 800 MHz to 2,5 GHz</p> <p>where P is the maximum output power rating of the transmitter in watts (W) according to the transmitter manufacturer and d is the recommended separation distance in metres (m).</p> <p>Field strengths from fixed RF transmitters, as determined by an electromagnetic site survey,^a should be less than the compliance level in each frequency range.^b</p> <p>Interference may occur in the vicinity of equipment marked with the following symbol:</p>  |
| <p>NOTE 1: At 80 MHz and 800MHz, the higher frequency range applies.</p> | | | |
| <p>NOTE 2: These guidelines may not apply in all situations. Electromagnetic propagation is affected by absorption and reflection from structures, objects and people.</p> | | | |
| <p>^a Field strengths from fixed transmitters, such as base stations for radio (cellular/cordless) telephones and land mobile radios, amateur radio, AM and FM radio broadcast and TV broadcast cannot be predicted theoretically with accuracy. To assess the electromagnetic environment due to fixed RF transmitters, an electromagnetic site survey should be considered. If the measured field strength in the location in which the Atria is used exceeds the applicable RF compliance level above, then the Atria should be observed to verify normal operation. If abnormal performance is observed, additional measures may be necessary, such as reorienting or relocating the Atria.</p> <p>^b Over the frequency range 150 kHz to 80 MHz, field strengths should be less than 3 V/m.</p> <p>^c Amplitude modulated at 80% with a modulation frequency of 10 KHz per EN 60601-2-25.</p> | | | |

Recommended Separation Distances

Refer to the following table for recommended separation distances between the Atria and portable and mobile RF communications equipment.

The Atria is intended for use in an electromagnetic environment in which radiated RF disturbances are controlled. The user of the Atria can help prevent electromagnetic interference by maintaining a minimum distance between portable and mobile RF communications equipment (transmitters) and the Atria as recommended below, according to the maximum output power of the communications equipment.

| Rated maximum output power of transmitter W | Separation distance according to frequency of transmitter | | |
|--|---|---|--|
| | 150 kHz to 80 MHz $d = 1.2 \sqrt{P}$ | 80 MHz to 800 MHz $d = 1.2 \sqrt{P}$ | 800 MHz to 2,5 GHz $d = 2.3 \sqrt{P}$ |
| 0,01 | 0,12 | 0,12 | 0,23 |
| 0,1 | 0,38 | 0,38 | 0,73 |
| 1 | 1,2 | 1,2 | 2,3 |
| 10 | 3,8 | 3,8 | 7,3 |
| 100 | 12 | 12 | 23 |

For transmitters rated at a maximum output power not listed above, the recommended separation distance d in metres (m) can be estimated using the equation applicable to the frequency of the transmitter, where P is the maximum output power rating of the transmitter in watts (W) according to the transmitter manufacturer.

NOTE1: At 80 MHz and 800 MHz, the separation distance for the higher frequency range applies.

NOTE 2: These guidelines may not apply in all situations. Electromagnetic propagation is affected by absorption and reflection from structures, objects and people.

Technical Specifications

| | |
|-------------------------------------|---|
| Dimensions | 15.0" x 13.125" x 5.5" (381mm x 334mm x 140mm) |
| Weight (unit only) | 11 lbs (5 kg) (including external power supply) |
| Display | Atria 3100: 2 x 40 character backlit LCD screen Atria 6100: 640 x 480 backlit color LCD screen |
| Keyboard | Full alphanumeric keypad plus designated quick keys |
| Data Storage | Atria 3100: 50 records standard Atria 6100: 150 records standard, optional upgrade to 300 |
| Input Power | AC Operation 100-240 VAC \pm 10%, 50-60 Hz \pm 3 Hz |
| Battery duration | 55 minutes continuous printing |
| Printout | |
| Printout device | 216 mm thermal dot array |
| Paper dimension | 8.5" x 11" (US letter) 210mm x 300mm (A4) |
| Paper type | Thermal sensitive (Burdick Assurance [®] or HeartLine [™] paper recommended) |
| Chart speeds | 12.5, 25, 50 mm/sec |
| Gain | 5, 10, 20 mm/mV Chest or Limb (may be split) |
| Printout formats | 3, 4, 6 or 12 channels; additional rhythm formats |
| Acquisition | |
| Lead selection | I, II, III, aVR, aVL, aVF, V1, V2, V3, V4, V5, V6 and Alternate Chest Lead (chest lead selection V2R through V9R, V7, V8, and V9) |
| Modes | Automatic, automatic rhythm, or manual rhythm |
| Frequency response | Meets or exceeds ANSI/AAMI EC11-1991 and IEC 60601-2-51 standards |
| Input impedance | Meets or exceeds ANSI/AAMI EC11-1991 and IEC 60601-2-51 standards |
| Electrode offset tolerance | \pm 300 mV |
| Sampling | 8000 Samples/Sec. 2.5 μ V LSB |
| Artifact filter response | 40 Hz, -3db |
| Storage | 500 samples/second, 2.5 μ V LSB |
| Pacemaker display capability | Meets or exceeds ANSI/AAMI EC11-1991 standard and IEC 60601-2-51 |
| Interpretation (optional) | Diagnosis, measurements, reasons statements based on five demographic criteria |

Environmental

| | |
|---------------------------------------|---|
| Operating temperature | 50°F to 104°F (10°C to 40°C) |
| Operating relative humidity | 20% to 75% non-condensing |
| Operating atmospheric pressure | 1060 hPa to 700 hPa (-500 ft to 10,000 ft reference to sea level) |
| Storage temperature | -4°F to 113°F (-20°C to 45°C) |
| Storage relative humidity | 10% to 90% non-condensing |
| Storage atmospheric pressure | 1060 hPa to 190 hPa (-500 ft to 40,000 ft reference to sea level) |
| Harmful Ingress of Water | Normal |

Input/Output

| | |
|-----------------------------|-----------------------------------|
| (Units with communications) | Ethernet (RJ45) |
| | USB type A |
| | Standard RS-232 (9 pin D) |
| | Analog output (3.5 mm phono plug) |

Optional Upgrades

| |
|---------------------------------|
| 802.11 |
| Bluetooth |
| Telephone line interface (RJ11) |

Conforms to Standards

| |
|-----------------------------|
| CAN/CSA-C22.2 No. 0-M91 |
| CAN/CSA-C22.2 No. 601.1-M90 |
| CAN/CSA-C22.2 No. 601.1S1 |
| CSA C22.2 No. 601.2.25 |
| UL 60601 |
| EN 60601-1 |
| EN 60601-2-25 & Amend. 1 |
| EN 60601-1-2 |
| AZ/NZS 2064.1/2 |
| ANSI/AAMI EC11 - 1991 |
| EN 60601-2-51 |

Safety

| | |
|----------------------------------|---------------------------------|
| Leakage current | patient <10 µA, chassis <100 µA |
| Defibrillation protection | to 5000V, 360J |

Equipment Type

| | |
|---|---|
| Degree of protection from electric shock | IEC 60601-1 Class II, Type CF - Defibrillator Proof |
| Mode of operation | Continuous |

| | |
|-------------------|----------------------|
| Schematics | Available on request |
|-------------------|----------------------|

Warranty

| |
|--------------------------------------|
| 3 years with return of warranty card |
|--------------------------------------|

Chapter **12** *Measurement Matrix*

Atria models with interpretation and measurement capabilities also have the Measurement Matrix printing option. This option is available after acquiring the ECG via the **Patient Review** menu (see also “How to Display a Patient Record” on pg. 8-2 to print the measurement matrix using a saved patient record).

The Measurement Matrix consists of a column for each standard lead: I, II, III, aVR, aVL, aVF, V1, V2, V3, V4, V5, V6.

The following table explains the numerical values in the Measurement Matrix.

NOTE: Unless otherwise specified, all times are in milliseconds and all amplitudes are in microvolts.

| MEASUREMENT | Units | DESCRIPTION |
|-------------|-------|---|
| PON | ms | Time from the beginning of the representative beat to the beginning of the P wave. |
| PDUR | ms | P wave duration (total). |
| QRSON | ms | Time from the beginning of the representative beat to the beginning of the QRS complex. |
| QRS DUR | ms | QRS duration. |
| QDUR | ms | Q wave duration. |
| RDUR | ms | R wave duration. |
| SDUR | ms | S wave duration. |
| R'DUR | ms | R' wave duration. |
| S'DUR | ms | S' wave duration. |
| P+DUR | ms | P+ wave duration. |
| QRSDEF | ms | Intrinsicoid deflection time. |
| P+AMP | μV | P+ wave amplitude. |
| P-AMP | μV | P- wave amplitude. |
| QRSP2P | μV | Peak to peak amplitude of the QRS complex. |
| QAMP | μV | Q wave amplitude. |
| RAMP | μV | R wave amplitude. |

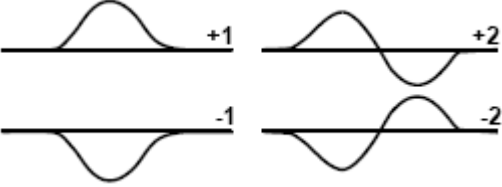
| MEASUREMENT | Units | DESCRIPTION |
|---|-----------------------------|---|
| SAMP | μV | S wave amplitude. |
| R'AMP | μV | R' wave amplitude. |
| S'AMP | μV | S' wave amplitude. |
| STAMP | μV | ST amplitude (at J point). |
| 2/8STT | μV | ST amplitude (at a point which is 2/8 of the ST-T interval). |
| 3/8STT | μV | ST amplitude (at a point which is 3/8 of the ST-T interval). |
| T+AMP | μV | T+ wave amplitude. |
| T-AMP | μV | T- wave amplitude. |
| QRSAR | $\mu\text{V}\cdot\text{ms}$ | Total area of the QRS complex (divided by 20). |
| TMORPH | | T wave morphology.  |
| RWNCH | | R wave notch count. |
| DWCON | % | Probability of the presence of a delta wave. |
| STSLOP | degrees | ST slope (horizontal = 0). |
| TON | ms | Time from the beginning of the recording to the beginning of the T wave. |
| TDUR | ms | T wave duration (total). |
| T+DUR | ms | T+ wave duration. |
| QTINT | ms | QT interval. |
| NOTE: Where ms is milliseconds and μV is microvolts | | |

Index

A

- AC mains frequency, 4-14
- AC power, connect, 2-2
- acquire ECG, 7-1
- acquire rhythm printouts, 7-6
- add patient, 8-4
- administrative password, 4-13
- alternate chest lead
 - acquire ECG, 7-6
 - configure, 4-10
 - placement, 6-8
- analysis options, 4-6
- artifact
 - electrical interference, 10-6
 - muscle, 10-5
- artifact filter
 - change current, 7-5
 - default setting, 4-7
 - performance disclosure, 40 Hz filter, 11-9
- automatic deletion, 8-6
- automatic information entry, 1-4

B

- baseline
 - filter, 4-8
 - wander, 10-6
 - wide, 10-6
- battery
 - charging, 2-4
 - testing, 11-3
- battery pack disclosure, 11-8
- battery saver setting, 4-14
- bradycardia limit, 4-6

C

- cable, patient
 - cleaning, 11-1
 - testing, 11-3
- cables, connect, 2-2, 2-3, 5-2
- cabrera
 - select custom, 4-10
 - select standard, 4-3

- calibration pulse, insert, 3-3
- change waveform settings
 - current, 7-5
- cleaning, 11-1
- communication options
 - setup, 5-1
- communication setup
 - 802.11, 5-4
 - certificates, 5-6
 - Ethernet, 5-3, 5-4
 - PPP, 5-6
 - supplicant configuration, 5-6
- configuration options, 4-1
- conforms to standards, 11-15
- connect patient cable, 2-3, 6-8
- contact information, 1-1
- contrast setting, 4-14
- copies, print, 8-2
- custom leads
 - configure, 4-9
 - select, 3-3
- customer service phone numbers, 1-1

D

- data quality filter, 4-5
- date format, 4-13
- Daylight Saving Time, 4-13, 5-4
- delete patient record, 8-4
- delete records, all, 8-6
- directory
 - add patient, 8-4
 - automatic deletion, 8-6
 - delete all records, 8-6
 - password protection, 4-14
 - settings, 4-12
 - status, 8-5
- directory full message, 8-6
- directory report
 - sample report, 9-2
- disclaimer, service, 11-7
- disclosures, 11-7
- disinfecting, 11-1
- disposable sensors, 6-5

E

- ECG
 - acquire, 7-1
 - acquire new using existing patient, 8-2
 - print copy, 8-2
 - print new, 8-4, 8-5
 - sample 3 channel rhythm, 9-7
 - sample 4 channel, 9-5
 - sample 6 channel, 9-6
 - troubleshoot artifacts, 10-5
- ECG reports, 7-3
- ECG tips, 7-4
- Edit Patient display, 3-8, 3-11
- electrical apparatus, multiple, 1-3
- electrolyte, 6-6
- e-mail
 - options, 4-5
 - setup, 5-10
- EMR system
 - retrieving ECG records, 8-11
 - retrieving orders, 8-10
 - sending records, 8-7
- environmental specifications, 11-15
- equipment
 - test, 11-3
 - type, 11-15
- equipotential grounding, 2-2
- Ethernet connection, 5-3, 5-4

F

- facility name setting, 4-13
- factory default settings, 9-3
- fax
 - setup, 5-10
- filter
 - artifact. See *artifact filter*
 - baseline, 4-8
 - data quality, 4-5
 - line, 4-8
 - STABLE Baseline, 4-8
- filter frequency
 - change current, 3-3
- frequency response
 - change current, 7-5
 - default setting, 4-7

G

- gain
 - change current, 3-3, 7-5
 - default setting, 4-7
- general features, 1-1
- GRI
 - See *interpretive analysis*
- grounding, 2-1, 2-2, 5-3

H

- heart rate
 - detection disclosure, 11-8
 - display, 3-7, 3-10
- help menu, 1-4
- home display, 3-7, 3-10
- hot keys
 - See *automatic information entry*
- housing, clean and disinfect, 11-1

I

- inspect for damage, 11-2
- inspection upon delivery, 1-1
- institution name setting, 4-13
- intended use, -v
- interference, 10-3, 10-6, 10-7
- interpretive analysis
 - configure, 4-6
 - general information, 1-2

L

- lead placement
 - alternate chest lead, 6-8
 - pediatric, 6-8
 - standard 12 lead ECG, 6-4
- leads, select custom, 3-3
- limb plates, 6-6
- line filter, 4-8
- low frequency response, 4-8

M

- maintenance, 11-1
- measurement matrix
 - print report, 8-3
 - sample report, 9-8
 - table (key), 12-1
- median complex

- print report, 8-3
- sample report, 9-9
- medical grade
 - power supply, 2-2, 2-3
- miscellaneous settings, 4-13
- modem, connect, 5-2
- multiple electrical apparatus, 1-3
- muscle artifact, 10-5

N

- network setup, 5-3

O

- options, configure, 4-1
- overload condition, 10-2, 10-5

P

- pacemaker
 - detection and disclosure, 11-9
 - enhancement setting, 4-8
- paper speed
 - change current, 3-3
 - default, 4-7
- paper, loading, 2-5
- paperless workflow, 1-4
- password protection, 1-3, 4-1, 4-13, 4-14
- patient cable
 - cleaning, 11-1
 - connecting, 2-3, 6-8
 - testing, 11-3
- patient demographics
 - configuring, 4-11
 - entering, 7-7
- patient records, 8-1
- Patient Review display, 8-2
- pediatric
 - acquire ECG, 7-3
 - lead placement, 6-8
- performance disclosures, 11-7
- phone numbers, 1-1
- power, 2-2, 2-3
 - cord, connect, 2-2, 2-3
 - indicator, 2-2, 2-4
 - medical grade, 2-2, 2-3
 - on and off, 2-3
 - standby mode, 2-3
 - status, 3-8, 3-10
- PPP communication, 5-6
- preparation

- patient, 6-1
- print new ECG, 8-4, 8-5
- print options, 4-5
- print settings
 - plain paper printer, 5-8
- printed reports, 7-3
- printer problems, 7-4, 10-4
- printhead, clean, 11-2
- printouts, samples, 9-1

Q

- QTc formula, 4-6

R

- record
 - delete, 8-4
 - print copy, 8-2
- record status, 8-3
- records
 - automatic deletion, 8-6
 - delete all, 8-6
- records, saved, 8-1
- reusable sensors, 6-6
 - cleaning, 11-1
- rhythm
 - acquire printouts, 7-6
 - configure, 4-9
 - sample 3-channel report, 9-7

S

- safety
 - features, 2-1
 - specifications, 11-15
- sample printouts, 9-1
- save options, 4-5
- saving ECG records, 7-4
- send
 - EMR or network share, 8-7
 - options, 4-5
 - status, 8-8
- sensors
 - disposable, 6-5
 - reusable, 6-6
- separation distances, recommended, 11-13
- serial cable, connect, 5-2
- settings, miscellaneous, 4-13
- Setup, 5-12
- Setup Patient menu, 4-11

Setup Printer menu, 5-8
setup report, 9-3
Setup Send Receive menu, 5-3
somatic tremor, 10-5
specifications, 11-14
speed
 change current, 7-5
 default setting, 4-7
STABLE Baseline filter, 4-8
standards, 11-15
standby mode, 2-3
Stat ECG, acquire, 7-1
status
 send, 8-8
 unprinted and demographics
 records, 8-5
Summer Time period. See *Daylight Saving Time*
supplicant configuration, 5-6
symbols, -vi
system settings, 4-13

T

tachycardia limit, 4-6
technical specifications, 11-14
testing equipment, 11-3
time setting, 4-13
tips, ECG, 7-4
trace problems, 10-2
troubleshooting, 10-1

U

units of measure settings, 4-13
upper frequency response, 4-7
user field settings, 4-12
user, select, 4-13

V

V3 placement, 4-12, 7-9

W

wait for good data, 4-5
warnings, -v
warranty, 11-15
waveform amplitude, 4-7

waveform settings
 change current, 7-5
web services
 retrieving ECG records, 8-11
 retrieving orders, 8-10
Welsh bulbs, 6-7
workflow, paperless, 1-4

FCC CONNECTION INFORMATION

The Atria internal socket modem complies with Part 68 of the FCC Rules. On the side of this equipment is a label that contains, among other information, the FCC Registration Number and ringer equivalence number (REN) for this equipment. If requested, this information must be provided to the telephone company.

The REN is used to determine the quantity of devices that may be connected to the telephone line. Excessive RENs on the telephone line may result in devices not ringing in response to an incoming call. In most, but not all areas, the sum of the RENs should not exceed five (5.0). To be certain of the number of devices that may be connected to the line, as determined by the total RENs, contact the telephone company to determine the total REN for the calling area.

If your Atria causes harm to the telephone network, the telephone company will notify you in advance that temporary discontinuance of service may be required. But if advance notice isn't practical, you will be notified as soon as possible. Also, you will be advised of your right to file a complaint with the FCC if you believe it is necessary.

The telephone company may make changes in its facilities, equipment, operations, or procedures that could effect the operation of the equipment. If this happens, the telephone company will provide advance notice in order for you to make the necessary modifications in order to maintain uninterrupted service.

If you experience trouble with your Atria, please contact Cardiac Science Corp. at (800) 777-1777 or (608) 764-1919 for repair/warranty information. If the trouble is causing harm to the telephone network, the telephone company may request you remove the equipment from the network until the problem is solved.

This equipment may not be used on coin service provided by the telephone company. Connection to Party Line Service is subject to state tariffs. (Contact the state public utility commission, public service commission, or corporation commission for information.)

This device is equipped with a USOC RJ11C connector

EQUIPMENT ATTACHMENT LIMITATIONS

NOTICE: The Atria internal socket modem has been certified by the Canadian Department of Communications. This certification means that the equipment meets certain telecommunications network protective, operational, and safety requirements. The Department does not guarantee the equipment will operate to the user's satisfaction.

Before installing this equipment, user's should ensure that it is permissible to be connected to the facilities of the local telecommunications company. The equipment must also be installed using an acceptable method of connection. In some cases, the company's inside wiring associated with a single-line individual service may be extended by means of a certified connector assembly (telephone extension cord). The customer should be aware that compliance with the above conditions may not prevent degradation of service in some situations.

Repairs to certified equipment should be made by an authorized Canadian maintenance facility designated by the supplier. Any repairs or alterations made by the user to this equipment, or equipment malfunctions, may give the telecommunications company cause to request the user to disconnect the equipment.

User's should ensure for their own protection that the electrical ground connections of the power utility, telephone lines, and internal metallic water pipe system, if present, are connected together. This precaution may be particularly important in rural areas.

CAUTION: Users should not attempt to make such connections themselves, but should contact the appropriate electric inspection authority, or electrician, as appropriate.

The LOAD NUMBER (5) assigned to each terminal device denotes the percentage of the total load to be connected to a telephone loop, which is used by the device to prevent overloading. The termination on a loop may consist of any combination of devices subject only to the requirement that the total of the Load Numbers of all of the devices does not exceed 100.

SERVICE STATION: If you have any questions or trouble, please contact Cardiac Science Corp. at (800) 777-1777 or (608) 764-1919.

Cardiac Science Corporation
3303 Monte Villa Parkway
Bothell, WA 98021, USA



Toll Free: +1.800.426.0337
Telephone: +1.425.402.2000
Website: www.cardiacscience.com
Email: techsupport@cardiacscience.com